

2-way and 3-way flow control valve type SD, SF, SK

Product documentation



Operating pressure p_{\max} :

315 bar

Flow rate Q_{\max} :

130 l/min



© by HAWE Hydraulik SE.

The reproduction and distribution of this document, as well as the use and communication of its contents to others without explicit authorization, is prohibited.

Offenders will be held liable for the payment of damages.

All rights reserved in the event of patent or utility model applications.

Brand names, product names and trademarks are not specifically indicated. In particular with regard to registered and protected names and trademarks, usage is subject to legal provisions.

HAWE Hydraulik respects these legal provisions in all cases.

HAWE Hydraulik cannot provide individual guarantees that the stated circuits or procedures (including in part) are not subject to the intellectual property rights of third parties.

Printing date / document generated on: 2024-04-09

Table of Contents

1	Overview of 2-way and 3-way flow control valve type SD, SF, SK.....	4
1.1	Overview of flow control valve type SD.....	5
1.2	Overview of flow control valve type SF.....	6
1.3	Overview of flow control valve type SK and SKR.....	7
2	Available versions.....	8
2.1	Flow control valve type SD with turning knob actuation.....	8
2.1.1	Basic type.....	8
2.1.2	Size.....	8
2.1.3	Flow rate range.....	9
2.1.4	Model and additional functions.....	10
2.2	Flow control valve type SF with adjusting screw.....	12
2.2.1	Basic type.....	12
2.2.2	Size.....	12
2.2.3	Flow rate range.....	13
2.2.4	Model and additional functions.....	14
2.3	Flow control valve type SK and SKR with roller actuation.....	16
2.3.1	Basic type.....	16
2.3.2	Size.....	16
2.3.3	Flow rate range.....	17
2.3.4	Model and additional functions.....	18
3	Parameters.....	20
3.1	General data.....	20
3.2	Pressure and volumetric flow.....	21
3.3	Weight.....	21
3.4	Characteristic lines.....	22
3.4.1	Setting characteristic lines.....	24
4	Dimensions.....	27
4.1	2-way flow control valve type SD, SF, SK and SKR.....	27
4.1.1	For pipe installation.....	27
4.1.2	For manifold mounting.....	31
4.2	3-way flow control valve type SD, SF, SK and SKR.....	32
4.2.1	For pipe installation.....	32
4.2.2	For manifold mounting.....	36
4.3	Actuations.....	38
4.3.1	Type SD.....	38
4.3.2	Type SF.....	38
4.3.3	Type SK.....	39
4.3.4	Type SKR.....	39
5	Installation, operation and maintenance information.....	40
5.1	Intended use.....	40
5.2	Assembly information.....	40
5.3	Operating instructions.....	40
5.4	Maintenance information.....	41
6	Other information.....	42
6.1	Structure and functional principle.....	42
6.2	Circuit examples.....	43

1 Overview of 2-way and 3-way flow control valve type SD, SF, SK

Flow control valves are a type of flow valve. They generate a set constant flow rate, largely independently of the load.

The flow control valve type SD, SF and SK can be freely adjusted with different mechanical actuations. The flow control valve type SD, SF and SK is available as a 2-way and 3-way flow control valve. For type SD, the adjustment is made using the adjusting knob; for type SF using the adjusting screw; and for type SK using the roller actuation. The flow control valve type SD, SF and SK is available as a single valve for pipe connection or as a manifold mounting valve.

Pressure-limiting valves and randomly switchable idle circulation valves are additional options. The flow control valve type SD, SF and SK controls the operating speed of the hydraulic consumers.

Features and advantages

- Various actuation types
- Optionally also available with additional valves (bypass check valve, pressure-limiting valve, idle circulation valve)
- Precise adjustment

Intended applications

- Construction machinery
- Machine tools
- General hydraulic systems



Flow control valve type SD, SF, SK

1.1 Overview of flow control valve type SD

see Chapter 2.1, "Flow control valve type SD with turning knob actuation"

Configuration example: **SD 3-3/50 S-315**

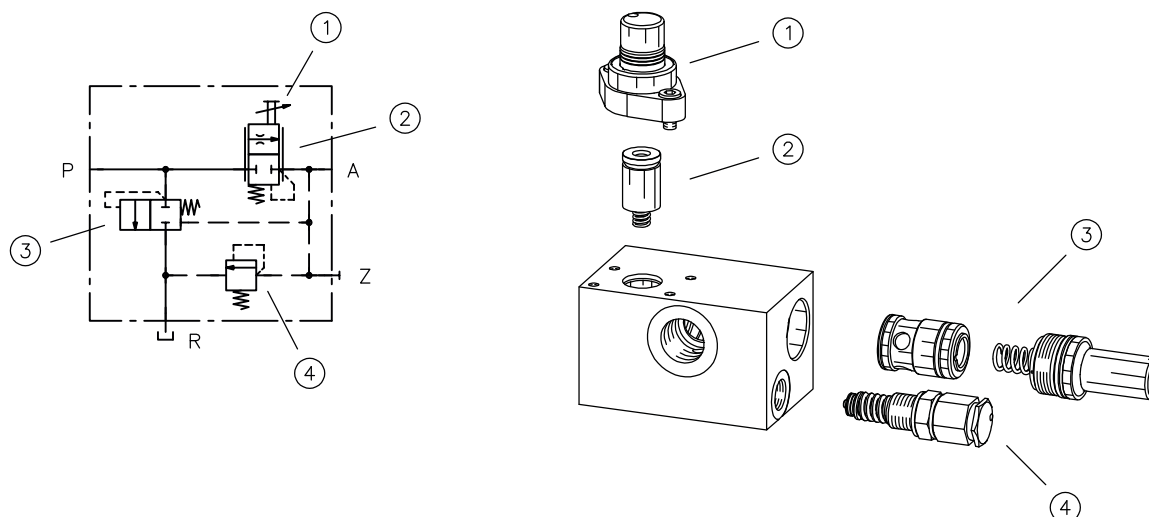

- 1 Turning knob to actuate the adjustment device see Chapter 2.1, "Flow control valve type SD with turning knob actuation"
- 2 Metering orifice: directly actuated, responsible for the consumer flow in port A and generates a slight pressure drop (measuring pressure) that is required for the control function of the pressure compensator see Chapter 2.1.3, "Flow rate range"
- 3 Pressure compensator: consists of a piston and a sleeve with bores and opens at approx. 5 bar to reduce the pressure at port P see Chapter 3.4, "Characteristic lines"
- 4 Optionally pressure-limiting valve as an additional valve to safeguard the inflow pressure. For other additional valves see Chapter 2.1.4, "Model and additional functions"

1.2 Overview of flow control valve type SF

see Chapter 2.2, "Flow control valve type SF with adjusting screw"

Configuration example: SF 3-3/50 S-315

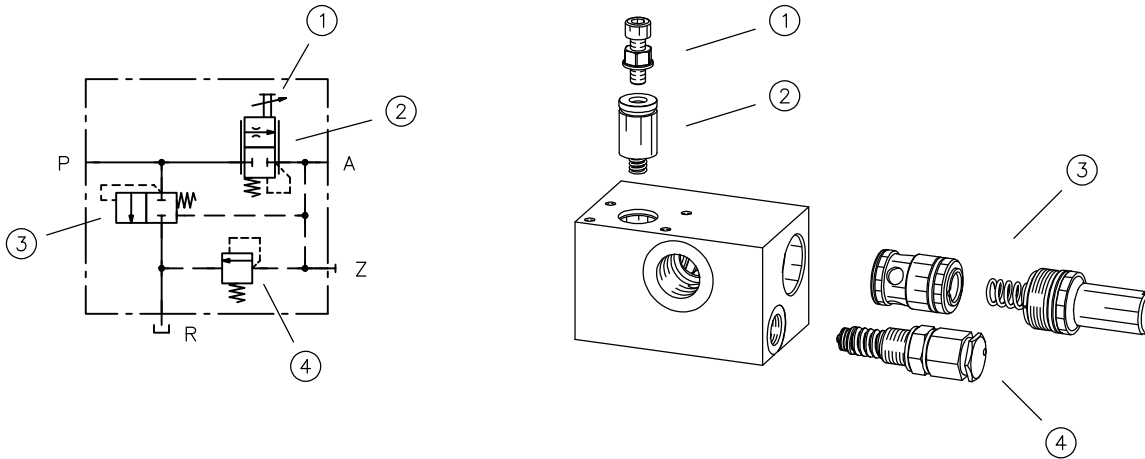

- 1 Lock nut with fixed setting: Adjusting screw to actuate the adjustment device
- 2 Metering orifice: directly actuated, responsible for the consumer flow in port A and generates a slight pressure drop (measuring pressure) that is required for the control function of the pressure compensator [see Chapter 2.2.3, "Flow rate range"](#)
- 3 Pressure compensator: consists of a piston and a sleeve with bores and opens at approx. 5 bar to reduce the pressure at port P [see Chapter 3.4, "Characteristic lines"](#)
- 4 Optionally pressure-limiting valve as an additional valve to safeguard the inflow pressure. For other additional valves [see Chapter 2.2.4, "Model and additional functions"](#)

1.3 Overview of flow control valve type SK and SKR

see Chapter 2.3, "Flow control valve type SK and SKR with roller actuation"

Configuration example: **SK 3-3/50 S-315**

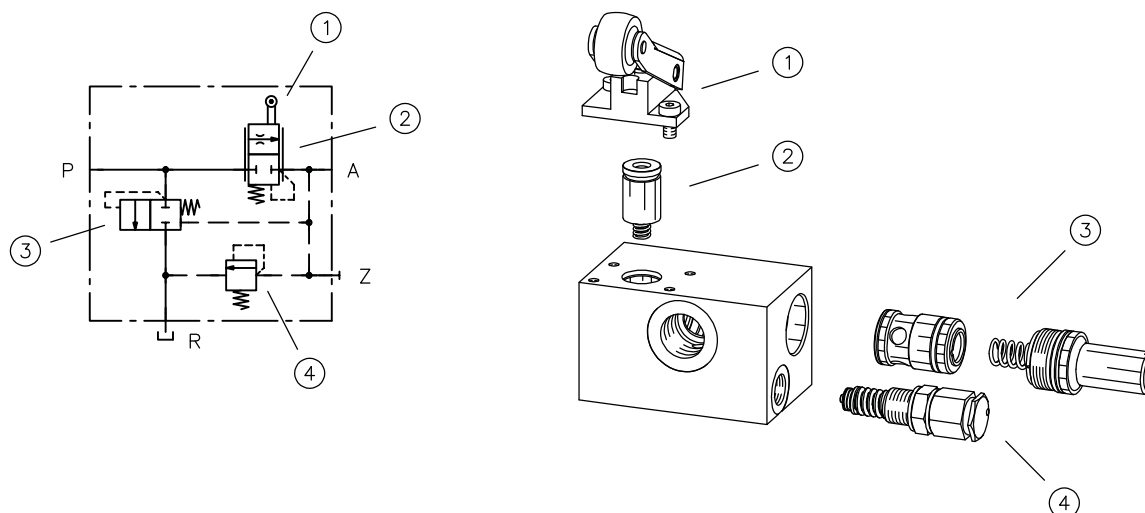

- 1 Adjustment device controlled by actuating the roller see Chapter 2.1, "Flow control valve type SD with turning knob actuation"
- 2 Metering orifice: directly actuated, responsible for the consumer flow in port A and generates a slight pressure drop (measuring pressure) that is required for the control function of the pressure compensator see Chapter 2.3.3, "Flow rate range"
- 3 Pressure compensator: consists of a piston and a sleeve with bores and opens at approx. 5 bar to reduce the pressure at port P see Chapter 3.4, "Characteristic lines"
- 4 Optionally pressure-limiting valve as an additional valve to safeguard the inflow pressure. For other additional valves see Chapter 2.3.4, "Model and additional functions"

2 Available versions

2.1 Flow control valve type SD with turning knob actuation

Ordering example

SD 2	-3	/6	P
			2.1.4 "Model and additional functions"
			2.1.3 "Flow rate range"
			2.1.2 "Size"
			2.1.1 "Basic type"

2.1.1 Basic type

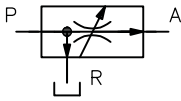
Type	Description	Circuit symbol
SD 2	2-way flow control valve	
SD 3	3-way flow control valve	

2.1.2 Size

Type	Size	Flow rate Q_{\max} (l/min)	Pressure p_{\max} (bar)		Ports (ISO 228-1) P, R, A	
			Pipe connection	Manifold mounting	Pipe connections	Manifold mounting
SD 2 SD 3	3	60	315	315	G 1/2	*
SD 2 SD 3	4	90	315	315	G 3/4	*
SD 2 SD 3	5	130	315	315	G 1	*

* For the ports for the flow valve for manifold mounting "3-way flow control valve type SD, SF, SK and SKR"

2.1.3 Flow rate range

i INFORMATION

The flow rate at port P must always be greater than the set flow rate in order to ensure the internal drop in pilot pressure for moving the pressure compensator.

Metering orifice, normally open when

Type	Coding	Flow rate Q (l/min)
SD 2-3	3	0.1 to 3
SD 3-3	6	0.3 to 6
	15	0.3 to 15
	30	0.3 to 30
	26	0.3 to 36
	50	0.3 to 50
	60	0.3 to 60
SD 2-4	70	0.3 to 70
SD 3-4	90	0.3 to 90
SD 2-5	130	1 to 130
SD 3-5		

Metering orifice, normally closed when

Type	Coding	Flow rate Q (l/min)
SD 2-3	6 F	0.3 to 6
SD 3-3	15 F	0.3 to 15
	30 F	0.3 to 30
	36 F	0.3 to 36
	50 F	0.3 to 50

2.1.4 Model and additional functions

For pipe connection

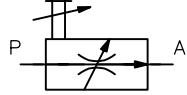
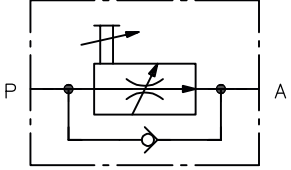
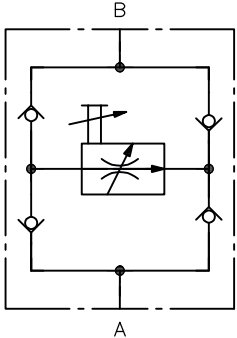
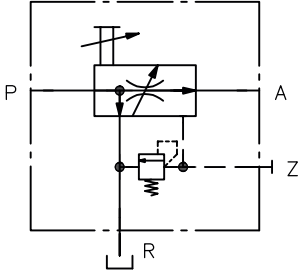
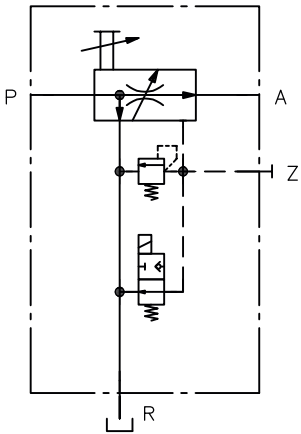
Type	Coding	Description	Circuit symbol
SD 2-3 SD 2-4 SD 2-5 SD 3-3 SD 3-4 SD 3-5	without coding	Standard version without additional function Ordering example: SD 2-3/15	
SD 2-3 SD 2-4 SD 2-5	R	Version with bypass check valve for free return flow A → P Ordering example: SD 2-3/50 R	
SD 2-3	B	Version with check valve bridge rectifier Flow rate control in both flow directions Ordering example: SD 2-3/50 B	
SD 3-3 SD 3-4 SD 3-5	S	Version with pressure-limiting valve Pressure setting in bar. Adjustment range depending on spring see Chapter 4, "Dimensions" <ul style="list-style-type: none"> 10 to 200 bar 200 to 315 bar Ordering example: SD 3-3/50 S-315	
SD 3-3 SD 3-4 SD 3-5	S-WN 1 F S-WN 1 D	Version with pressure-limiting valve and idle circulation valve (for directional seated valve see D 7470 A/1) <ul style="list-style-type: none"> WN 1 F: open when de-energised (see circuit symbol) WN 1 D: closed when de-energised <div style="border: 1px solid black; padding: 5px; margin: 10px 0;"> <p>i INFORMATION Idle circulation valve $p_{min} = 6$ to 10 bar</p> </div> Pressure setting of pressure-limiting valve in bar. Adjustment range depending on spring see Chapter 4, "Dimensions" <ul style="list-style-type: none"> 10 to 200 bar 200 to 315 bar Ordering example: SD 3-3/50 S-WN 1 F-G 24-200	

For manifold mounting

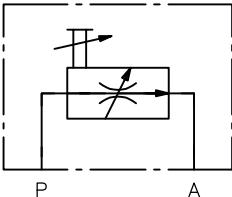
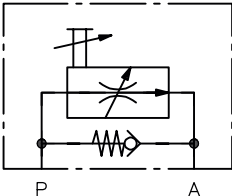
Type	Coding	Description	Circuit symbol
SD 2-3 SD 2-4 SD 2-5 SD 3-3 SD 3-4 SD 3-5	P	Standard version without additional function Ordering example: SD 2-3/6 P	
SD 2-3 SD 2-4 SD 2-5	PR	Version with bypass check valve for free return flow A → P Ordering example: SD 2-3/6 PR	

2.2 Flow control valve type SF with adjusting screw

Ordering example

SF 3-3/30 P-230

SF 3	-3	/30	P
			2.2.4 "Model and additional functions"
			2.2.3 "Flow rate range"
			2.2.2 "Size"
			2.2.1 "Basic type"

2.2.1 Basic type

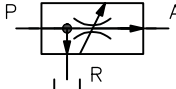
Type	Description	Circuit symbol
SF 2	2-way flow control valve	
SF 3	3-way flow control valve	

2.2.2 Size

Type	Size	Flow rate Q_{max} (l/min)	Pressure p_{max} (bar)		Ports (ISO 228-1) P, R, A	
			Pipe connection	Manifold mounting	Pipe connections	Manifold mounting
SF 2 SF 3	3	60	315	315	G 1/2	*
SF 2 SF 3	4	90	315	315	G 3/4	*
SF 2 SF 3	5	130	315	315	G 1	*

* For the ports for the flow valve for manifold mounting "3-way flow control valve type SD, SF, SK and SKR"

2.2.3 Flow rate range

i INFORMATION

The flow rate at port P must always be greater than the set flow rate in order to ensure the internal drop in pilot pressure for moving the pressure compensator.

Metering orifice, normally open when

Type	Coding	Flow rate Q (l/min)
SF 2-3	3	0.1 to 3
SF 3-3	6	0.3 to 6
	15	0.3 to 15
	30	0.3 to 30
	26	0.3 to 36
	50	0.3 to 50
	60	0.3 to 60
SF 2-4	70	0.3 to 70
SF 3-4	90	0.3 to 90
SF 2-5	130	1 to 130
SF 3-5		

Metering orifice, normally closed when

Type	Coding	Flow rate Q (l/min)
SF 2-3	6 F	0.3 to 6
SF 3-3	15 F	0.3 to 15
	30 F	0.3 to 30
	36 F	0.3 to 36
	50 F	0.3 to 50

2.2.4 Model and additional functions

For pipe connection

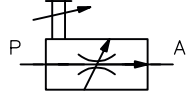
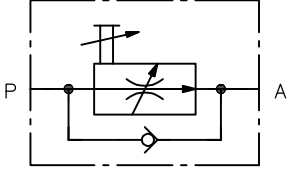
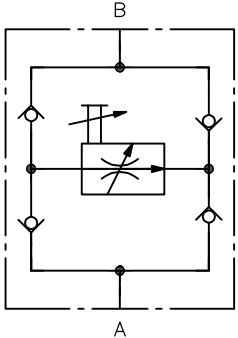
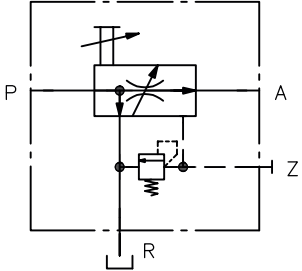
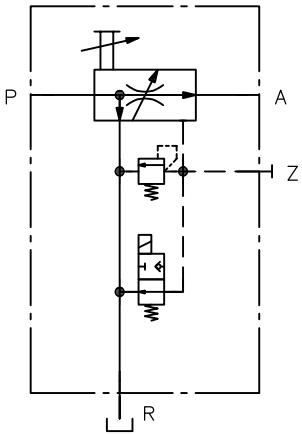
Type	Coding	Description	Circuit symbol
SF 2-3 SF 2-4 SF 2-5 SF 3-3 SF 3-4 SF 3-5	without coding	Standard version without additional function Ordering example: SF 3-4/90	
SF 2-3 SF 2-4 SF 2-5	R	Version with bypass check valve for free return flow A → P Ordering example: SD 2-3/50 R	
SF 2-3	B	Version with check valve bridge rectifier Flow rate control in both flow directions Ordering example: SF 2-3/50 B	
SF 3-3 SF 3-4 SF 3-5	S	Version with pressure-limiting valve Pressure setting in bar. Adjustment range depending on spring see Chapter 4, "Dimensions" <ul style="list-style-type: none"> 10 to 200 bar 200 to 315 bar Ordering example: SF 3-4/90 S-250	
SF 3-3 SF 3-4 SF 3-5	S-WN 1 F S-WN 1 D	Version with pressure-limiting valve and idle circulation valve (directional seated valve according to D 7470 A/1) <ul style="list-style-type: none"> WN 1 F: open when de-energised (see circuit symbol) WN 1 D: closed when de-energised <div style="border: 1px solid gray; padding: 5px; margin: 10px 0;"> <p>i INFORMATION Idle circulation valve $p_{min} = 6$ to 10 bar</p> </div> Pressure setting of pressure-limiting valve in bar. Adjustment range depending on spring see Chapter 4, "Dimensions" <ul style="list-style-type: none"> 10 to 200 bar 200 to 315 bar Ordering example: SF 3-3/30 S-WN 1 D-G 24-120	

For manifold mounting

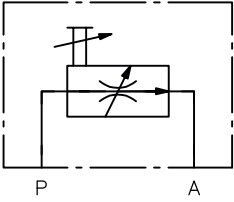
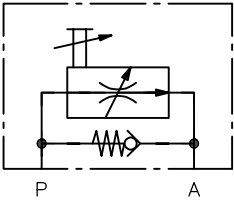
Type	Coding	Description	Circuit symbol
SF 2-3 SF 2-4 SF 2-5 SF 3-3 SF 3-4 SF 3-5	P	Standard version without additional function Ordering example: SF 3-3/30 P	
SF 2-3 SF 2-4 SF 2-5	PR	Version with bypass check valve for free return flow A → P Ordering example: SF 2-3/6 PR	

2.3 Flow control valve type SK and SKR with roller actuation

Ordering example

SK 2-4/90 R-230

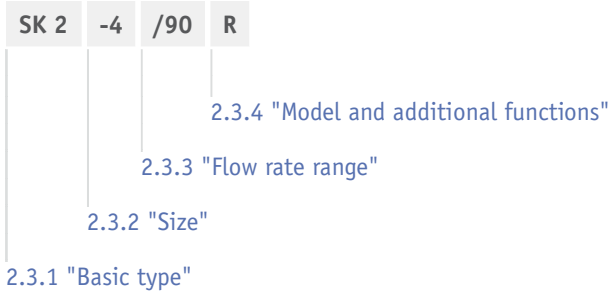

2.3.1 Basic type

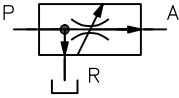
Type	Description	Circuit symbol
SK 2 SKR 2	2-way flow control valve <ul style="list-style-type: none"> SK: open version SKR: closed version – only in combination with pipe connections see Chapter 2.3.4, "Model and additional functions" 	
SK 3 SKR	3-way flow control valve <ul style="list-style-type: none"> SK: open version SKR: closed version – only in combination with pipe connections see Chapter 2.3.4, "Model and additional functions" 	

2.3.2 Size

Type	Size	Flow rate Q_{max} (l/min)	Pressure p_{max} (bar)		Ports (ISO 228-1) P, R, A	
			Pipe connection	Manifold mounting	Pipe connections	Manifold mounting
SK 2, SKR 2 SK 3, SKR 3	3	60	315	315	G 1/2	*
SK 2, SKR 2 SK 3, SKR 3	4	90	315	315	G 3/4	*
SK 2, SKR 2 SK 3, SKR 3	5	130	315	315	G 1	*

* Ports for the flow valve for manifold mounting "3-way flow control valve type SD, SF, SK and SKR"

2.3.3 Flow rate range

i INFORMATION

The flow rate at port P must always be greater than the set flow rate in order to ensure the internal drop in pilot pressure for moving the pressure compensator.

Metering orifice, normally open

Type	Coding	Flow rate Q (l/min)
SK 2-3	3	0.1 to 3
SKR 2-3	6	0.3 to 6
SK 3-3	15	0.3 to 15
SKR 3-3	30	0.3 to 30
	26	0.3 to 36
	50	0.3 to 50
	60	0.3 to 60
SK 2-4	70	0.3 to 70
SKR 2-4	90	0.3 to 90
SK 3-4		
SKR 3-4		
SK 2-5	130	1 to 130
SKR 2-5		
SK 3-5		
SKR 3-5		

Metering orifice, normally closed

Type	Coding	Flow rate Q (l/min)
SK 2-3	6 F	0.3 to 6
SK 3-3	15 F	0.3 to 15
	30 F	0.3 to 30
	36 F	0.3 to 36
	50 F	0.3 to 50

2.3.4 Model and additional functions

For pipe connection

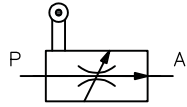
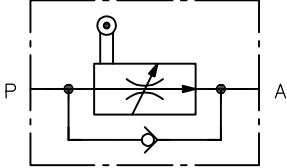
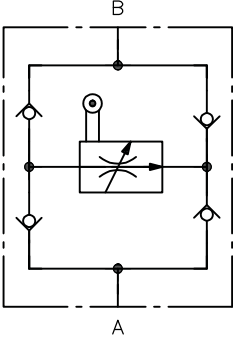
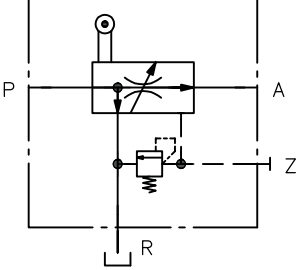
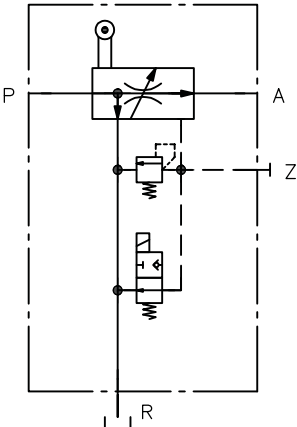
Type	Coding	Description	Circuit symbol
SK 2-3, SKR 2-3 SK 2-4, SKR 2-4 SK 2-5, SKR 2-5 SK 3-3, SKR 3-3 SK 3-4, SKR 3-4 SK 3-5, SKR 3-5	without coding	Standard version without additional function Ordering example: SK 2-3/50	
SK 2-3, SKR 2-3 SK 2-4, SKR 2-4 SK 2-5, SKR 2-5	R	Version with bypass check valve for unhindered return flow A → P Ordering example: SK 2-4/90 R	
SK 2-3, SKR 2-3	B	Version with check valve bridge rectifier Flow rate control in both flow directions Ordering example: SK 2-3/6 B	
SK 3-3, SKR 3-3 SK 3-4, SKR 3-4 SK 3-5, SKR 3-5	S	Version with pressure-limiting valve Pressure setting in bar. Adjustment range depending on spring see Chapter 4, "Dimensions" <ul style="list-style-type: none"> 10 to 200 bar 200 to 315 bar Ordering example: SK 3-4/70 S-290	
SK 3-3, SKR 3-3 SK 3-4, SKR 3-4 SK 3-5, SKR 3-5	S-WN 1 F S-WN 1 D	Version with pressure-limiting valve and idle circulation valve (directional seated valve according to D 7470 A/1) <ul style="list-style-type: none"> WN 1 F: open when de-energised (see circuit symbol) WN 1 D: closed when de-energised <div style="border: 1px solid black; padding: 5px; margin: 10px 0;"> <p>NOTICE Idle circulation valve $p_{min} = 6$ to 10 bar</p> </div> Pressure setting of pressure-limiting valve in bar. Adjustment range depending on spring see Chapter 4, "Dimensions" <ul style="list-style-type: none"> 10 to 200 bar 200 to 315 bar Ordering example: SK 3-3/50 S-WN 1 F-G 24-200	

For manifold mounting

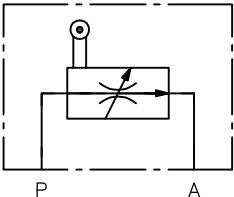
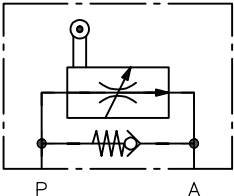
Type	Coding	Description	Circuit symbol
SK 2-3 SK 2-4 SK 2-5 SK 3-3 SK 3-4 SK 3-5	P	Standard version without additional function Ordering example: SK 2-3/50 P	
SK 2-3 SK 2-4 SK 2-5	PR	Version with bypass check valve for unhindered return flow A → P SK 2-3/15 PR	

3.1 General data

Designation	2-way and 3-way flow control valve
Design	Flow control valve
Model	<ul style="list-style-type: none"> ▪ Single valve for pipe connection ▪ Manifold mounting valve
Material	Valve block: steel, nitrided surface
Attachment	Mounting thread or tapped holes, see Chapter 4, "Dimensions"
Installation position	any
Ports/connections	<ul style="list-style-type: none"> ▪ P = Pump ▪ R = Reflux ▪ A = Consumer outlet ▪ Z = external control port <p>Connecting thread: SD: see Chapter 2.1.2, "Size" SF: see Chapter 2.2.2, "Size" SK: see Chapter 2.3.2, "Size"</p>
Flow direction	<p>Operating direction:</p> <ul style="list-style-type: none"> ▪ P → A and P → R ▪ A → B or B → A for the version with a bridge rectifier (S... 2-3/...B) <p>Opposite direction:</p> <ul style="list-style-type: none"> ▪ A → P only with bypass check valve
Hydraulic fluid	<p>Hydraulic fluid, according to DIN 51 524 Parts 1 to 3; ISO VG 10 to 68 according to DIN ISO 3448</p> <p>Viscosity range: 4 - 1500 mm²/s</p> <p>Optimal operating range: approx. 10 - 500 mm²/s</p> <p>Also suitable for biologically degradable hydraulic fluids type HEPG (polyalkylene glycol) and HEES (synthetic ester) at operating temperatures up to approx. +70°C.</p>
Cleanliness level	<p>ISO 4406</p> <hr style="width: 20%; margin-left: 0;"/> <p>20/17/14</p>
Temperatures	<p>Environment: approx. -40 to +80 °C, hydraulic fluid: -25 to +80 °C, pay attention to the viscosity range.</p> <p>Start temperature: down to -40 °C is permissible (take account of the start viscosities!), as long as the steady-state temperature is at least 20 K higher during subsequent operation.</p> <p>Biologically degradable hydraulic fluids: note manufacturer specifications. With consideration for the seal compatibility, not above +70°C.</p>

3.2 Pressure and volumetric flow

Operating pressure	Ports P, A, Z, R: $p_{max} = 315$ bar
	<p>! NOTICE</p> <p>In the case of a 3-way flow control valve, the permissible counter-pressure at port R must always be lower than the prevailing consumer pressure at port A (minimum difference: 8 bar).</p>
Flow rate	<p>SD: Q_{max} see Chapter 2.1.1, "Basic type"</p> <p>SF: Q_{max} see Chapter 2.2.1, "Basic type"</p> <p>SK, SKR: Q_{max} see Chapter 2.3.1, "Basic type"</p>
Pressure setting	<p>100 bar if no other value is specified in the order.</p> <p>The pressure setting is the operating pressure at which the set flow rate is set see Chapter 3.4, "Characteristic lines"</p>

3.3 Weight

Type	Size		
	3	4	5
SD 2-... SD 3-...	1.4 kg	2.1 kg	2.0 kg
SF 2-... SF 3-...	1.4 kg	2.1 kg	2.0 kg
SK 2-..., SKR 2-... SK 3-..., SKR 3-...	1.4 kg	2.1 kg	2.0 kg
SD 3-...-WN 1...	2.0 kg	2.7 kg	3.7 kg
SF 3-...-WN 1...	2.0 kg	2.7 kg	3.7 kg
SK 3-...-WN 1... SKR 3-...-WN 1...	2.0 kg	2.7 kg	3.7 kg

3.4 Characteristic lines

Viscosity of the hydraulic fluid approx. 35 mm²/s

p-Q characteristic line for 2-way and 3-way flow control valve

2-way flow control valve

S.. 2-3

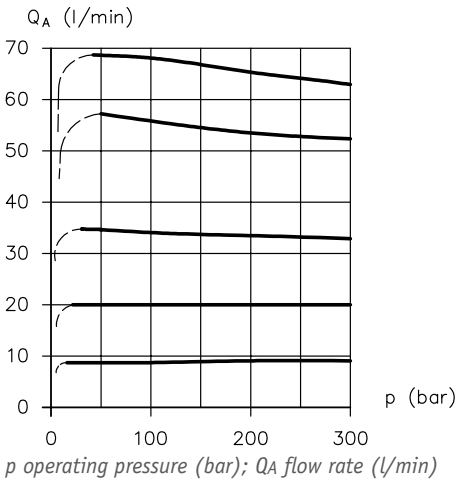

S.. 2-4

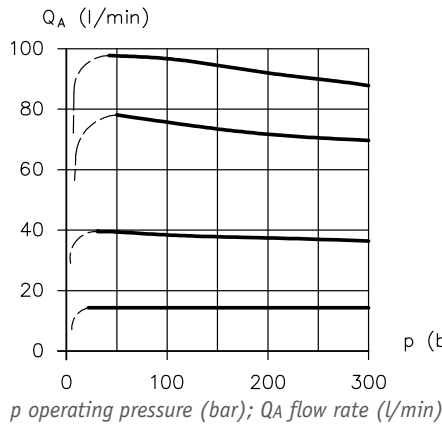

S.. 2-5

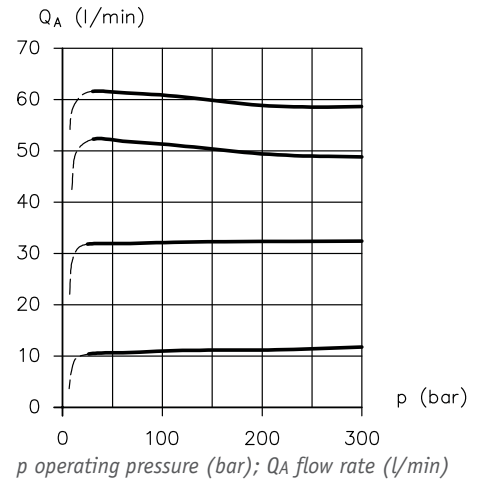

3-way flow control valve

S.. 3-3

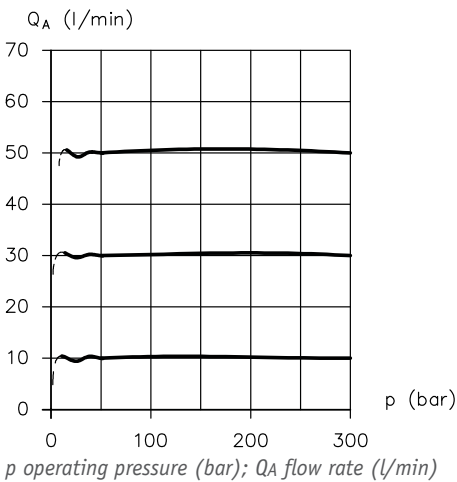

S.. 3-4

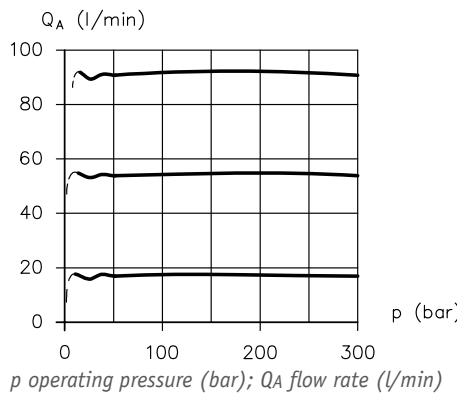

S.. 3-5

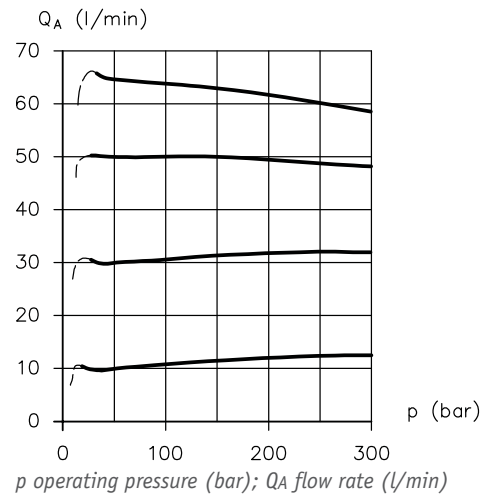

Δp-Q characteristic line for 2-way flow control valve with bypass check valve

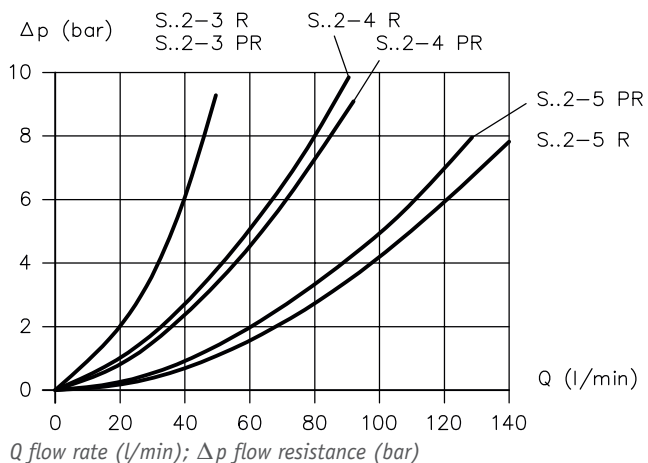

Circulation resistance when load on pressure compensator has been relieved

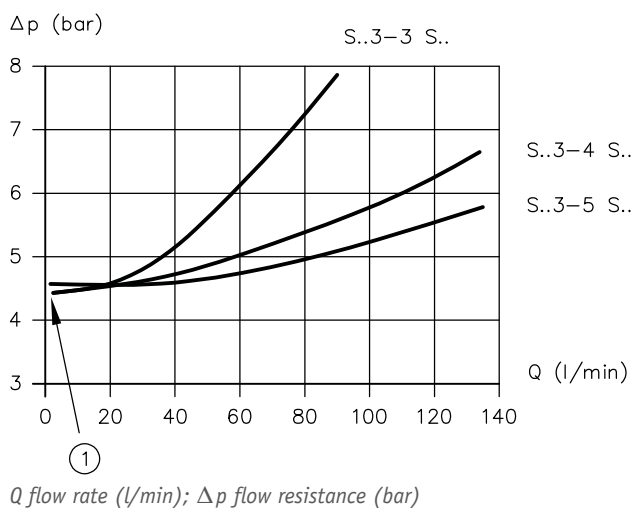

1 Opening pressure

3.4.1 Setting characteristic lines

Type SD

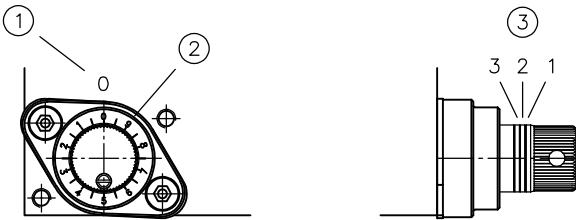
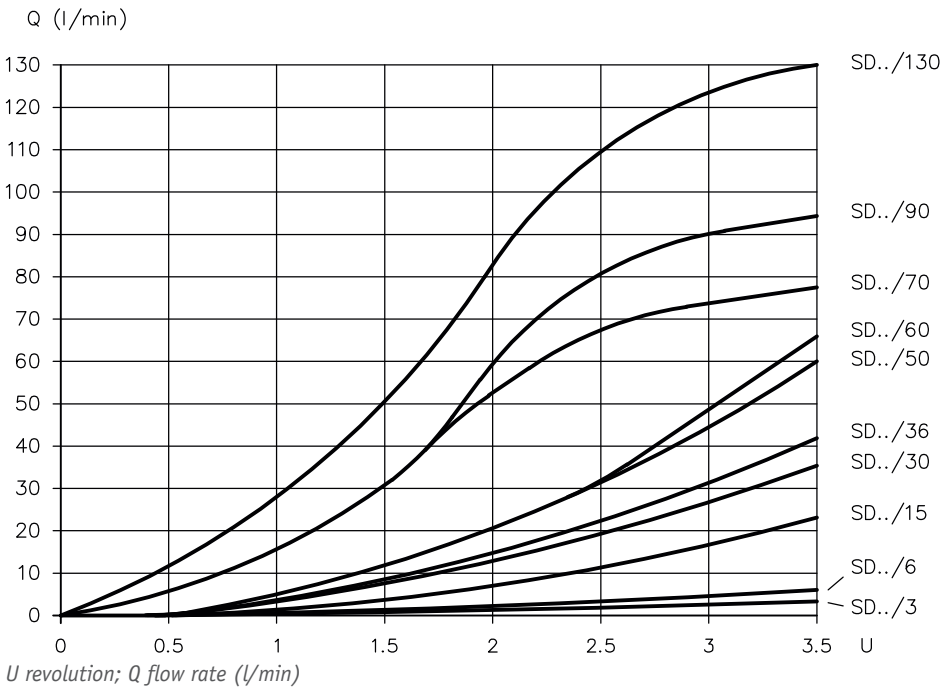

- 1 Notch to mark the 0 position
- 2 Scale graduation for one revolution
- 3 Revolution

Type SF

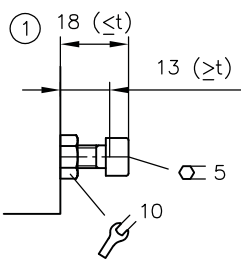
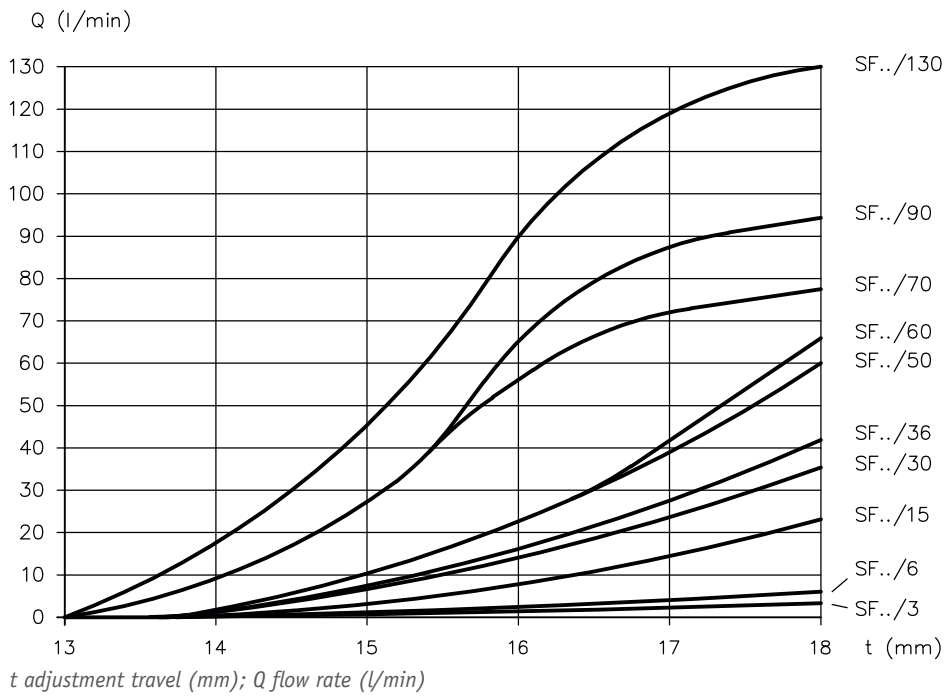

1 Adjustment travel

Type SK, SKR

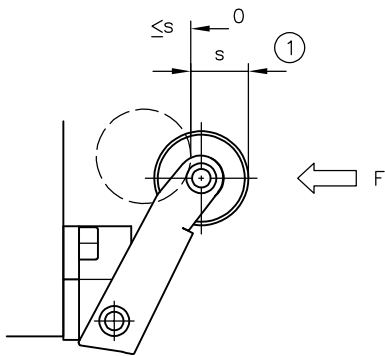
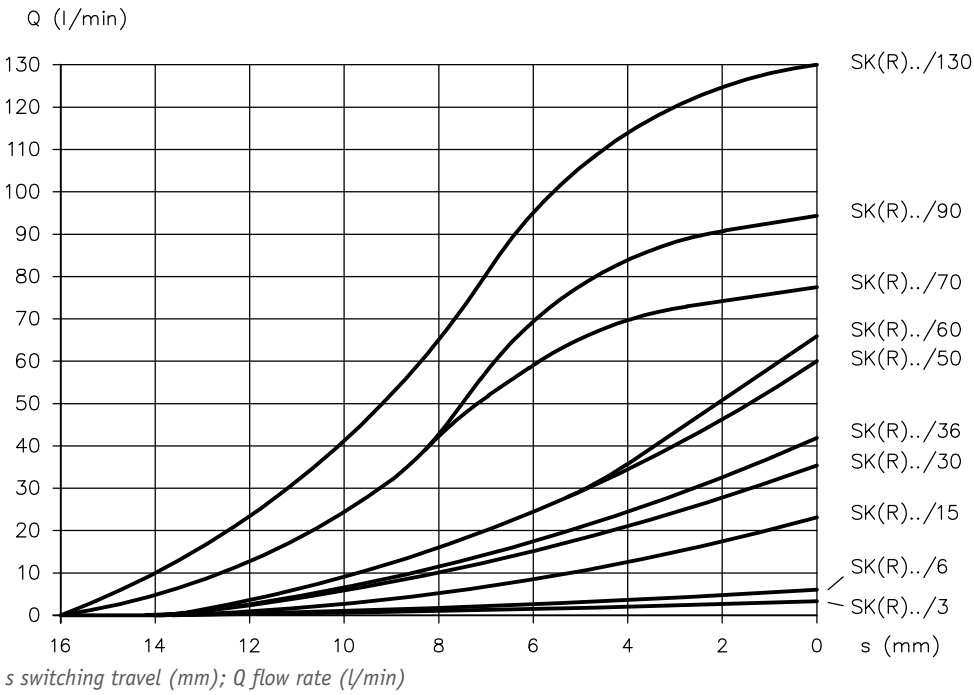

1 Switching travel

Actuation force F (reference values) at

- 0 bar ... approx. 30 N
- 100 bar ... approx. 44 N
- 200 bar ... approx. 56 N
- 300 bar ... approx. 70 N

4 Dimensions

All dimensions in mm, subject to change.

4.1 2-way flow control valve type SD, SF, SK and SKR

4.1.1 For pipe installation

Standard version without additional function

S.. 2-3

S.. 2-4

S.. 2-5

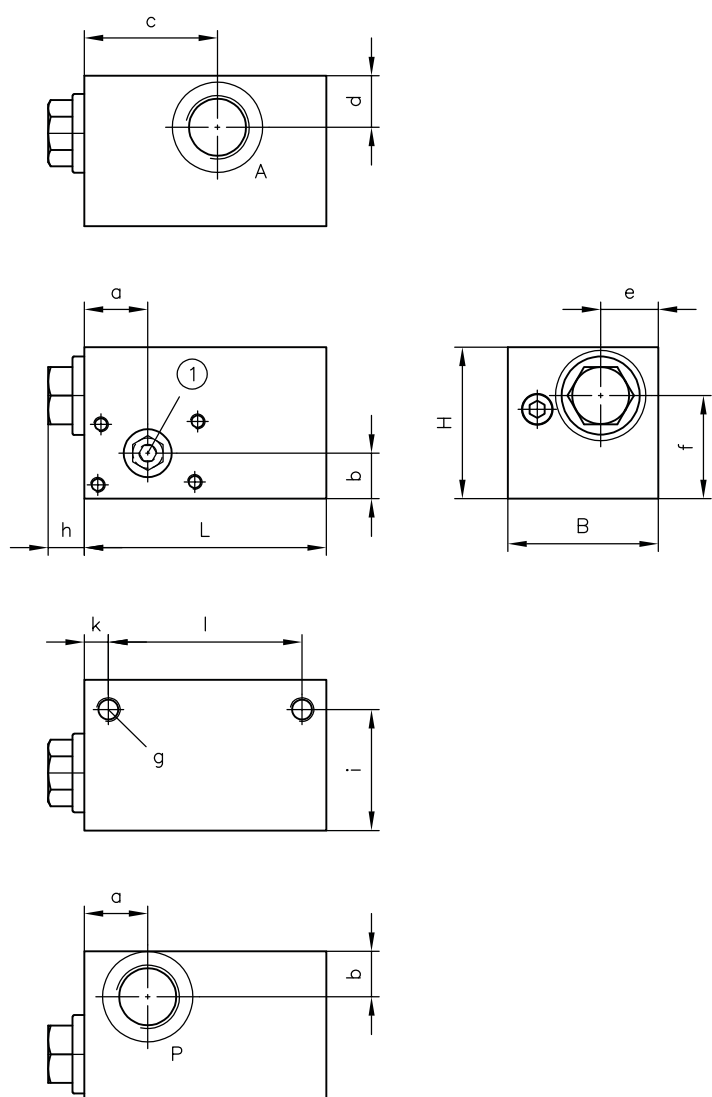

1 see Chapter 4.3, "Actuations"

Size	L	B	H	a	b	c	d	e	f	h	i	k	l
3	80	50	50	21	15	44	17	19	34	12	40	8	64
4	85	60	60	25	19	53	21	21	41	14	48	10	65
5	100	70	70	27	24	60	23	23	47	16	52	20	60

Size	Ports (ISO 228-1)
	A, P
3	G 1/2
4	G 3/4
5	G 1

Version with bypass check valve coding R

S.. 2-3 R

S.. 2-4 R

S.. 2-5 R

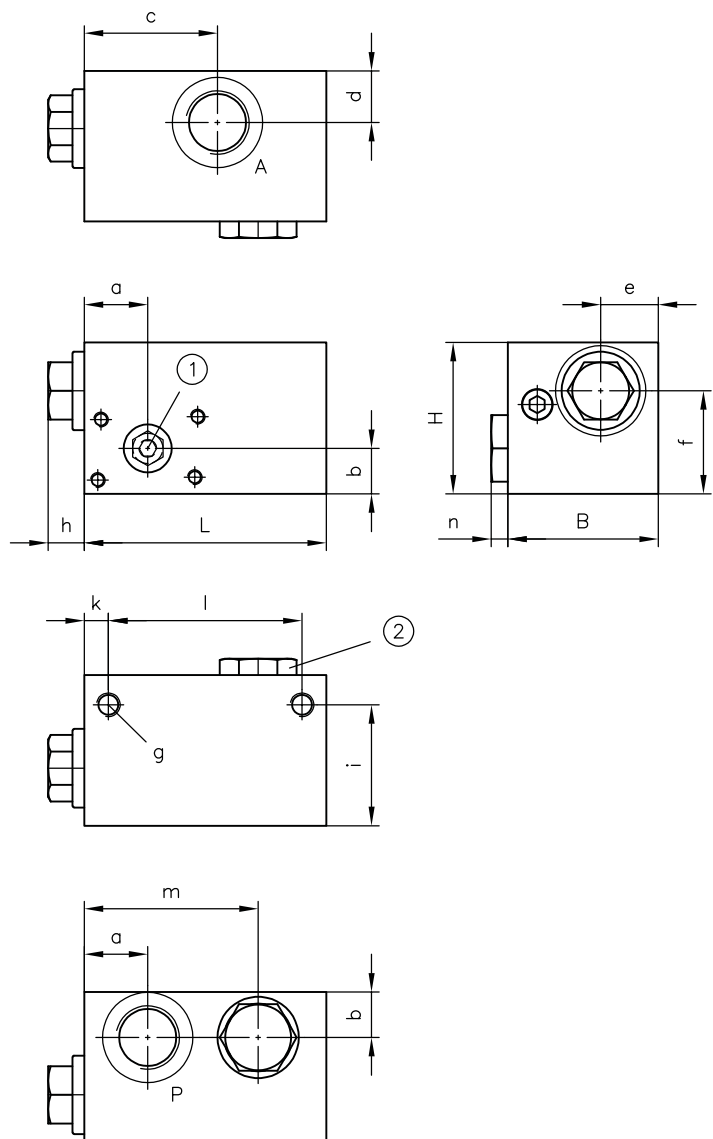

1 see Chapter 4.3, "Actuations"

2 Check valve

Size	L	B	H	a	b	c	d	e	f	g	h	i	k
3	80	50	50	21	15	44	17	19	34	M8, 8 deep	12	40	8
4	85	60	60	25	19	53	21	21	41	M8, 10 deep	14	48	10
5	100	70	70	27	24	60	23	23	47	M10, 12 deep	16	52	20

Size	l	m	n	Ports (ISO 228-1)
				A, P
3	64	57	5.5	G 1/2
4	65	68	5.5	G 3/4
5	60	80	11	G 1

Version with check valve bridge rectifier coding B

S.. 2-3 B

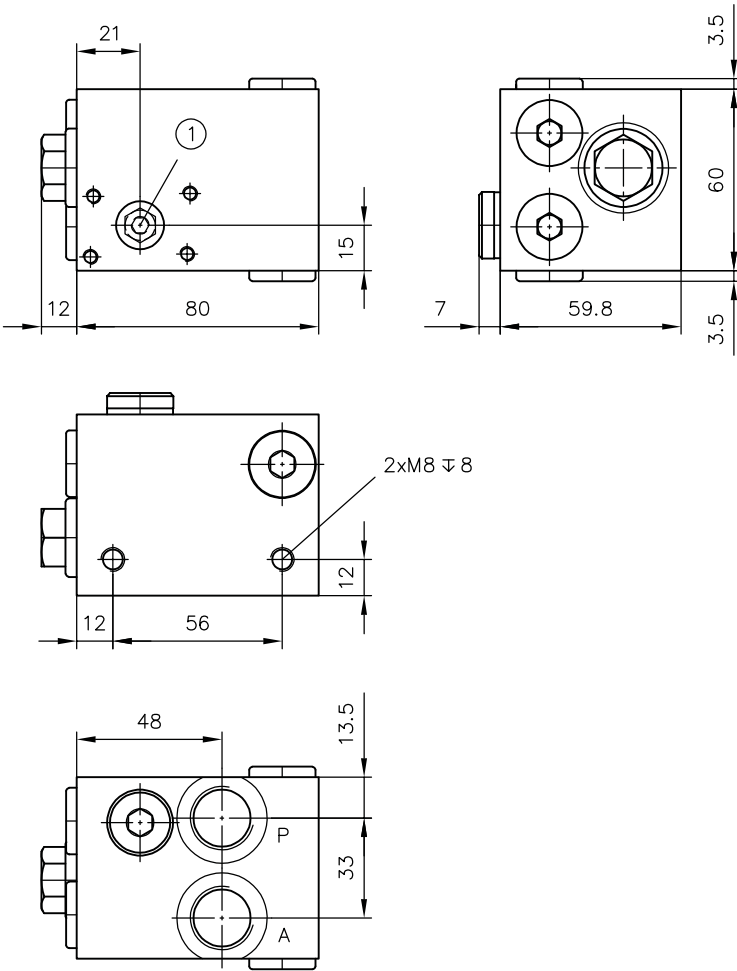

1 see Chapter 4.3, "Actuations"

4.1.2 For manifold mounting

Standard version coding P without additional functions and version with bypass check valve coding PR

S.. 2-3 P, S.. 2-3 PR

S.. 2-4 P, S.. 2-4 PR

S.. 2-5 P, S.. 2-5 PR

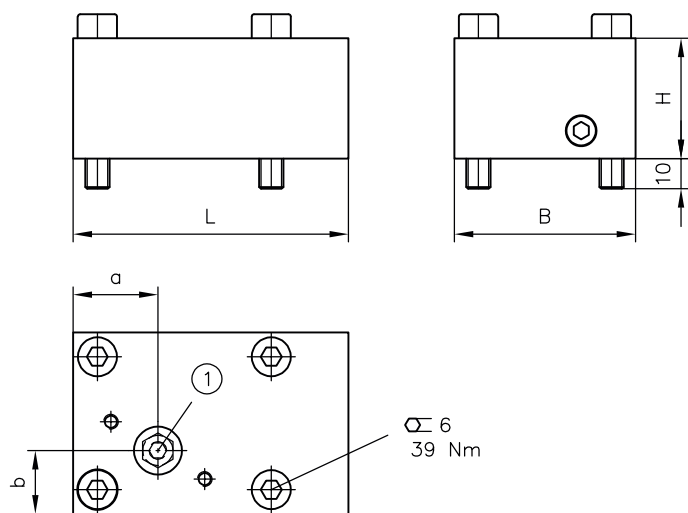

1 see Chapter 4.3, "Actuations"

Size	L	B	H	a	b
3	93	60	40	28	21
4	97	70	49.75	35	26
5	106	80	49.8	33	28

Hole pattern of the base plate

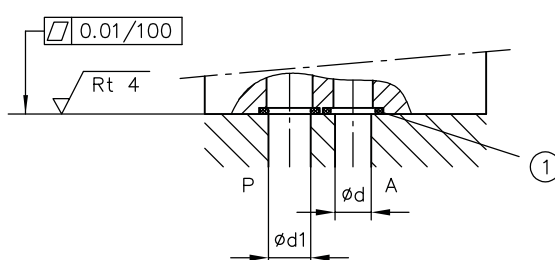
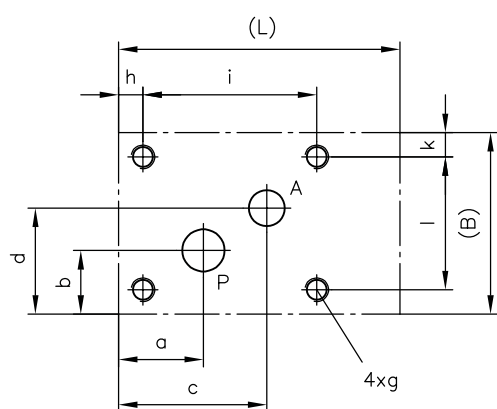

1 O-ring

Size	L	B	a	b	c	d	h	i	k	l	g	Ød	Ød1
3	93	60	28	21	49	35	8	57.5	8	44	M8, 10 deep	12	14
4	97	70	35	26	57	42	16	57	9	52	M10, 10 deep	17	17
5	106	80	33	28	65	48	9	88	8	64	M10, 10 deep	17	17

Size	O-ring NBR 90 Sh	
	A	P
3	15x2.5	15x2.5
4	18.75x2.62	18.75x2.62
5	18.75x2.62	26x3

4.2 3-way flow control valve type SD, SF, SK and SKR

4.2.1 For pipe installation

Standard version without additional functions

S.. 3-3, S.. 3-4, S.. 3-5

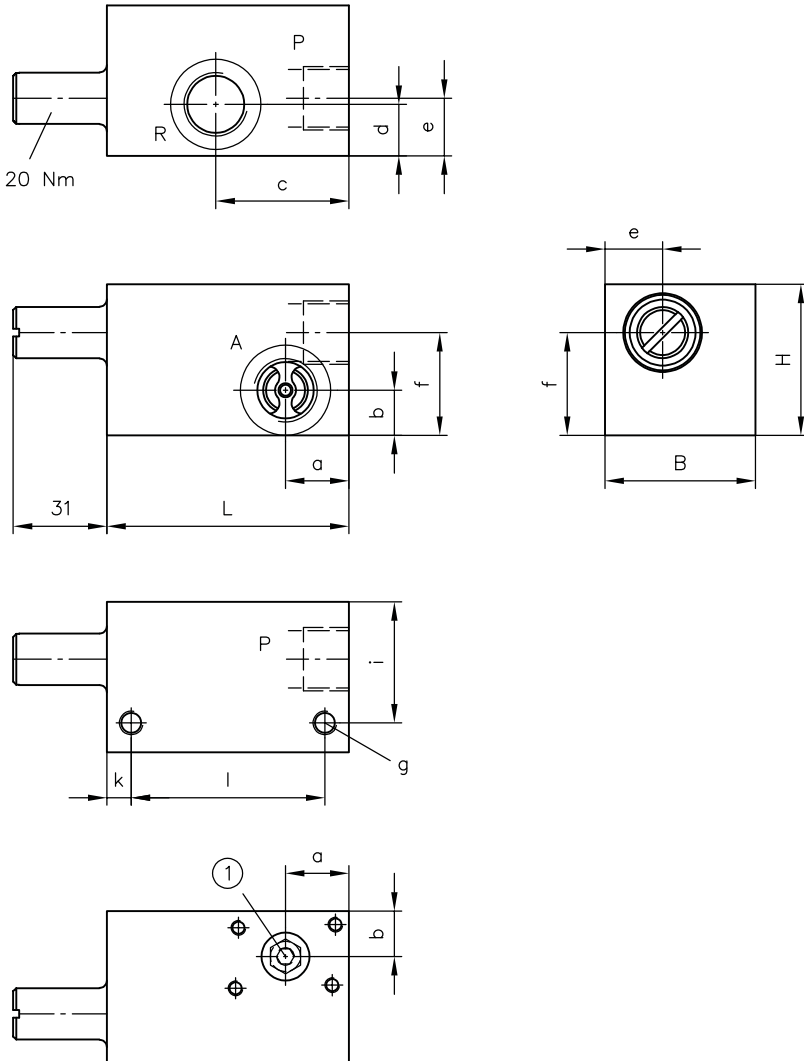

1 see Chapter 4.3, "Actuations"

Size	L	B	H	a	b	c	d	e	f	g	i	k	l
3	80	50	50	21	15	44	17	19	34	M8, 8 deep	40	8	64
4	85	60	60	25	19	53	21	21	41	M8, 10 deep	48	10	65
5	100	70	70	27	24	60	23	23	47	M10, 12 deep	52	20	60

Size	Ports (ISO 228-1)
	A, P, R
3	G 1/2
4	G 3/4
5	G 1

Version with pressure-limiting valve coding S

S.. 3-3 S, S.. 3-4 S, S.. 3-5 S

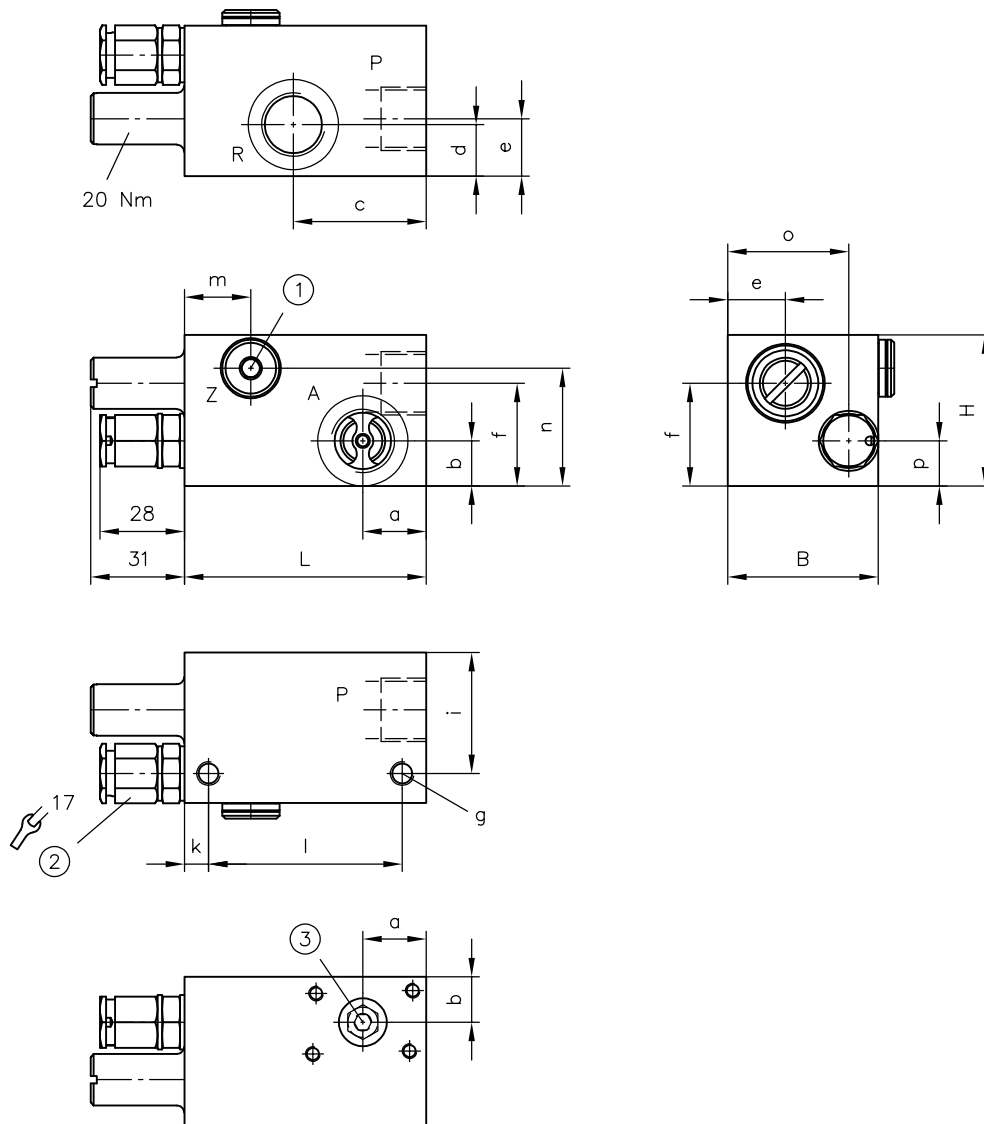

- 1 Pilot control port Z: only in conjunction with a pressure-limiting valve
- 2 Pressure-limiting valve for the version with coding S
- 3 see Chapter 4.3, "Actuations"

Size	L	B	H	a	b	c	d	e	f	g	i	k	l
3	80	50	50	21	15	44	17	19	34	M8, 8 deep	40	8	64
4	85	60	60	25	19	53	21	21	41	M8, 10 deep	48	10	65
5	100	70	70	27	24	60	23	23	47	M10, 12 deep	52	20	60

Size	m	n	o	p	Ports (ISO 228-1)
					A, P, R
3	22	39	40	15	G 1/2
4	30	41	46	23	G 3/4
5	30	47	54.7	24	G 1

Pressure setting range (bar)	Travel f_{max} (mm)	Δp (bar) per revolution
10 to 200	4	90
200 to 315	4	150

Version with pressure-limiting valve and idle circulation valve coding S-WN 1..

S.. 3-3 S-WN 1 F(D)

S.. 3-4 S-WN 1 F(D)

S.. 3-5 S-WN 1 F(D)

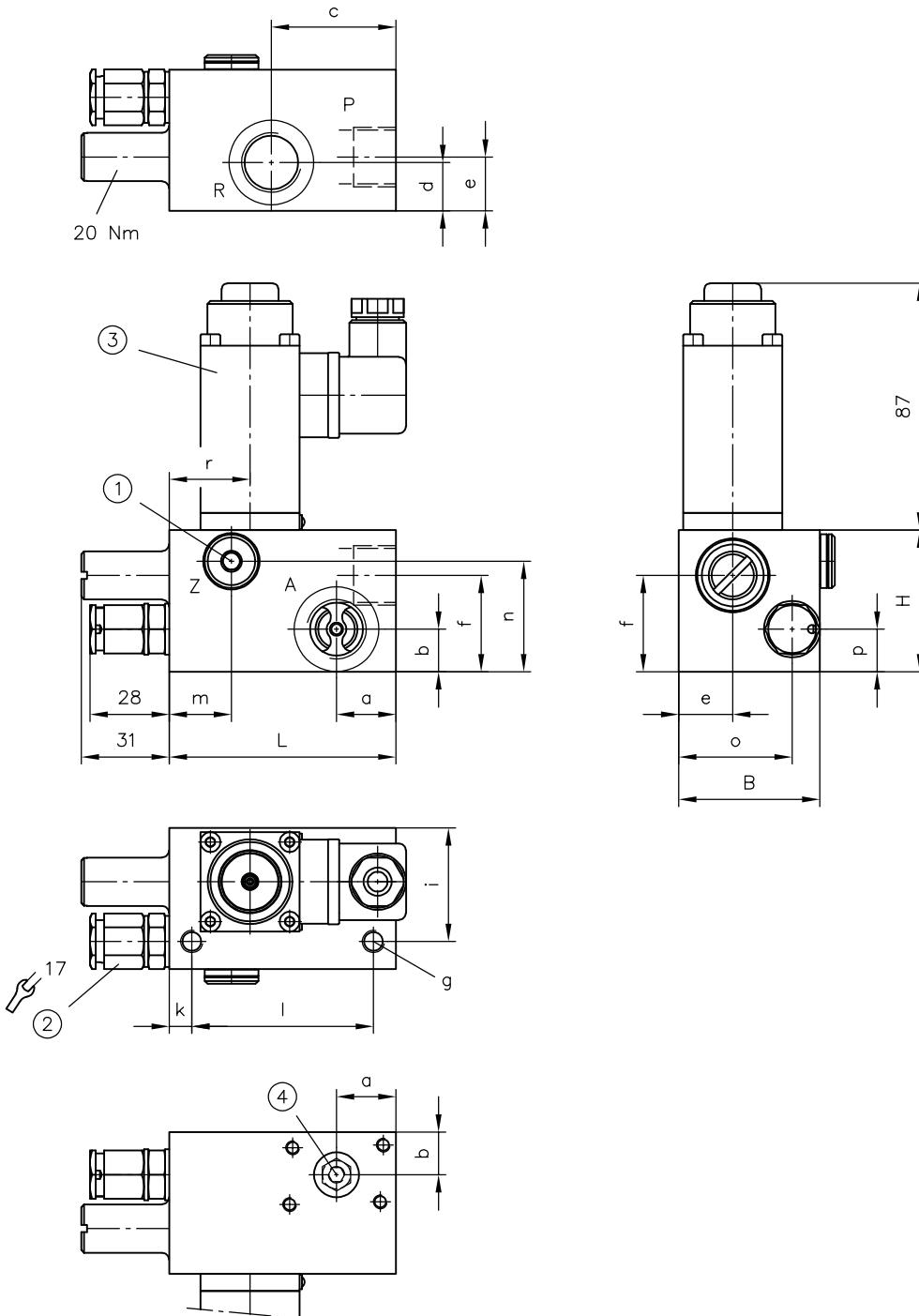

1 Pilot control port Z: only in conjunction with a pressure-limiting valve

2 Pressure-limiting valve for the version with coding S

3 Directional seated valve, see [D 7470 A/1](#)

4 see Chapter 4.3, "Actuations"

Size	L	B	H	a	b	c	d	e	f	g	i	k	l
3	80	50	50	21	15	44	17	19	34	M8, 8 deep	40	8	64
4	85	60	60	25	19	53	21	21	41	M8, 10 deep	48	10	65
5	100	70	70	27	24	60	23	23	47	M10, 12 deep	52	20	60

Size	m	n	o	p	r	Ports (ISO 228-1)
						A, P, R
3	22	39	40	15	28.5	G 1/2
4	30	41	46	23	28.5	G 3/4
5	30	47	54.7	24	29.5	G 1

Pressure setting range (bar)	Travel f_{max} (mm)	Δp (bar) per revolution
10 to 200	4	90
200 to 315	4	150

4.2.2 For manifold mounting

Standard version coding P without additional functions

S.. 3-3 P, S.. 3-4 P, S.. 3-5 P

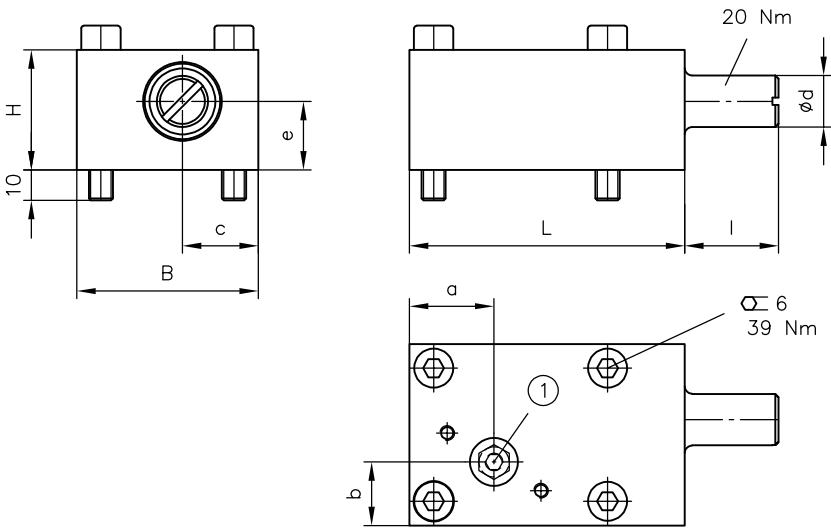

1 see Chapter 4.3, "Actuations"

Size	L	B	H	a	b	c	$\varnothing d$	e	l
3	93	60	40	28	21	25	17	22.75	31
4	97	70	49.75	35	26	28	17	28.75	31
5	106	80	49.8	33	28	32	24	26.75	29.7

Hole pattern of the base plate

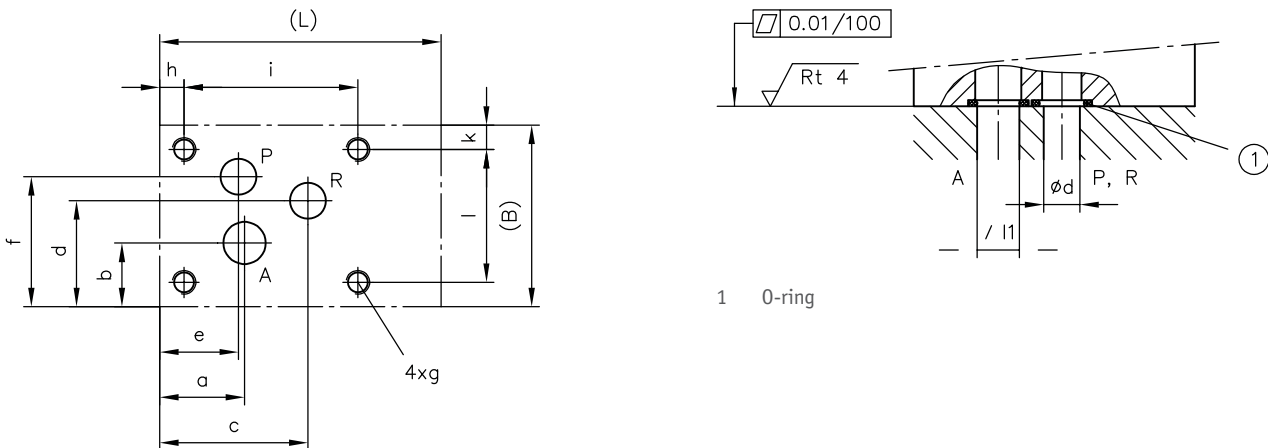

Size	L	B	a	b	c	e	f	h	i	k	l	g
3	93	60	28	21	49	26	43	8	57.5	8	44	M8, 10 deep
4	97	70	35	26	57	33.5	53	16	57	9	52	M10, 10 deep
5	106	80	33	28	65	33	62	9	88	8	64	M10, 10 deep

Size	Ød	Ød1	O-ring NBR 60 Sh	
			A	P, R
3	12	14	15x2.5	15x2.5
4	17	17	18.75x2.62	18.75x2.62
5	17	17	26x3	18.75x2.62

4.3 Actuators

4.3.1 Type SD

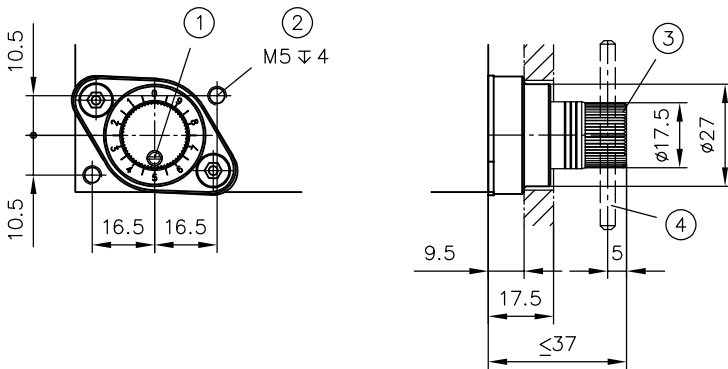

- 1 Locking screw
- 2 Mounting thread for switch panel installation
Version for switch panel installation is not available in the case of type S.. 2-3 B and all types with manifold mounting
- 3 Turning knob
- 4 To simplify operation, a $\varnothing 4 \times 50$ rolled pin can be inserted into the $\varnothing 4.3$ transverse hole.

4.3.2 Type SF

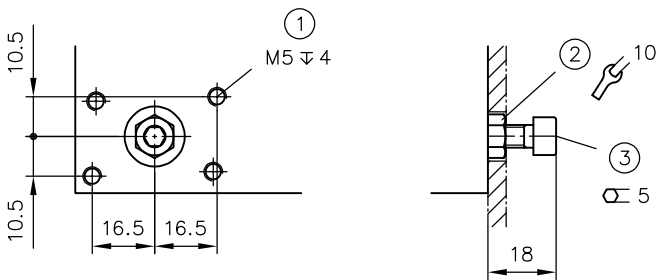

- 1 Mounting thread for switch panel installation
Version for switch panel installation is not available in the case of type S.. 2-3 B and all types with manifold mounting
- 2 Counter screw
- 3 Adjusting screw

4.3.3 Type SK

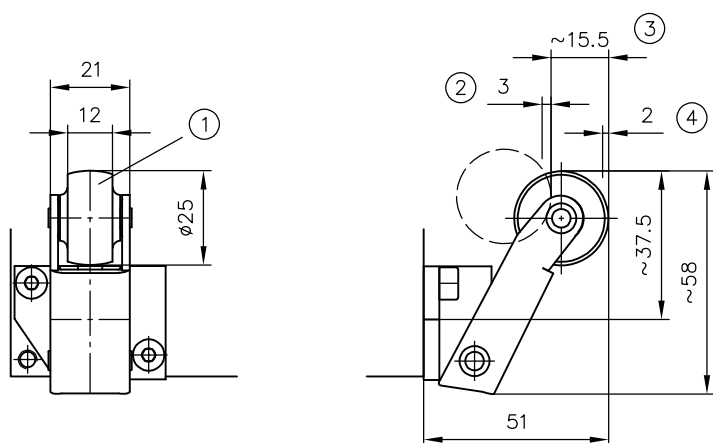

- 1 Roller
- 2 Safety stroke
- 3 Switching travel
- 4 Idle stroke

4.3.4 Type SKR

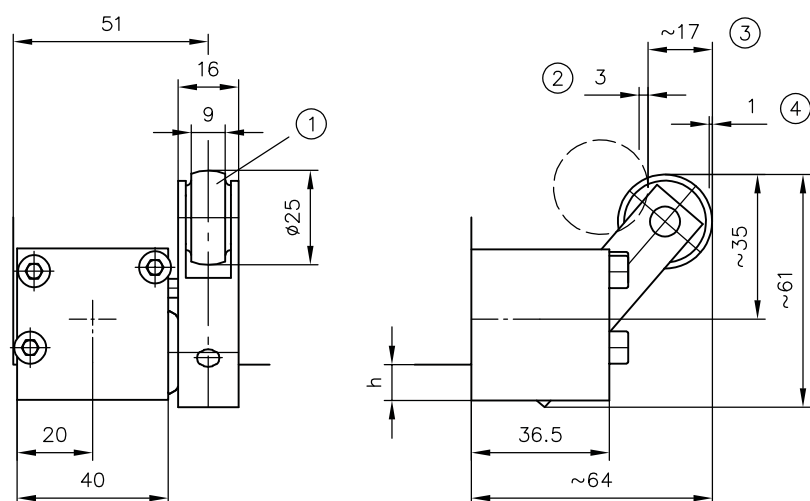

- 1 Roller
- 2 Safety stroke
- 3 Switching travel
- 4 Idle stroke

Size	h
3	9.5
4	13.5
5	2.5

Observe the document B 5488 "General operating instructions for assembly, commissioning, and maintenance."

5.1 Intended use

This product is intended exclusively for hydraulic applications (fluid technology).

The user must observe the safety measures and warnings in this document.

Essential requirements for the product to function correctly and safely:

- ▶ All information in this documentation must be observed. This applies in particular to all safety measures and warnings.
- ▶ The product must only be assembled and put into operation by specialist personnel.
- ▶ The product must only be operated within the specified technical parameters described in detail in this document.
- ▶ All components must be suitable for the operating conditions when using an assembly.
- ▶ The operating instructions for the components, assemblies and the specific complete system must also always be observed.

If the product can no longer be operated safely:

1. Remove the product from operation and mark it accordingly.
 - ✓ It is then not permitted to continue using or operating the product.

5.2 Assembly information

The product must only be installed in the complete system with standard and compliant connection components (screw fittings, hoses, pipes, fixtures etc.).

The product must be shut down correctly prior to disassembly (in particular in combination with hydraulic accumulators).

DANGER

Sudden movement of the hydraulic drives when disassembled incorrectly

Risk of serious injury or death

- ▶ Depressurise the hydraulic system.
- ▶ Perform safety measures in preparation for maintenance.

5.3 Operating instructions

Observe product configuration and pressure/flow rate.

The statements and technical parameters in this document must be strictly observed.

The instructions for the complete technical system must also always be followed.

NOTICE

- ▶ Read the documentation carefully before usage.
- ▶ The documentation must be accessible to the operating and maintenance staff at all times.
- ▶ Keep documentation up to date after every addition or update.

CAUTION

Overloading components due to incorrect pressure settings.

Risk of minor injury. Parts may burst or fly off, and uncontrolled leakage of hydraulic fluid.

- Pay attention to the maximum operating pressure of the pump, valves and fittings.
- Always monitor the pressure gauge when setting and changing the pressure.

Purity and filtering of the hydraulic fluid

Fine contamination can significantly impair the function of the product. Contamination can cause irreparable damage.

Examples of fine contamination include:

- Swarf
- Rubber particles from hoses and seals
- Dirt due to assembly and maintenance
- Mechanical debris
- Chemical ageing of the hydraulic fluid

! NOTICE

New hydraulic fluid from the manufacturer may not have the required purity.

Damage to the product is possible.

- ▶ Filter new hydraulic fluid to a high quality when filling.
- ▶ Do not mix hydraulic fluids. Always use hydraulic fluid that is from the same manufacturer, of the same type, and with the same viscosity properties.

For smooth operation, pay attention to the cleanliness level of the hydraulic fluid (cleanliness level [see Chapter 3, "Parameters"](#)).

Additionally applicable document: [D 5488/1](#) oil recommendations

5.4 Maintenance information

Check regularly (at least once a year) by visual inspection whether the hydraulic connections are damaged. If external leakages are found, shut down and repair the system.

Clean the surface of the device regularly (at least once a year) (dust deposits and dirt).

6 Other information

6.1 Structure and functional principle

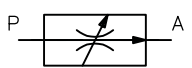
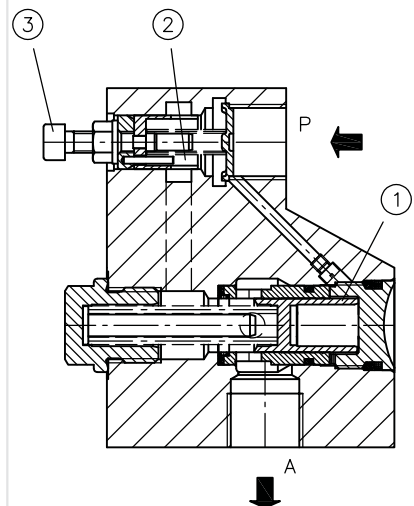
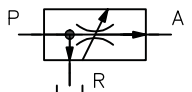
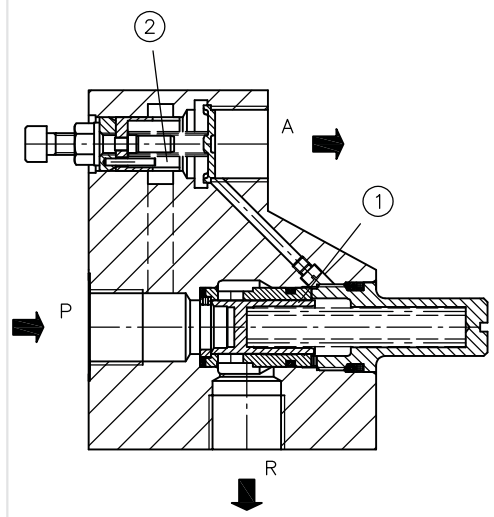
Version	Schematic diagram	Design
<p>2-way flow control valve (flow control valve connected in series, secondary pressure)</p> 	<ul style="list-style-type: none"> ▪ Turning knob type SD.. ▪ Adjusting screw type SF.. ▪ Roller lever type SK.. and SKR..  <p>1 Differential pressure controller 2 Metering orifice 3 Adjustment device</p>	<p>Secondary flow controller, meaning the differential pressure controller (pressure compensator) is fitted downstream of the metering orifice to provide good dynamic damping. A 2-way flow control valve will operate only in conjunction with a pressure-limiting valve on the inflow side P, and may therefore be used for both inflow and outlet control.</p> <div style="border: 1px solid black; padding: 5px; margin-top: 10px;"> <p>NOTICE Observe the notes in Chapter 2, "Available versions" and Chapter 6.2, "Circuit examples"!</p> </div> <p>Versions with bypass check valve for unhindered return flow or check valve bridge rectifier (enabling control of both flow directions) are available.</p>
<p>3-way flow control valve (flow control valve connected in parallel)</p> 	 <p>1 Differential pressure controller 2 Metering orifice</p>	<p>The differential pressure controller (pressure compensator) and metering orifice are arranged in parallel. Contrary to the 2-way flow control valve, the oil flow is separated into the consumer flow (→ A) and residual flow (→ R) in the flow controller itself, meaning it can only be used for controlling the inflow. The control function acts against the current consumer counter-pressure. Additional control functions in the form of a pressure-limiting valve or idle circulation valve can be provided via mounted pilot valves or remote control via control port Z.</p>

6.2 Circuit examples

Inflow control with 3-way flow control valve and pressure-limiting valve (coding S)

Simultaneous pressure safeguard

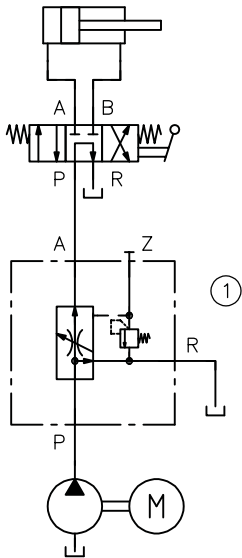

1 Type SD 3-3/36 S

Inflow control with 3-way flow control valve, pressure-limiting valve and idle circulation valve (coding S-WN..)

Simultaneous pressure safeguard and idle circulation

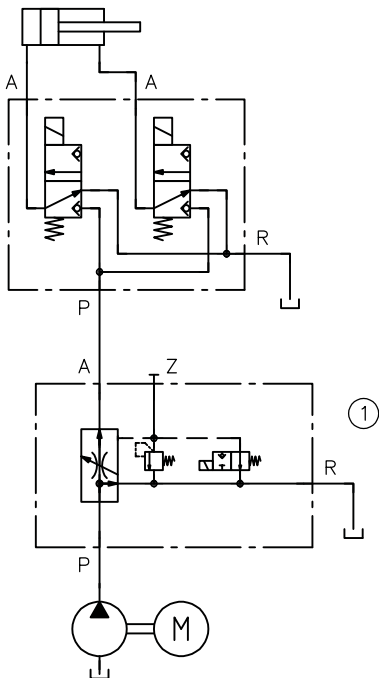

1 Type SD 3-3/15 S-WN 1 F

Speed control in both directions due to bridge rectifier (coding B)

The flow speed and reflux speed are identical. The following pressure amplification applies for versions with the flow control valve on the outlet side (A_3). In this case, the pressure amplification will be too high when running without load.

$$p_A = \varphi \left(p_{max} - \frac{F}{A_1} \right)$$

where $\varphi = A_1 / A_3$ and F = load resistance

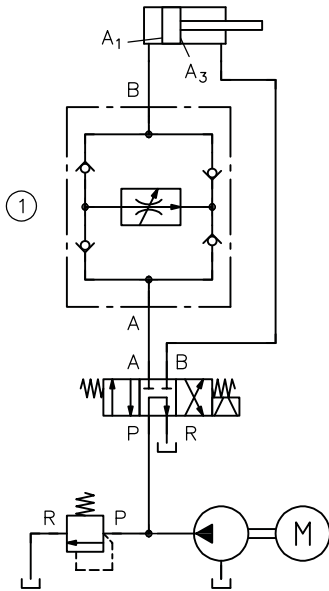

1 Type SD 2-3/30 B

Outlet control with 2-way flow control valve and bypass check valve coding R

A 2-way flow control valve operates only in conjunction with a pressure-limiting valve on the inflow side. If the surface ratio $\varphi = A_1 / A_3$ is unequal, this will result in pressure amplification that depends on the load resistance F on the outlet side (A_3). The pressure amplification will be too high when running without load.

$$p_A = \varphi \left(p_{max} - \frac{F}{A_1} \right)$$

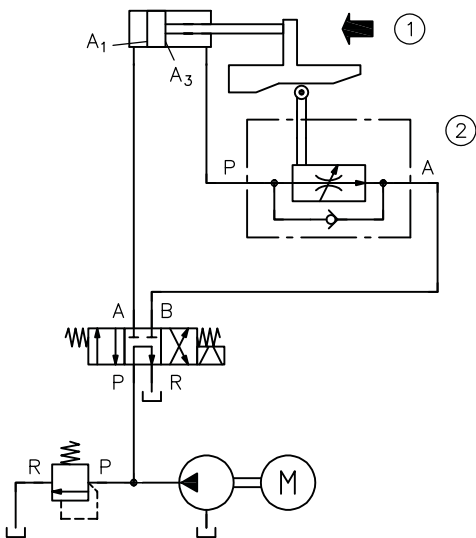

1 Load resistance
2 Type SK 2-3/15 R

References

Additional versions

- Proportional flow control valve type SE and SEH: D 7557/1
- 2-way flow control valve type SR2 (size 8): D 6402
- 2-way flow control valve type SR2 (size 6): D 6403
- 3-way flow control valve type SR3 (size 6): D 6404

