

Releasable check valve type HRP

Product documentation



Relieved, manifold mounting

Operating pressure p_{\max} :

700 bar

Flow rate Q_{\max} :

400 lpm



© by HAWE Hydraulik SE.

The reproduction and distribution of this document as well as the use and communication of its contents to others without explicit authorization is prohibited.

Offenders will be held liable for the payment of damages.

All rights reserved in the event of patent or utility model applications.

Brand names, product names and trademarks are not specifically indicated. In particular with regard to registered and protected names and trademarks, usage is subject to legal provisions.

HAWE Hydraulik respects these legal provisions in all cases.

HAWE Hydraulik cannot provide individual guarantees that the stated circuits or procedures (including in part) are not subject to the intellectual property rights of third parties.

Printing date / document generated on: 24.08.2022

Table of Contents

1	Overview of releasable check valve type HRP.....	4
2	Available versions.....	5
2.1	Basic type and size.....	6
2.2	Optionally mounted directional seated valve.....	7
2.2.1	Circuit symbols.....	8
2.3	Orifice in the control port Z.....	9
2.4	Additional control port X.....	9
3	Parameters.....	10
3.1	General.....	10
3.2	Weight.....	11
3.3	Characteristic lines.....	11
4	Dimensions.....	13
4.1	Basic version.....	13
4.2	Version with directional seated valve.....	16
5	Installation, operation and maintenance information.....	18
5.1	Intended use.....	18
5.2	Assembly information.....	18
5.3	Operating instructions.....	18
5.4	Maintenance information.....	19
6	Other information.....	20
6.1	Accessories, spare and individual parts.....	20
6.2	Planning information.....	20

1**Overview of releasable check valve type HRP**

Check valves block volumetric flow in one direction while enabling it in the other direction.

In the closed state the check valve type HRP has zero leakage. An overflow oil line relieves the rear of the control piston. Due to this separate relief the control behaviour of the valve is independent of the pressure in the return.

A solenoid valve can be optionally flange-mounted to arbitrarily control the check valve with the load pressure on the consumer side. The check valve type HRP is available with hydraulic release. Hydraulic release suppresses relief surges that can occur at high pressure and with a large consumer volume.

Features and benefits

- Manifold mounting valve for pressures up to 700 bar
- Flow rates up to 400 lpm
- Can be controlled electrically
- With hydraulic release for smooth switching

Application areas

- Industrial hydraulics
- Mobile hydraulics



Releasable check valve type HRP

2 Available versions

Circuit symbol

HRP

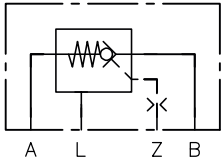

HRPD

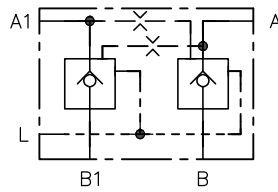

Ordering example

HRP 2		-B 0,4	
HRP 4V	-WG 3-0 B 0,4-WG 230		
HRP 7V			-X

2.1 "Basic type and size"

2.2 "Optionally mounted directional seated valve"

2.3 "Orifice in the control port Z"

2.4 "Additional control port X"

2.1 Basic type and size

Type		Description	Flow rate Q_{max} approx. (lpm)	Pressure range p_{max} (bar)		Control volume (cm ³)	Circuit symbol
Normal design	With hydraulic release			A, B, Z	L		
HRP 1	--	Single valve Manifold mounting	20	700	unpressurised to the tank	0.2	
HRP 2	--		35				
HRP 3	HRP 3V		50				
HRP 4	HRP 4V		80				
HRP 5	HRP 5V		140				
--	HRP 7V (-X)	Optionally mounted directional seated valve, see Chapter 2.2, "Optionally mounted directional seated valve"	400	500		13.8	<p>HRP 7V</p> <p>HRP 7V X</p>
--	HRPD 3V	Twin valve	50			0.5	<p>1 Orifice \varnothing 1.4</p>

2.2 Optionally mounted directional seated valve

3/2-way directional seated valve		Nominal voltage U_N	For mounting on	HRP is released if
According to D 7300 and D 7300-12	According to D 7470 A/1			
G 3-0 B 0.4 - G 24	WH 1H B 0.4 - G 24	24 V DC	HRP 4.., HRP 5..	Solenoid valve energised
WG 3-0 B 0.4 - WG 230	WH 1H B 0.4 - WG 230	230 V AC 50/60 Hz		
G 3-12 B 0.6 - GM 24	--	24 V DC	HRP 7V	
G 3-12 B 0.6 - WGM 230	--	230 V AC 50/60 Hz		
GZ 3-0 B 0.4 - G 24	WH 1M B 0.4 - G 24	24 V DC	HRP 4.., HRP 5..	Solenoid valve de-energised
WGZ 3-0 B 0.4 - WG 230	WH 1M B 0.4 - WG 230	230 V AC 50/60 Hz		
GZ 3-12 B 0.6 - GM 24	--	24 V DC	HRP 7V	
GZ 3-12 B 0.6 - WGM 230	--	230 V AC 50/60 Hz		
Reactive plate; port X sealed with tapped plug			HRP 7V - X	--

2.2.1 Circuit symbols

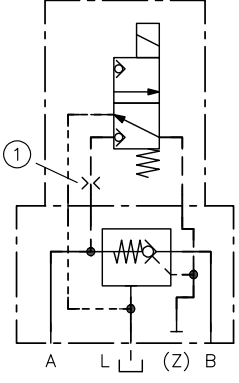
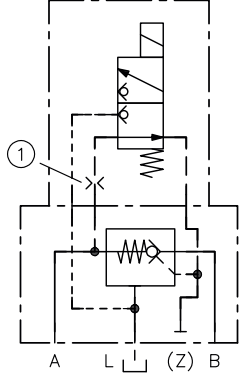
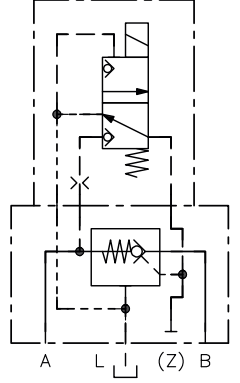
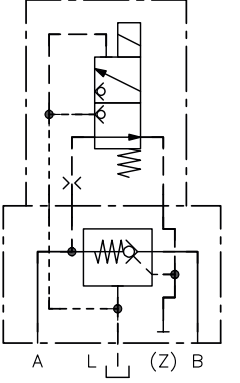
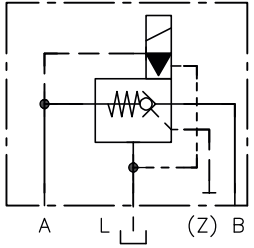
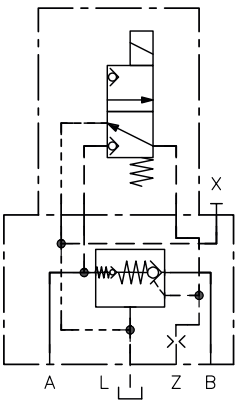
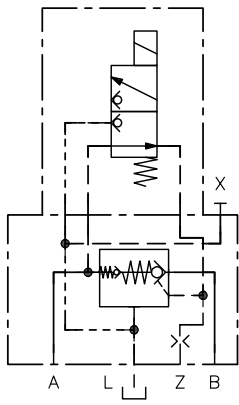
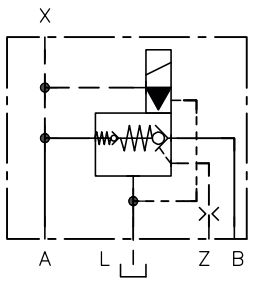
Type	With mounted directional seated valve				
HRP 1 HRP 2 HRP 3.. HRP 4.. HRP 5..	HRP..				
	-G 3-0	-GZ 3-0	-WH 1H	-WH 1M	
	-WG 3-0	-WZG 3-0			
					
	1 Orifice in directional seated valve				Simplified illustration (for circuit diagrams)
					
HRP 7V	HRP 7V..				
	-G 3-12	-GZ 3-12			
					Simplified illustration (for circuit diagrams)
					

2.3 Orifice in the control port Z

Coding	Type	Ø (mm)
B 0,4	HRP 1	0,4
B 0,6	HRP 2	0,6
B 0,8	HRP 3..	0,8
	HRP 4..	
	HRP 5..	
EB 1 - 0.4	HRP 7	0,4
EB 1 - 0.6		0,6
EB 1 - 0.8		0,8
EB 1 - 1.0		1,0
EB 1 - 2.0		2,0

Ordering example: HRP 2 -B 0,4

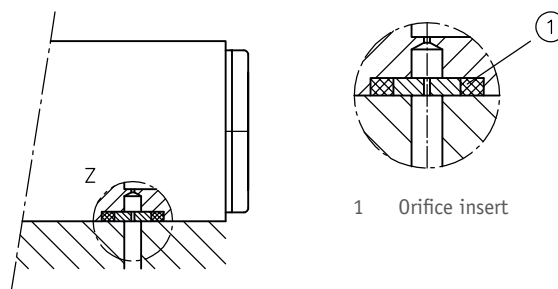

1 Orifice insert

i INFORMATION

Orifice inserts to prevent relief surges. It should be noted that excessively strong damping can increase the closing time of the opened valve.

2.4 Additional control port X

Type	Description	Connections
HRP 7V	Without port X	G 1/4
HRP 7V - X	With reactive plate and tapped plug	
HRP 7V - GZ 3-12 B 0.6 - GM 24	Port X open	

i INFORMATION

The orifice serves to protect the directional seated valve against overloading.

3.1 General

Designation	Releasable check valve, relieved
Design	Spring-loaded ball seated valve, zero-leakage
Model	Manifold mounting
Material	Balls made of rolling bearing steel Steel; electro-galvanised valve housing, hardened and ground functional inner parts
Installation position	any
Ports/connections	<ul style="list-style-type: none"> ▪ A, B = consumer (main passage) ▪ Z = control port ▪ L = drain port (piston chamber relief)
Hydraulic fluid	Hydraulic fluid, according to DIN 51 524 Parts 1 to 3; ISO VG 10 to 68 according to DIN ISO 3448 Viscosity range: 4 - 1500 mm ² /s Optimal operating range: approx. 10 - 500 mm ² /s Also suitable for biologically degradable hydraulic fluids type HEPG (polyalkylene glycol) and HEES (synthetic ester) at operating temperatures up to approx. +70°C.
Cleanliness level	ISO 4406 <hr style="width: 20%; margin-left: 0;"/> 21/18/15...19/17/13
Temperatures	Environment: approx. -40 to +80 °C, hydraulic fluid: -25 to +80 °C, pay attention to the viscosity range. Start temperature: down to -40 °C is permissible (take account of the start viscosities!), as long as the steady-state temperature is at least 20 K higher during subsequent operation. Biologically degradable hydraulic fluids: note manufacturer specifications. With consideration for the seal compatibility, not above +70°C.

i INFORMATION

With mounted directional seated valve and an ambient temperature of above 35 °C, observe the relevant notes in [D 7300](#), [D 7300-12](#) and [D 7470 A/1](#)!

3.2 Weight

Type

HRP 1	= approx. 0.3 kg
HRP 2	= approx. 0.4 kg
HRP 3..	= approx. 0.7 kg
HRPD 3V	= approx. 1.7 kg
HRP 4..	= approx. 1.2 kg
HRP 5..	= approx. 1.9 kg
HRP 7V	= approx. 7.9 kg
HRP 7V - X	= approx. 8.0 kg

Type

With directional seated valve

HRP 4..	-G(WG)..	= 0.4 kg
HRP 4..	-WH 1..	= 0.6 kg
HRP 5..	-G(WG)..	= 0.4 kg
HRP 5..	-WH 1..	= 0.6 kg
HRP 7V	-G..	= 0.7 kg

3.3 Characteristic lines

Viscosity of the hydraulic fluid approx. 60 mm²/s

For releasing

Control pressure p_{st} (bar) at port Z with $p_B = 0$ bar (pressure at port B)

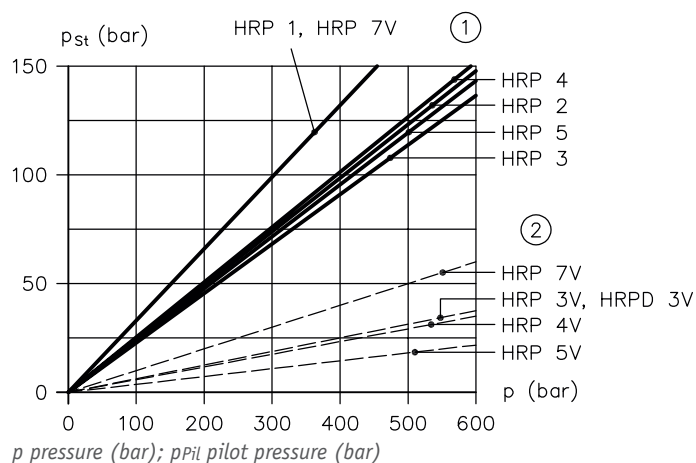

- 1 Releasing via main valve
- 2 Releasing via hydraulic release

For holding open

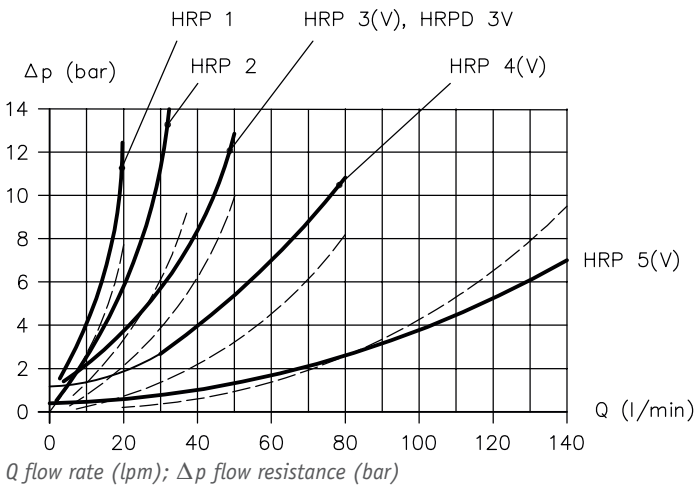

$$p_{st} = a \Delta p + b p_B + c$$

where

Δp = Flow resistance (bar)
A \rightarrow B acc. to Δp -Q characteristics

p_B = pressure (bar) at port B

Type	a	b	c
HRP 1	0,235	0,03	4,8
HRP 2	0,22	0,03	3,7
HRP 3 HRP 3V HRPD 3V	0,21	0,11	3,7
HRP 4 HRP 4V	0,235	0,07	3,0
HRP 5 HRP 5V	0,22	0,05	3,7
HRP 7V	0,32	0,04	3,2

HRP 7(V)

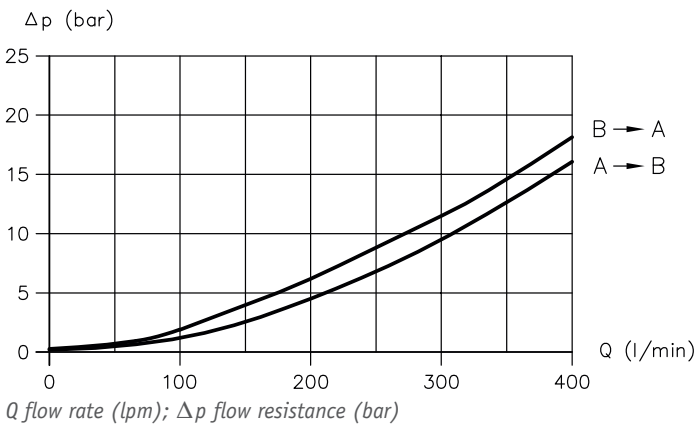

With hydraulic release

B \rightarrow A

A \rightarrow B

4 Dimensions

All dimensions in mm, subject to change.

4.1 Basic version

HRP 1, HRP 2, HRP 3, HRP 4, HRP 5

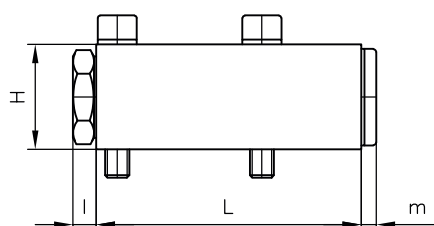

SW = Width across flats

Hole pattern of the base plate

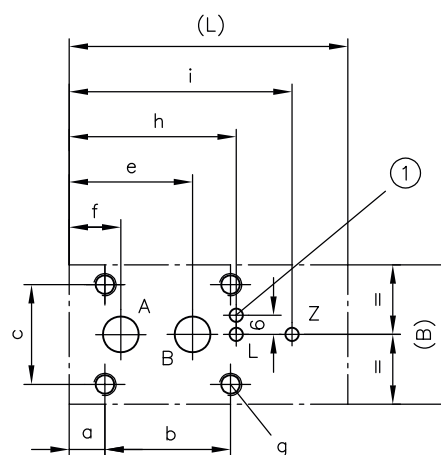

1 For HRP 3 and HRP 3V

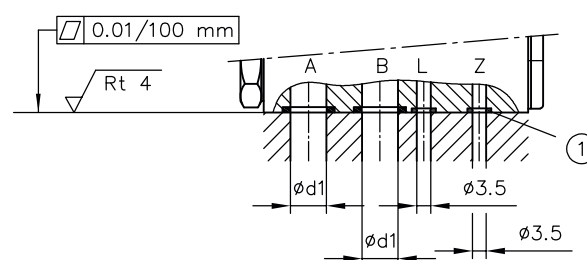

1 Sealing of the ports with O-ring NBR 90 Sh (see table)

Type	L	B	H	a	b	c	f	e	h	i	l	m	$\phi d1$	g
HRP 1	62	25	20	5,5	26	18	10	21	36	50	6	3,5	5	M4, 5 deep
HRP 2	65	30	25	7	24	22	12,5	26	38,5	52	9	4	6,5	M5, 5 deep
HRP 3..	70	35	35	9	26	25	13	31	42	56	9	4	9	M6, 10 deep
HRP 4..	88	50	35	7	48	38	17	37	53	71	10,5	5	11	M8, 10 deep
HRP 5..	102	60	40	10	48	42	21	44	62	85	13,5	5	14	

Type	Fastening screw	SW	Tightening torque (Nm)	Sealing with O-ring	
				A, B	L, Z
HRP 1	ISO 4762-M4x25-8.8-A2K	3	2,6	6.07x1.78	4.47x1.78
HRP 2	ISO 4762-M5x30-12.9-GEOMET 500	4	5	7.65x1.78	
HRP 3..	ISO 4762-M6x45-8.8-A2K	5	9	9.2x2.62	
HRP 4..	ISO 4762-M8x45-8.8-A2K	6	22	12.37x2.62	
HRP 5..	ISO 4762-M8x50-8.8-A2K			15.55x2.62	

HRPD 3V

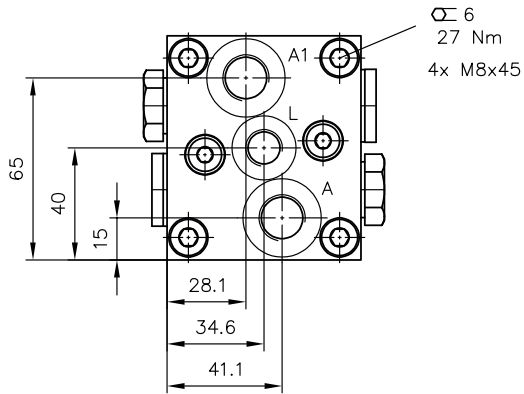
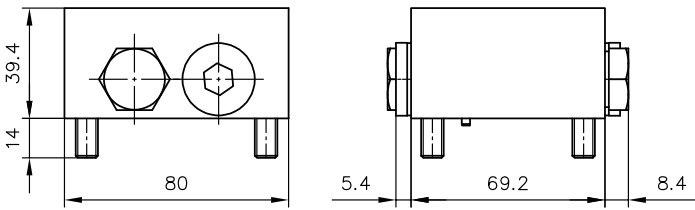

Hole pattern of the base plate

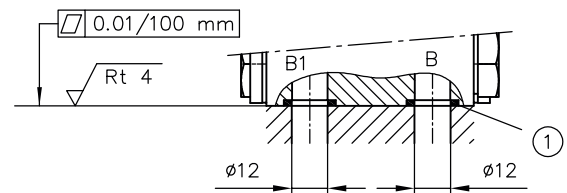
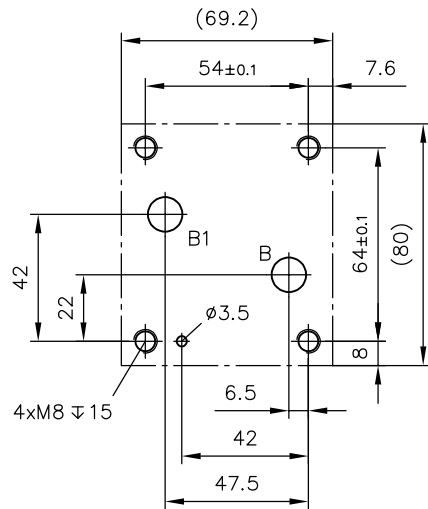

1 O-ring

Ports (ISO 228-1)

A, A1	G 3/8
L	G 1/4

HRP 7V, HRP 7V-X

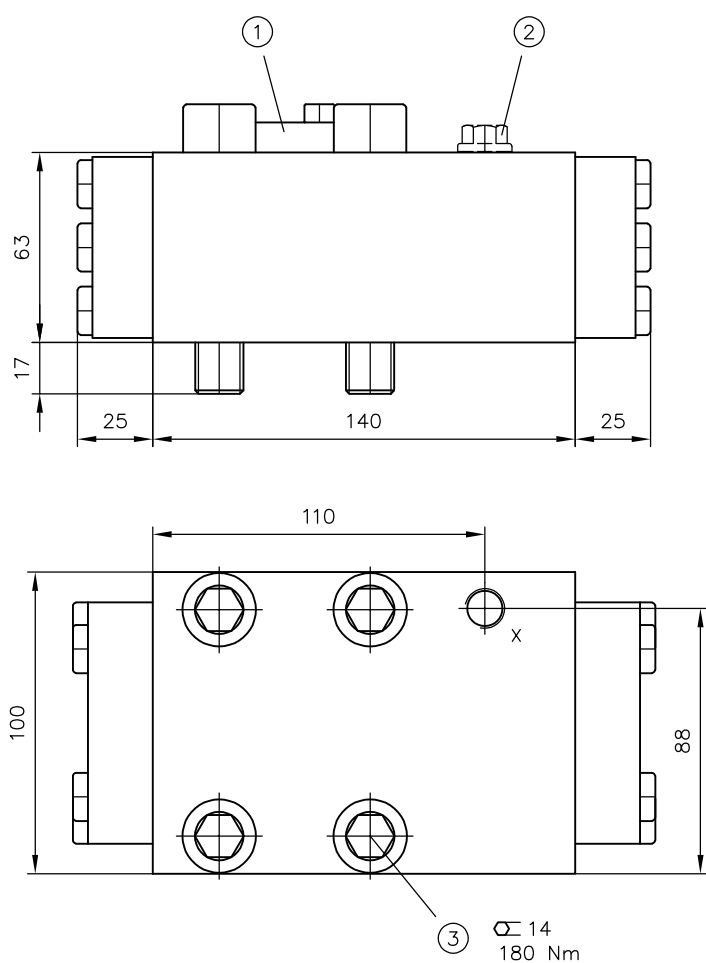

Hole pattern of the base plate

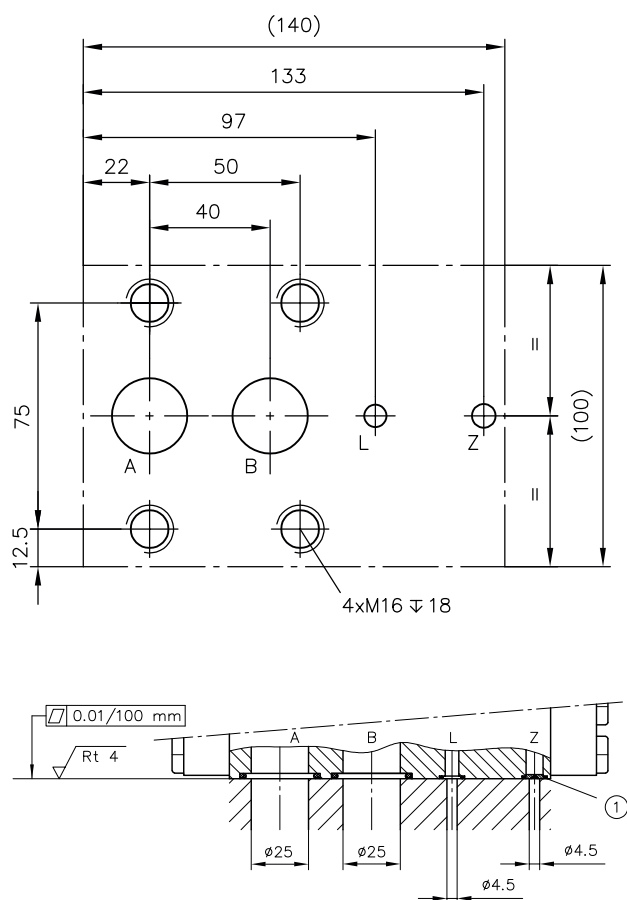

- 1 Reactive plate for HRP 7V-X
- 2 Port X (G 1/4) sealed for type HRP 7V-X.
- 3 Fastening screws ISO 4762-M16x80-8.8-A2K

- 1 Sealing of the ports with O-ring NBR 90 Sh (see table)

Type	Sealing with O-ring	
	A, B	L, Z
HRP 7V	29.2x3	8x1.5
HRP 7V-X		

4.2 Version with directional seated valve

HRP 4..- G(WG)..
HRP 5..- G(WG)..

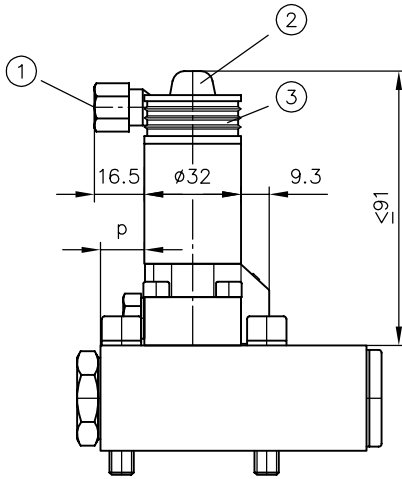

- 1 Suitable for cable $\phi 6$
- 2 Manual override
- 3 Plug can be mounted offset by 180°

For missing dimensions of directional seated valve (size 0) see D 7300.

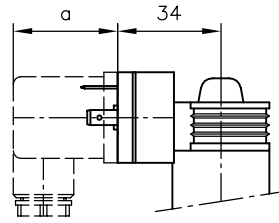

Coding	a
G..	28
WG..	34.5
L..	40

Type	p
HRP 4.. - G(WG)..	14.5
HRP 5.. - G(WG)..	17

HRP 4..- WH 1..
HRP 5..- WH 1..

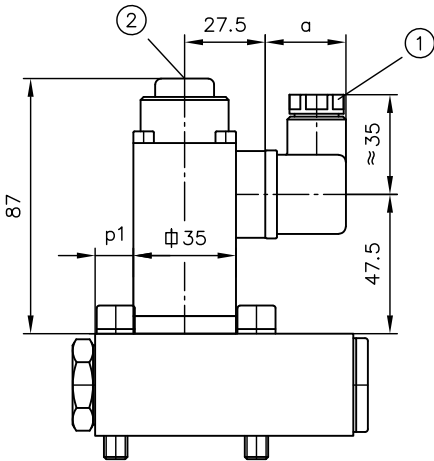

- 1 Plug x3, can be mounted offset by 90° , cable fitting
- 2 Manual override

For missing dimensions of directional seated valve type WH 1 see D 7470 A/1.

Coding	a
G..	28
WG..	34.5
L..	40

Type	p1
HRP 4.. -WH 1..	13
HRP 5.. -WH 1..	15,5

HRP 7V - G..

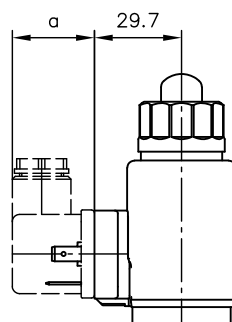
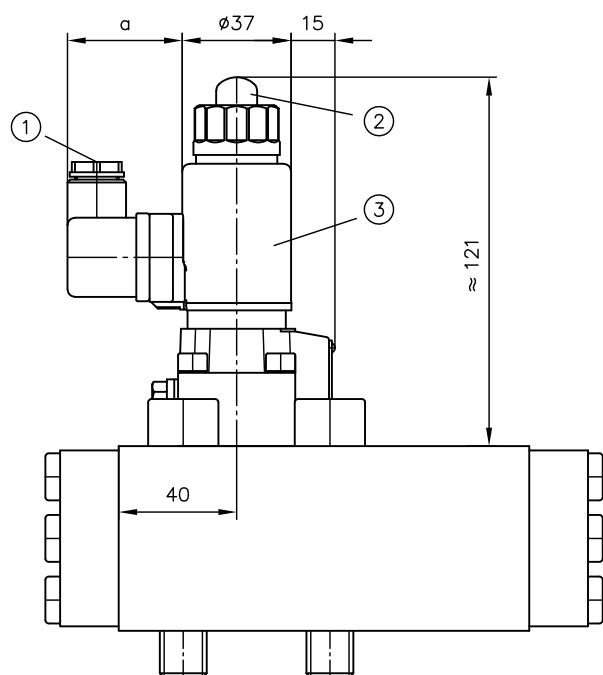

Coding	a
GM..	28
WGM..	34.5
LM..	40

- 1 Suitable for cable $\varnothing 6$
- 2 Manual override
- 3 Plug can be mounted offset by 180°

For missing dimensions of directional seated valve (size 12) see D 7300-12.

Observe the document B 5488 "General operating instructions for assembly, commissioning, and maintenance."

5.1 Intended use

This product is intended exclusively for hydraulic applications (fluid technology).

The user must observe the safety measures and warnings in this document.

Essential requirements for the product to function correctly and safely:

- ▶ All information in this documentation must be observed. This applies in particular to all safety measures and warnings.
- ▶ The product must only be assembled and put into operation by specialist personnel.
- ▶ The product must only be operated within the specified technical parameters described in detail in this document.
- ▶ All components must be suitable for the operating conditions when using an assembly.
- ▶ The operating instructions for the components, assemblies and the specific complete system must also always be observed.

If the product can no longer be operated safely:

1. Remove the product from operation and mark it accordingly.
 - ✓ It is then not permitted to continue using or operating the product.

5.2 Assembly information

The product must only be installed in the complete system with standard and compliant connection components (screw fittings, hoses, pipes, fixtures etc.).

The product must be shut down correctly prior to disassembly (in particular in combination with hydraulic accumulators).

DANGER

Sudden movement of the hydraulic drives when disassembled incorrectly

Risk of serious injury or death

- ▶ Depressurise the hydraulic system.
- ▶ Perform safety measures in preparation for maintenance.

5.3 Operating instructions

Observe product configuration and pressure/flow rate.

The statements and technical parameters in this document must be strictly observed.

The instructions for the complete technical system must also always be followed.

NOTICE

- ▶ Read the documentation carefully before usage.
- ▶ The documentation must be accessible to the operating and maintenance staff at all times.
- ▶ Keep documentation up to date after every addition or update.

CAUTION

Overloading components due to incorrect pressure settings.

Risk of minor injury.

- Pay attention to the maximum operating pressure of the pump and the valves.
- Always monitor the pressure gauge when setting and changing the pressure.

Purity and filtering of the hydraulic fluid

Fine contamination can significantly impair the function of the product. Contamination can cause irreparable damage.

Examples of fine contamination include:

- Swarf
- Rubber particles from hoses and seals
- Dirt due to assembly and maintenance
- Mechanical debris
- Chemical ageing of the hydraulic fluid

! NOTICE

New hydraulic fluid from the manufacturer may not have the required purity.

Damage to the product is possible.

- ▶ Filter new hydraulic fluid to a high quality when filling.
- ▶ Do not mix hydraulic fluids. Always use hydraulic fluid that is from the same manufacturer, of the same type, and with the same viscosity properties.

For smooth operation, pay attention to the cleanliness level of the hydraulic fluid (cleanliness level [see Chapter 3, "Parameters"](#)).

Additionally applicable document: [D 5488/1](#) Oil recommendations

5.4 Maintenance information

Check regularly (at least once a year) by visual inspection whether the hydraulic connections are damaged. If external leakages are found, shut down and repair the system.

Clean the surface of the device regularly (at least once a year) (dust deposits and dirt).

6 Other information

6.1 Accessories, spare and individual parts

To purchase spare parts, please see [HAWE Hydraulik interactive contact map](#).

Coding	Suitable for	Drawing no. Orifice
B 0,4	HRP 1 - 5	5585 038/1
B 0,6		5585 037/1
B 0,8		5585 034/1
EB 1 - 0 (undrilled)	HRP 7	5000 025
EB 1 - 0,4		5000 025 d
EB 1 - 0,6		5000 025 a
EB 1 - 0,8		5000 025 b
EB 1 - 1,0		5000 025 c
EB 1 - 2,0		5000 025 e

6.2 Planning information

Valves without hydraulic release

clear the full flow cross section relatively quickly when released. They are suitable for all normal operating cases. A restriction in the control port dampens the switching movement of the release piston, meaning that pressure surges (relief surges) are usually sufficiently suppressed. If they do still occur during the test run, the restriction of the release speed can be increased further with the additional incorporation of an orifice (see Chapter 2.3, "Orifice in the control port Z").

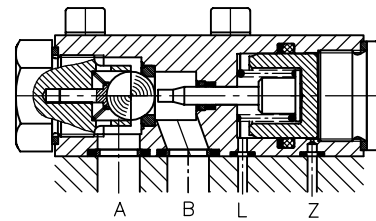

Valves with hydraulic release

are more suitable for high pressures and larger consumer volumes. The small ball check valve seated in the spherically ground main valve piston opens slightly earlier upon release, so that surge-free decompression can take place via the cross section, which acts as a throttle gap. The hydraulic release is all the more effective, i.e. the pressure reduction is all the smoother, the lower the opening speed of the control piston. With type HRP 7V, the lack of seals on the opening piston results in slight leakage from the control port Z to the drain port L. An additional orifice (see Chapter 2.3, "Orifice in the control port Z") in the control port can be useful in many cases.

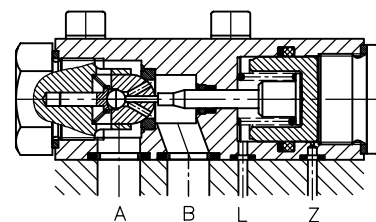

References

Additional versions

- Releasable check valve type RH: D 6105
- Releasable twin check valve type DRH: D 6110
- Releasable check valve type RHC and RHCE: D 7165
- Check valve type CRK, CRB and CRH: D 7712
- Directional seated valve type G, WG and others: D 7300
- Directional seated valve type G with interchangeable solenoid: D 7300-12
- Directional seated valve type WN and WH: D 7470 A/1
- Orifice type EB: D 6465

