

# Variable displacement axial piston pump type V60N

## Product documentation



Open circuit, for the power take-off of commercial vehicles

Nominal pressure  $p_{\text{nom max}}$ : 400 bar

Peak pressure  $p_{\text{max}}$ : 450 bar

Displacement volume  $V_{\text{max}}$ : 130 cm<sup>3</sup>/rev



© by HAWE Hydraulik SE.

The reproduction and distribution of this document, as well as the use and communication of its contents to others without explicit authorization, is prohibited.

Offenders will be held liable for the payment of damages.

All rights reserved in the event of patent or utility model applications.

Brand names, product names and trademarks are not specifically indicated. In particular with regard to registered and protected names and trademarks, usage is subject to legal provisions.

HAWE Hydraulik respects these legal provisions in all cases.

HAWE Hydraulik cannot provide individual guarantees that the stated circuits or procedures (including in part) are not subject to the intellectual property rights of third parties.

Printing date / document generated on: 2024-10-07

## Table of Contents

<b>1</b>	<b>Overview: variable displacement axial piston pump type V60N.....</b>	<b>5</b>
<b>2</b>	<b>Available versions.....</b>	<b>6</b>
2.1	Basic type and nominal size.....	6
2.2	Rotation direction.....	7
2.3	Shaft journal.....	7
2.4	Flange version (input side).....	8
2.5	Seals.....	8
2.6	Thru-shaft.....	8
2.7	Controller.....	9
2.7.1	Load-sensing controller LSP, LSPT.....	11
2.7.2	Delivery flow controller QP.....	14
2.7.3	Flow controller ZV, ZV1 and V.....	17
2.7.4	Pressure controller P, P3.....	20
2.7.5	Pressure controller Pe, Pe1, P3e, P3e1.....	23
2.7.6	Power controller ZL and L.....	26
2.7.7	ZLV and ZLV1 combined power and flow controller.....	28
2.7.8	ZW intermediate plate.....	29
2.8	Stroke limitation.....	30
2.9	Thread type.....	30
2.10	Flange version (output side).....	31
2.11	Solenoid voltage and connector.....	31
<b>3</b>	<b>Parameters.....</b>	<b>32</b>
3.1	General data.....	32
3.2	Weight.....	33
3.3	Pressure and delivery flow.....	34
3.4	Characteristic lines.....	34
3.4.1	Basic pump.....	34
3.4.2	Controllers.....	36
3.5	Electrical data.....	40
<b>4</b>	<b>Dimensions.....</b>	<b>42</b>
4.1	Basic pump.....	42
4.1.1	Type V60N-060.....	42
4.1.2	Type V60N-090.....	48
4.1.3	Type V60N-110 series 03.....	56
4.1.4	Type V60N-110 series 04 / V60N-130.....	63
4.2	Controllers and intermediate plates.....	68
<b>5</b>	<b>Installation, operation and maintenance information.....</b>	<b>71</b>
5.1	Intended use.....	71
5.2	Assembly information.....	71
5.2.1	General information.....	71
5.2.2	Connections.....	72
5.2.3	Installation positions.....	73
5.2.4	Tank installation.....	74
5.3	Operating instructions.....	75
5.4	Maintenance information.....	76

<b>6</b>	<b>Other information.....</b>	<b>77</b>
6.1	Accessories, spare and individual parts.....	77
6.1.1	Suction intake.....	77
6.1.2	Coupling flange for cardan shafts.....	78
6.2	Planning information.....	79

**1**
**Overview: variable displacement axial piston pump type V60N**

Variable displacement axial piston pumps adjust the geometric output volume from maximum to zero. As a result they vary the flow rate that is provided to the consumers.

The variable displacement axial piston pump type V60N is designed for open circuits in mobile hydraulics and operates according to the swash plate principle. It is available with the option of a thru-shaft for operating with additional hydraulic pumps in series.

The range of pump controllers allows the axial piston pump to be used in a variety of applications.

**Features and advantages**

- Optimized power-to-weight ratio
- Broad selection of controllers
- Slim design matching PTO (power take-off)
- Thru-shaft compatibility
- High self-suction speed

**Intended applications**

- Municipal trucks
- Fire trucks
- Loading cranes and lifting platforms
- Tipper trucks and skip trucks
- Suction dredgers and sewer cleaning vehicles

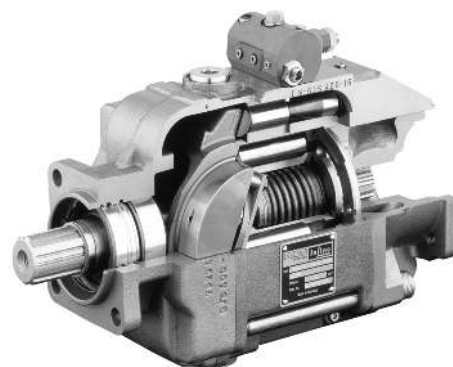

*Variable displacement axial piston pump type V60N-95*



*Variable displacement axial piston pump type V60N-130*

## 2 Available versions

### Circuit symbol

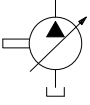

### Ordering example

V60N-090	R	D	Y	N	-2	-0	03	/LSP/ZL	-2/65	-350	-	A00/76	-C 022
													2.10 "Flange version (output side)"
													6.1.1 "Suction intake"
													2.9 "Thread type"
													<b>Pressure setting (nominal pressure) (bar)</b>
													2.8 "Stroke limitation"
													2.7 "Controller"
													<b>Manufacturing series</b>
													<b>No additional function</b>
													2.6 "Thru-shaft"
													2.5 "Seals"
													2.10 "Flange version (output side)"
													2.3 "Shaft journal"
													2.2 "Rotation direction"
													2.1 "Basic type and nominal size"

### 2.1 Basic type and nominal size

Coding	Displacement volume $V_{\max}$ (cm <sup>3</sup> /rev)	Nominal pressure $p_{\text{nom max}}$ (bar)	Peak pressure $p_{\text{max}}$ (bar)
060	60	350	400
090	90	350	400
110 series 03	110	350	400
110 series 04	110	400	450
130	130	400	450

## 2.2 Rotation direction

Coding	Description
L	Anti-clockwise
R	Clockwise

When looking at the shaft journal.

## 2.3 Shaft journal

Coding	Description	Designation/standard	Max. drive torque (Nm)
D	Parallel key splined shaft	Similar to DIN ISO 14 (for HGV) B8x32x35	800
M	Spline shaft	W30x2x14x9g DIN 5480 (only V60N-090, V60N-110)	530
H	Spline shaft	SAE-B J 744 13T 16/32 DP 22-4 DIN ISO 3019-1 (only V60N-060)	210
U	Spline shaft	SAE-B J 744 short 13T 16/32 DP 22-4 DIN ISO 3019-1 short (only V60N-060)	210
T	Spline shaft	SAE-BB J 744 15T 16/32 DP 25-4 DIN ISO 3019-1 (only V60N-060)	340
S	Spline shaft	SAE-C J 744 14T 12/24 DP 32-4 DIN ISO 3019-1	640
Q	Spline shaft	SAE-CS 21T 16/32 DP 35-4 DIN ISO 3019-1 (only V60N-090, V60N-110, V60N-130)	900

## 2.4 Flange version (input side)

Coding	Description	Designation
Y	Flange	DIN ISO 7653 (for HGV)
P	Flange	DIN ISO 7653 -10° rotated (for lorries) (only V60N-110, V60N-130) *
X	Flange	SAE-B 2-Loch J 744 -45° rotated 101-2 DIN ISO 3019-1 (only V60N-060)
Z	Flange	SAE-B 4-Loch J 744 101-4 DIN ISO 3019-1 (only V60N-060)
F	Flange	SAE-C 4-Loch J 744 127-4 DIN ISO 3019-1
G	Flange	125 B4 HW DIN ISO 3019-2 (only V60N-090, V60N-110)

\* In particularly tight installation situations, a flange that is turned by 10° can be used to prevent a collision with the cardan shaft.

## 2.5 Seals

Coding	Description
N	NBR (gearbox-side shaft seal made of FKM, pump-side shaft seal and other NBR seals)
V	FKM

## 2.6 Thru-shaft

Coding	Description
1	Suction and pressure connection axial
2	Suction and pressure connection radial, with thru-shaft
3	Suction and pressure connection radial
4	Suction and pressure port axial, ports SAE J 518 (only V60N-090)

## 2.7 Controller

### Load-sensing controller

Coding	Description
LSP	Load-sensing controller with integrated pressure limitation (Standard version for combination with hydraulic valves that relieve the LS signal in the valve, for example, type PSV proportional directional spool valve) see Chapter 2.7.1, "Load-sensing controller LSP, LSPT"
LSPT	Load-sensing controller with integrated pressure limitation and additional LS relief (only for use with hydraulic valves without their own relief of the LS signal) see Chapter 2.7.1, "Load-sensing controller LSP, LSPT"

### Delivery flow controller

Coding	Description
QP/...	Flow controller with integrated pressure limitation for setting a constant flow rate independently of the speed. see Chapter 2.7.2, "Delivery flow controller QP"
ZV	Size <b>060, 090, 110</b> : Electro-proportional delivery flow controller with increasing characteristic line (intermediate plate). Only in combination with a pressure controller (coding P) see Chapter 2.7.3, "Flow controller ZV, ZV1 and V"
ZV1	Size <b>060, 090, 110</b> : Electro-proportional delivery flow controller with decreasing characteristic curve (intermediate plate). Only in combination with a pressure controller (coding P). see Chapter 2.7.3, "Flow controller ZV, ZV1 and V"
V	Size <b>130</b> : Electro-proportional delivery flow controller with increasing characteristic curve. Only in combination with a pressure controller (coding P3) see Chapter 2.7.3, "Flow controller ZV, ZV1 and V"

### Pressure controller

Coding	Description
P	Mechanically adjustable pressure controller (standard version). see Chapter 2.7.4, "Pressure controller P, P3"
P3	Mechanically adjustable pressure controller. Only in combination with type V flow controllers. see Chapter 2.7.4, "Pressure controller P, P3"
Pe, P3e	Electro-proportional pressure controller with increasing characteristic curve. Cannot be combined with other pump controllers! see Chapter 2.7.5, "Pressure controller Pe, Pe1, P3e, P3e1"
Pe1, P3e1	Size <b>060, 090, 110</b> : Electro-proportional pressure controller with falling characteristic curve. Cannot be combined with other pump controllers! see Chapter 2.7.5, "Pressure controller Pe, Pe1, P3e, P3e1"

### Power controller

Coding	Description
ZL	Size <b>060, 090, 110</b> : Power controller (intermediate plate). Only in combination with a flow controller or pressure controller see Chapter 2.7.6, "Power controller ZL and L"
L	Size <b>130</b> : Power controller (as standard) Only in combination with a flow controller or pressure controller see Chapter 2.7.6, "Power controller ZL and L"

## Intermediate plate

Coding	Description
ZW	<p>Size <b>060, 090, 110</b>: 45° angle intermediate plate</p> <p>Standard for housing versions -2 and -3, to avoid a collision between the pump controller and the suction or pressure line.</p> <p>Only in combination with a flow controller or pressure controller see Chapter 2.7.8, "ZW intermediate plate"</p>

## Structure

### V60N-110/130

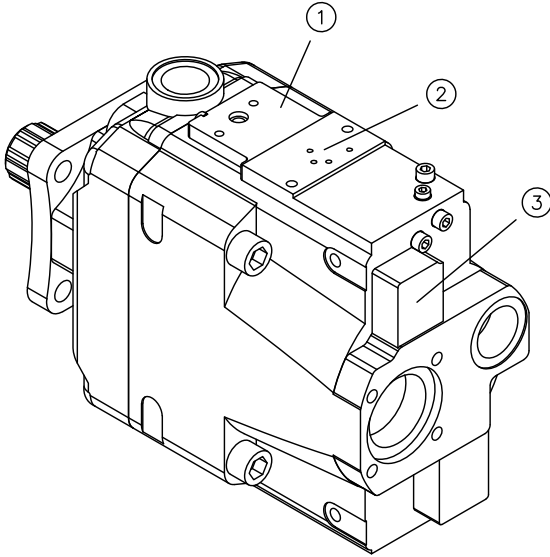

- 1 Type L controller mounting point
- 2 Type LSP, LSPT, QP, P, P3, Pe, Pe1, P3e, P3e1, ZW controller mounting point
- 3 Type V controller mounting point

### V60N-060/090

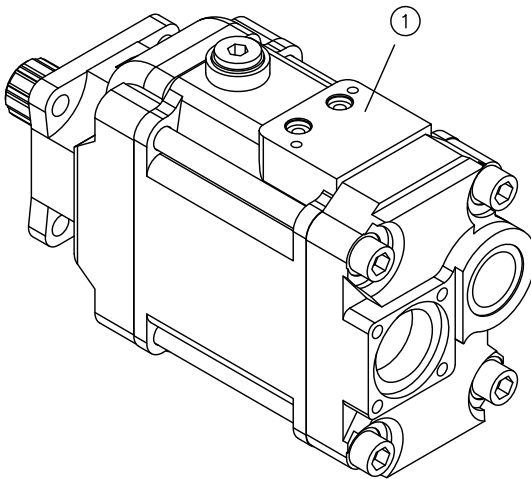

- 1 Type LSP, LSPT, P, QP, Pe, Pe1, P3e, P3e1, ZW, ZL, ZV, ZV1, ZLV controller mounting point

## 2.7.1 Load-sensing controller LSP, LSPT

The LSP and LSPT controllers are flow controllers that generate a variable, speed-independent flow rate. They adapt the displacement volume of the pump to the required flow rate of the consumer and regulate a constant difference between load pressure and pump pressure.

The integrated pressure limitation restricts the maximum pressure to a set value.

The LSP and LSPT controllers are further developments based on the LSNR and LSNRT controllers. They offer better control behaviour and a two-part dynamic screw for individual adjustment of the on-stroke and destroke velocities.

### LSP

- Connection X-R sealed
- Standard version for combination with hydraulic valves that relieve the LS signal in the valve, for example proportional directional spool valve type PSV

### LSPT

- Connection X-R open
- Only for use with hydraulic valves without their own relief of the LS signal

### LSP

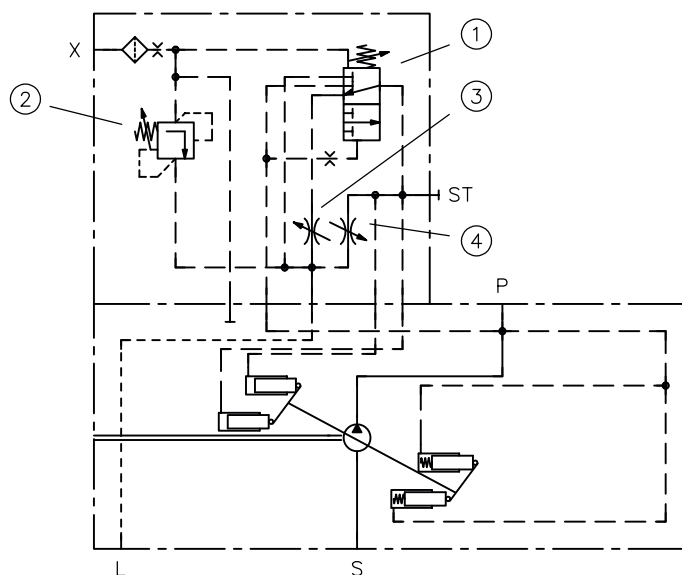

### LSPT

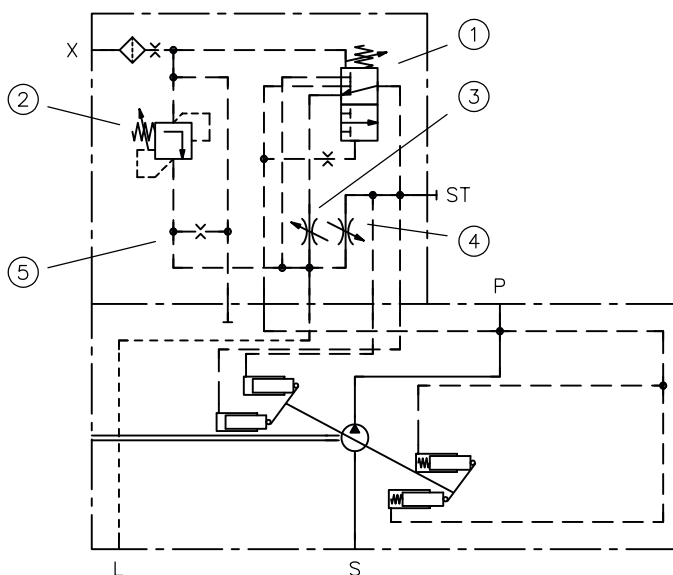

- 1 Flow controller: Regulates a constant difference between load pressure and pump pressure
- 2 Pressure limitation: Limits the pump pressure to a maximum value
- 3 Return throttle
- 4 Bypass throttle
- 5 LS signal relief

LSP, LSPT

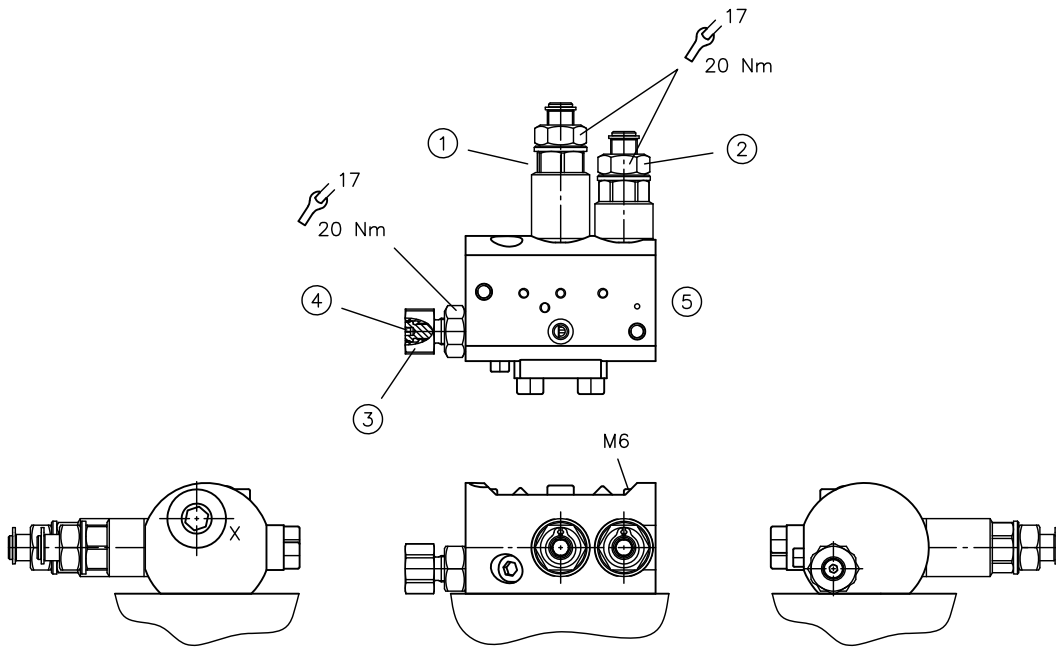

Adjustment range for ① and ② restricted by retaining ring.

- 1 Differential pressure  $\Delta p$  (stand-by pressure)
- 2 Maximum pressure  $p_{max}$  (pressure limitation)
- 3 Return throttle
- 4 Bypass throttle
- 5 X port for LS signal: G 1/4  
Order coding for adapter to 9/16-18 UNF (SAE-6): 7993245.00

## Dynamic throttle

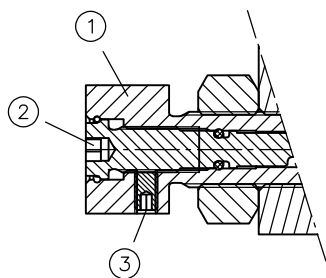

- 1 Return throttle (17-mm hex bolt)
- 2 Bypass throttle (3-mm hex socket)
- 3 Counter screw (1.5-mm hex socket)

### Description of the two-part dynamic screw

- While the pump is swinging out, the return throttle (outer screw on the two-part dynamic screw) adjusts the on-stroke time from  $V_{g \text{ min}}$  to  $V_{g \text{ max}}$ .
  - Loosening the screw reduces the damping and accelerates the on-stroke time.
  - Adjustment range: Approx. 5.5 rotations/4 mm
- While the pump is swinging in, a bypass throttle (inner screw on the two-part dynamic screw) adjusts the destroke time from  $V_{g \text{ max}}$  to  $V_{g \text{ min}}$ .
  - Loosening the screw increases the damping and slows down the destroke time.
  - Tightening the screw reduces the damping and accelerates the destroke time.
  - Adjustment range: Approx. 4 rotations/2 mm

Pressure adjustment	Pressure range (bar)	$\Delta p$ (bar)/revolution	Factory-set pressure setting (bar)
Maximum pressure $p_{\text{max}}$	20 ... 400	approx. 50	300
Differential pressure $\Delta p$	20 ... 55	approx. 10	27

### CAUTION

#### Overloading components due to incorrect pressure settings.

Risk of minor injury. Parts may burst or fly off, and uncontrolled leakage of hydraulic fluid.

- Pay attention to the maximum operating pressure of the pump, valves and fittings.
- Always monitor the pressure gauge when setting and changing the pressure.

## 2.7.2 Delivery flow controller QP

The QP controller is a flow controller that generates a constant flow rate independently of the speed. It regulates a constant differential pressure via an orifice in the P channel. The differential pressure is adjustable between 20 and 55 bar. The orifice is available in various graduations (see table).

The integrated pressure limitation restricts the maximum pressure to a set value.

### QP

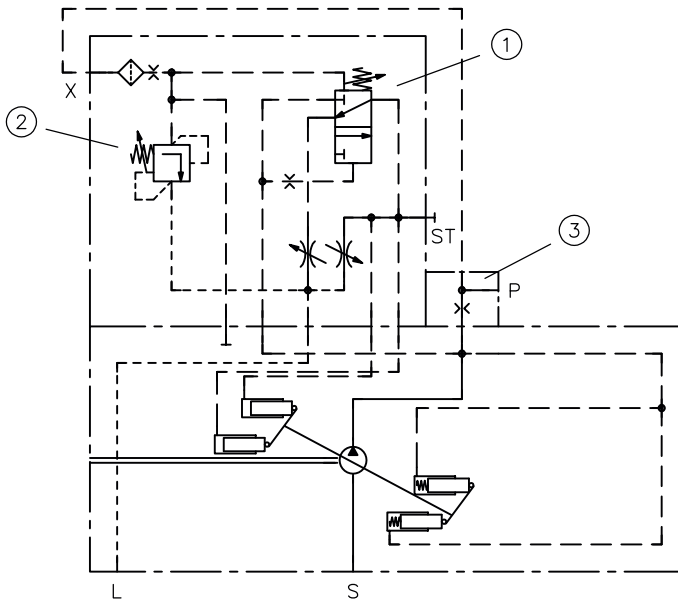

- 1 Flow controller: Regulates a constant differential pressure before and after the orifice
- 2 Pressure limitation: Limits the pump pressure to a maximum value
- 3 Orifice according to table

**Ordering example:** V60N-110 RDYN-1-0-03/QP/5-350

Orifice Ø (mm)	Flow rate (l/min) at 20 bar differential pressure
3	23
3,5	32
4	42
4,5	53
5	65
5,5	79
6	94
6,5	110
7	127
7,5	146
8	166
8,5	188
9	210
9,5	234
10	260

QP

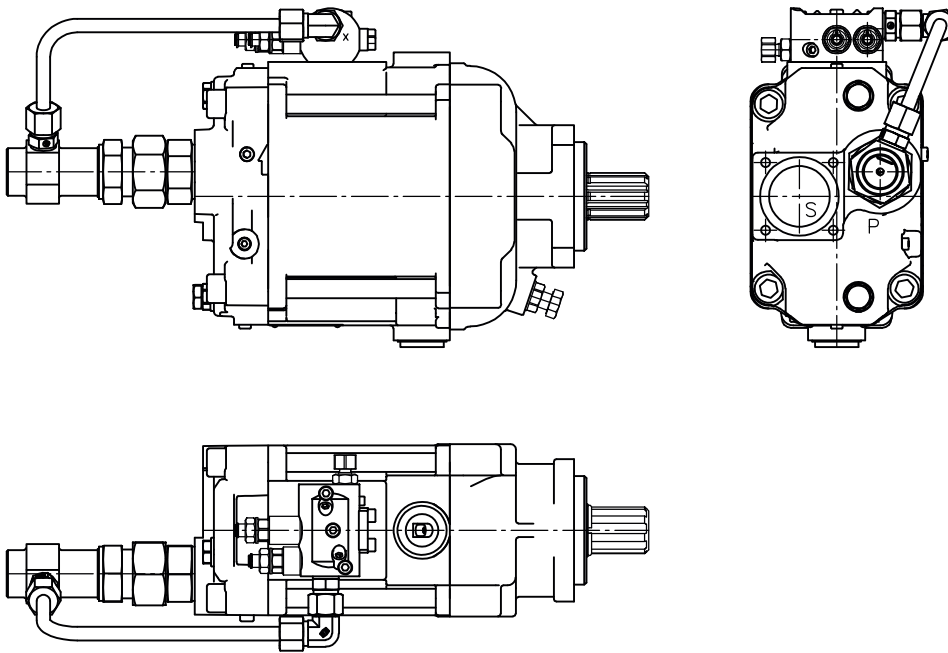

**i** INFORMATION

The hoses vary depending on the size and rotation direction.

QP

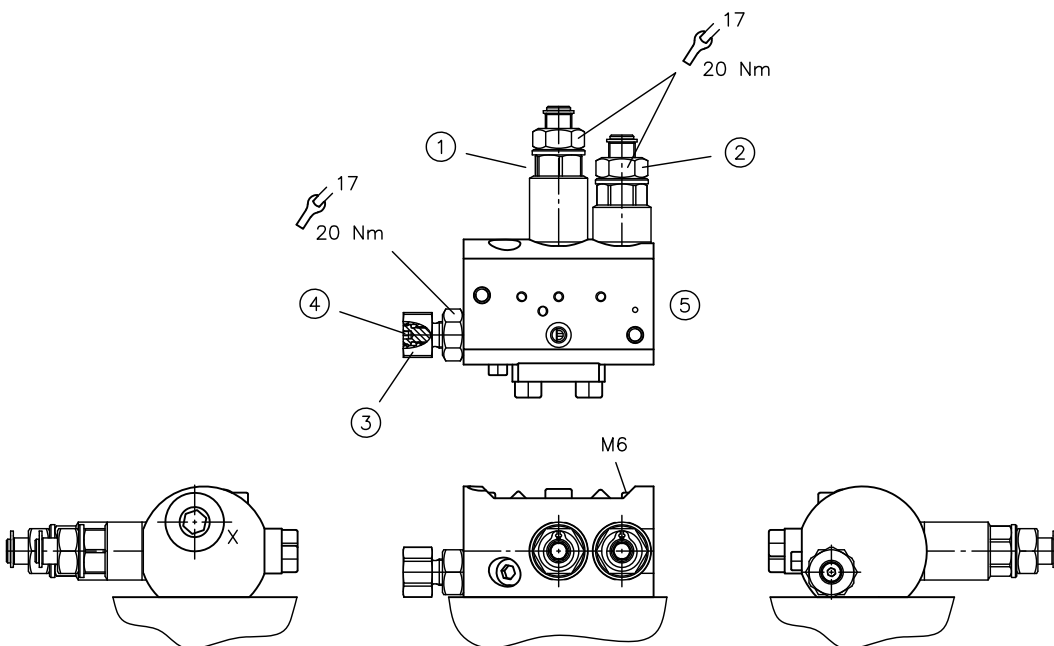

Adjustment range for ① and ② restricted by retaining ring.

- 1 Differential pressure  $\Delta p$  (stand-by pressure)
- 2 Maximum pressure  $p_{max}$  (pressure limitation)
- 3 Return throttle
- 4 Bypass throttle
- 5 X port for LS signal: G 1/4  
Order coding for adapter to 9/16-18 UNF (SAE-6): 7993245.00

**Dynamic throttle**

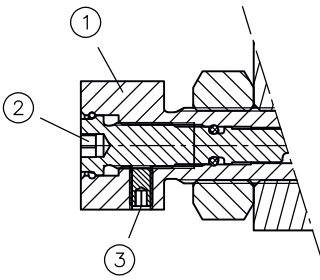

- 1 Return throttle (17-mm hex bolt)
- 2 Bypass throttle (3-mm hex socket)
- 3 Counter screw (1.5-mm hex socket)

**Description of the two-part dynamic screw**

- While the pump is swinging out, the return throttle (outer screw on the two-part dynamic screw) adjusts the on-stroke time from  $V_{g \text{ min}}$  to  $V_{g \text{ max}}$ .
  - Loosening the screw reduces the damping and accelerates the on-stroke time.
  - Adjustment range: Approx. 5.5 rotations/4 mm
- While the pump is swinging in, a bypass throttle (inner screw on the two-part dynamic screw) adjusts the destroke time from  $V_{g \text{ max}}$  to  $V_{g \text{ min}}$ .
  - Loosening the screw increases the damping and slows down the destroke time.
  - Tightening the screw reduces the damping and accelerates the destroke time.
  - Adjustment range: Approx. 4 rotations/2 mm

Pressure adjustment	Pressure range (bar)	$\Delta p$ (bar)/revolution	Factory-set pressure setting (bar)
Maximum pressure $p_{\text{max}}$	20 ... 400	approx. 50	300
Differential pressure $\Delta p$	20 ... 55	approx. 10	27

**⚠ CAUTION**

**Overloading components due to incorrect pressure settings.**

Risk of minor injury. Parts may burst or fly off, and uncontrolled leakage of hydraulic fluid.

- Pay attention to the maximum operating pressure of the pump, valves and fittings.
- Always monitor the pressure gauge when setting and changing the pressure.

## 2.7.3 Flow controller ZV, ZV1 and V

The ZV-, ZV1- and V controllers are electro-proportional flow controllers that generate a variable, speed-dependent flow rate. They adjust the displacement volume of the pump based on an electrical input signal. The resulting flow rate depends on displacement volume and rotation speed.

The required pilot pressure for adjusting the swivel angle is tapped internally. When used in open centre systems with operating pressures of < 25 bar, an external auxiliary pump or a pre-load valve must be provided to ensure reliable adjustment.

ZV controller: V60N-060/090/110, increasing characteristic line

Only possible in combination with a P, Pe or Pe1 coding pressure controller!

ZV1 controller: V60N-060/090/110, decreasing characteristic line

Only possible in combination with a P, Pe or Pe1 coding pressure controller!

V controller: V60N-130, increasing characteristic line

Only possible in combination with a P3, P3e or P3e1 coding pressure controller!

### P/ZV

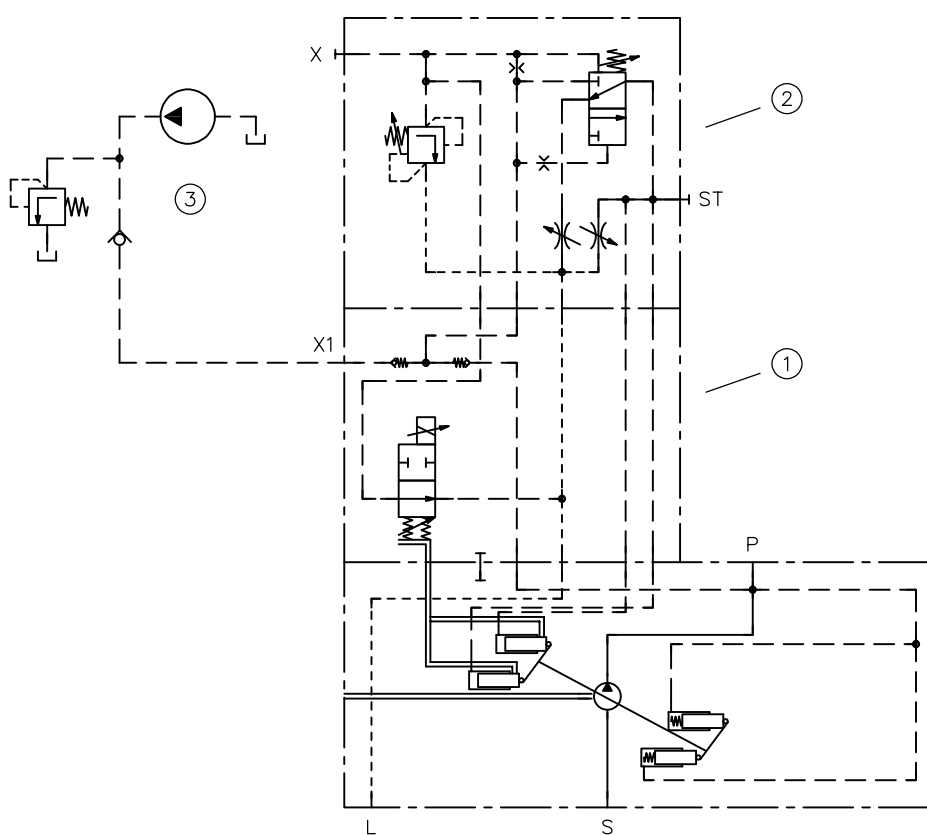

- 1 ZV controller
- 2 P controller
- 3 External auxiliary pump, pressure-limiting valve and check valve (not included)  
Recommended flow rate: 3 - 4 l/min  
Recommended pressure: 40 - 60 bar

**P/ZV1**

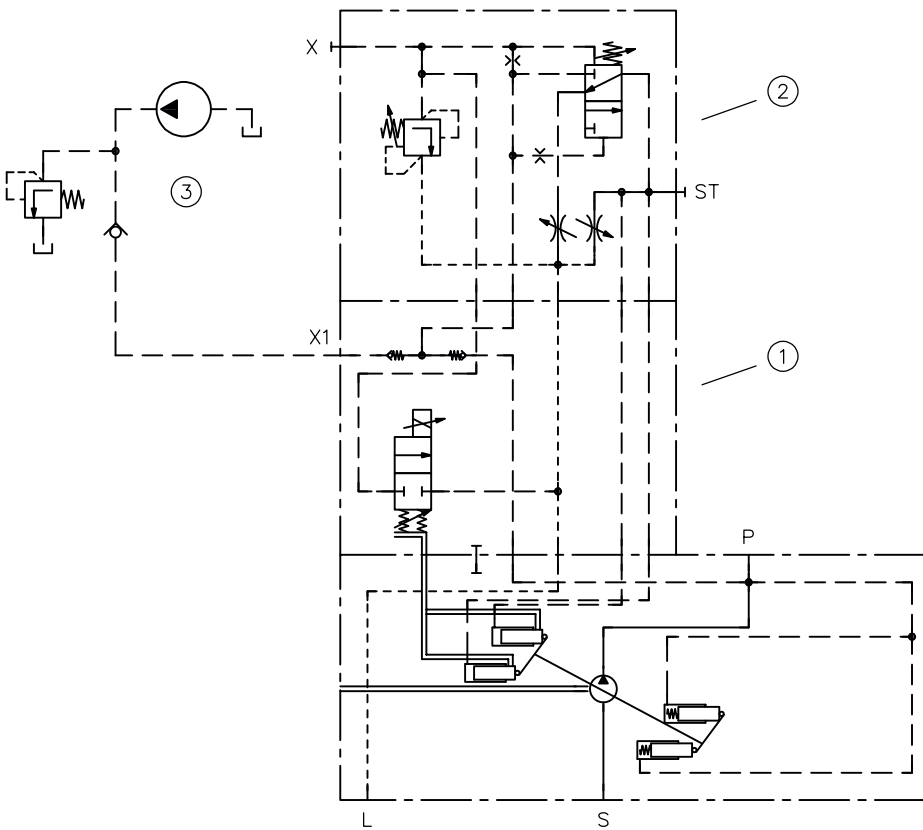

- 1 ZV1 controller
- 2 P controller
- 3 External auxiliary pump, pressure-limiting valve and check valve (not included)  
Recommended flow rate: 3 - 4 l/min  
Recommended pressure: 40 - 60 bar

**P3/V/L**

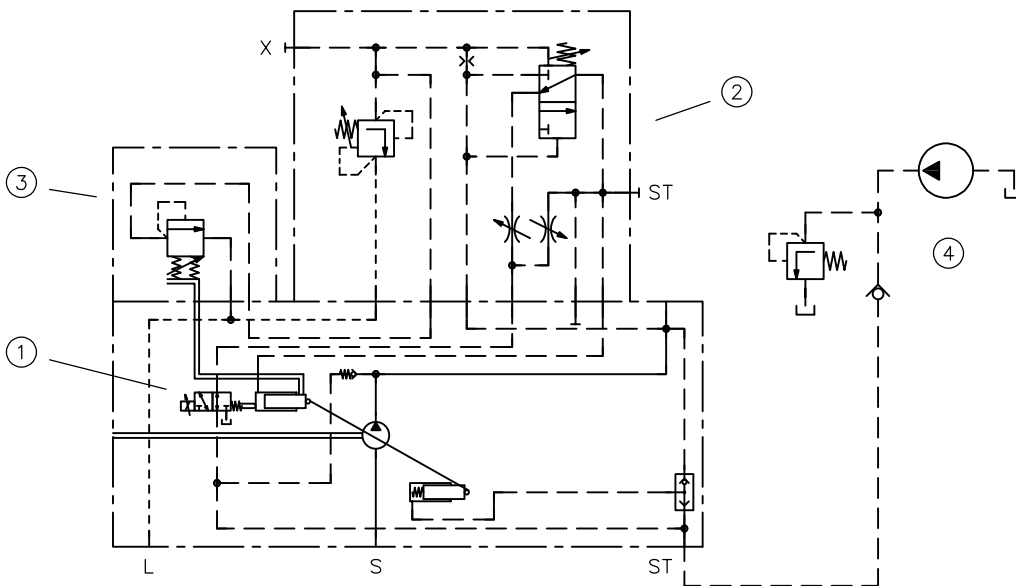

- 1 V controller
- 2 P3 controller
- 3 L controller (installed as standard for V60N-130)
- 4 External auxiliary pump, pressure-limiting valve and check valve (not included in scope of delivery)

**ZV, ZV1**  
Intermediate plates version

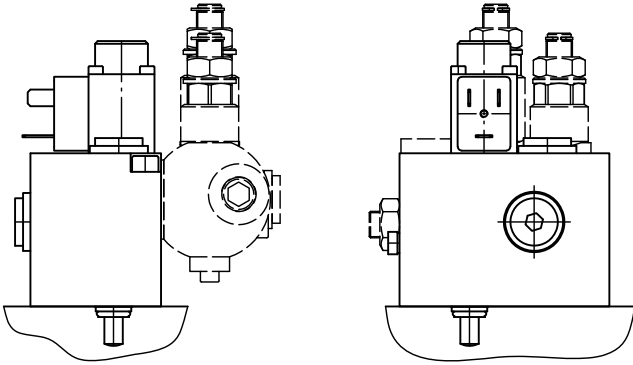

**V**

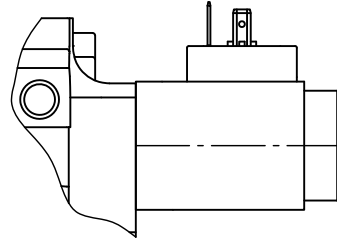

## 2.7.4 Pressure controller P, P3

P and P3 controllers are pressure controllers with fixed pressure setting. As soon as the pump pressure exceeds the set value, they reduce the swivel angle of the pump and regulate a constant pressure level. The pressure setting is adjusted using an adjusting screw on the controller, and, in addition, an external pilot valve can be connected to the X port to enable remote adjustment when necessary.

P and P3 controllers can either be used in constant pressure systems or as a low-loss pressure limitation in combination with an electro-proportional flow controller.

P controller: individual or in combination with type ZV, ZV1, ZL, ZLV1, ZLV or L flow and/or power controller

P3 controller: Only in combination with type V flow controller

**P**

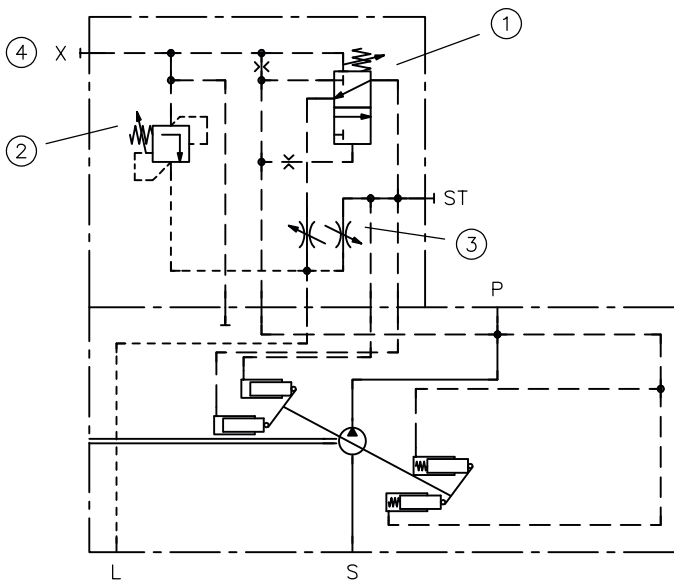

- 1 Main stage
- 2 pilot valve
- 3 Dynamic throttle
- 4 X port for external pilot valve (optional)

**P3/V/L**

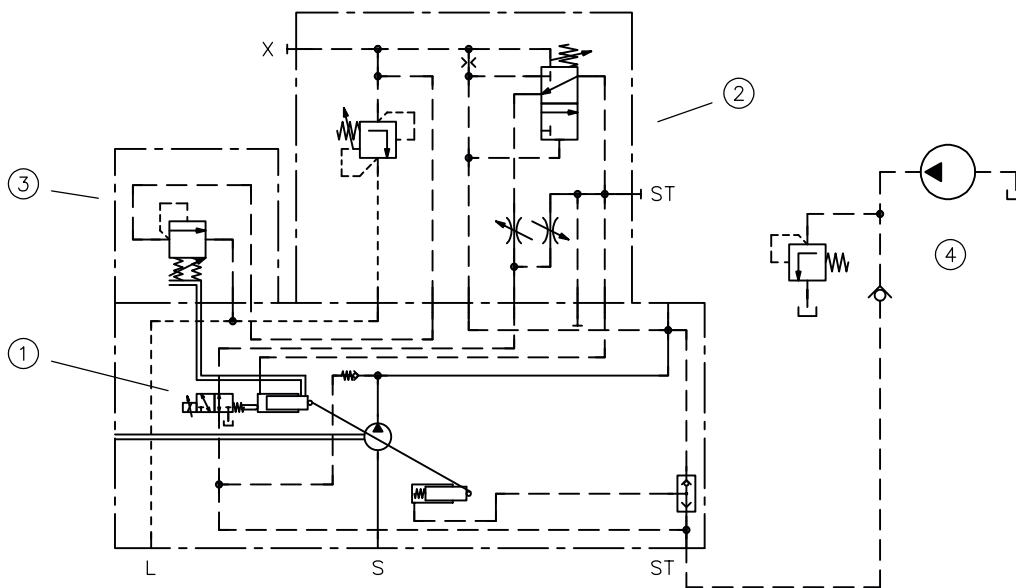

- 1 V controller
- 2 P3 controller
- 3 L controller (installed as standard for V60N-130)
- 4 External auxiliary pump, pressure-limiting valve and check valve (not included in scope of delivery)

**P, P3**

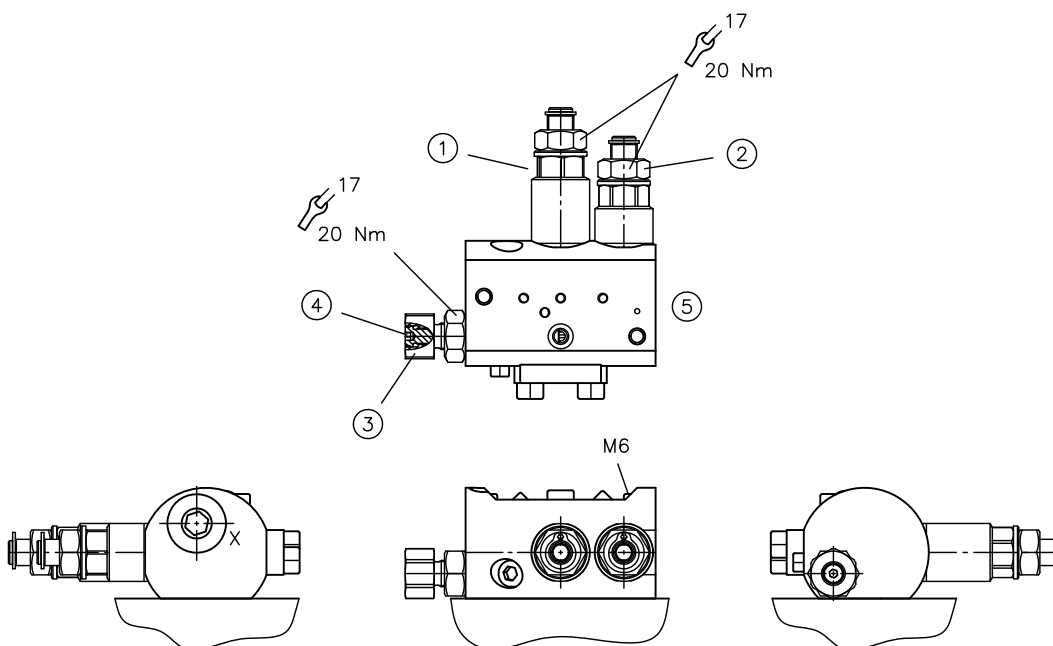

Adjustment range for ① and ② restricted by retaining ring.

- 1 Differential pressure  $\Delta p$  (stand-by pressure)
- 2 Maximum pressure  $p_{max}$  (pressure limitation)
- 3 Return throttle
- 4 Bypass throttle
- 5 X port for LS signal: G 1/4  
Order coding for adapter to 9/16-18 UNF (SAE-6): 7993245.00

**Dynamic throttle**

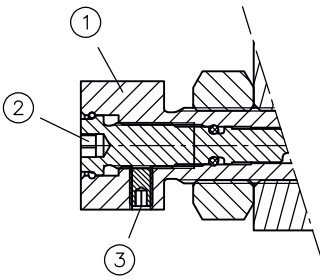

- 1 Return throttle (17-mm hex bolt)
- 2 Bypass throttle (3-mm hex socket)
- 3 Counter screw (1.5-mm hex socket)

**Description of the two-part dynamic screw**

- While the pump is swinging out, the return throttle (outer screw on the two-part dynamic screw) adjusts the on-stroke time from  $V_{g \text{ min}}$  to  $V_{g \text{ max}}$ .
  - Loosening the screw reduces the damping and accelerates the on-stroke time.
  - Adjustment range: Approx. 5.5 rotations/4 mm
- While the pump is swinging in, a bypass throttle (inner screw on the two-part dynamic screw) adjusts the destroke time from  $V_{g \text{ max}}$  to  $V_{g \text{ min}}$ .
  - Loosening the screw increases the damping and slows down the destroke time.
  - Tightening the screw reduces the damping and accelerates the destroke time.
  - Adjustment range: Approx. 4 rotations/2 mm

Pressure adjustment	Pressure range (bar)	$\Delta p$ (bar)/revolution	Factory-set pressure setting (bar)
Maximum pressure $p_{\text{max}}$	20 ... 400	approx. 50	300
Differential pressure $\Delta p$	20 ... 55	approx. 10	27

**⚠ CAUTION**

**Overloading components due to incorrect pressure settings.**

Risk of minor injury. Parts may burst or fly off, and uncontrolled leakage of hydraulic fluid.

- Pay attention to the maximum operating pressure of the pump, valves and fittings.
- Always monitor the pressure gauge when setting and changing the pressure.

## 2.7.5 Pressure controller Pe, Pe1, P3e, P3e1

Pe, Pe1, P3e and P3e1 controllers are electro-proportional pressure controllers. As soon as the pump pressure exceeds the set value, the controller reduces the swivel angle of the pump and regulates a constant pressure level.

The minimum and maximum pressures are set mechanically on the controller. In between these values, the pressure can be adjusted proportionally using an electrical signal.

Pe, P3e controller: Increasing characteristic line, all sizes, cannot be combined with other pump controllers (type ZL or ZV)

Pe1, P3e1 controller: Decreasing characteristic line, only V60N-060/090/110, cannot be combined with other pump controllers (type ZL or ZV)

Pe

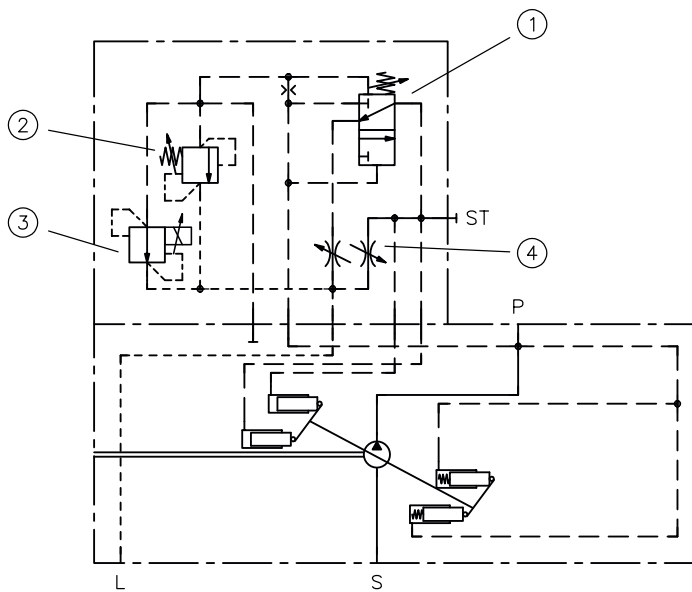

Pe1

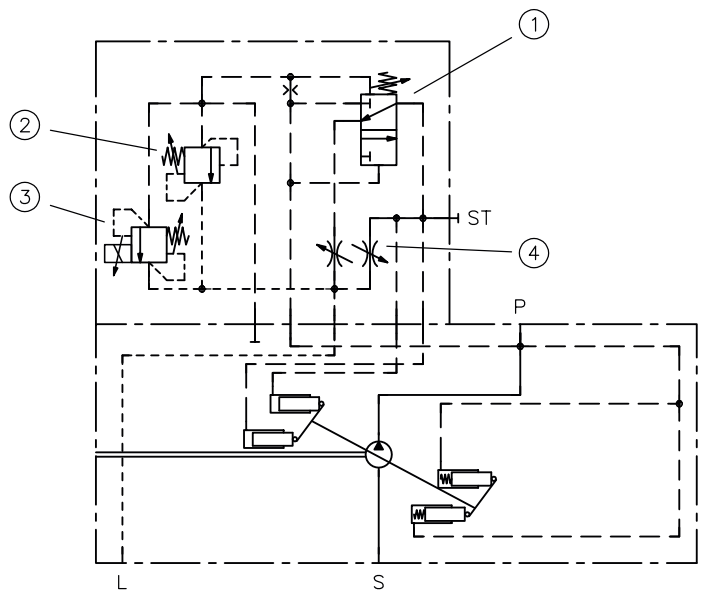

- 1 Minimum pressure setting  $p_{min}$
- 2 Maximum pressure setting  $p_{max}$
- 3 Electro-proportional pressure adjustment
- 4 Dynamic throttle

Pe

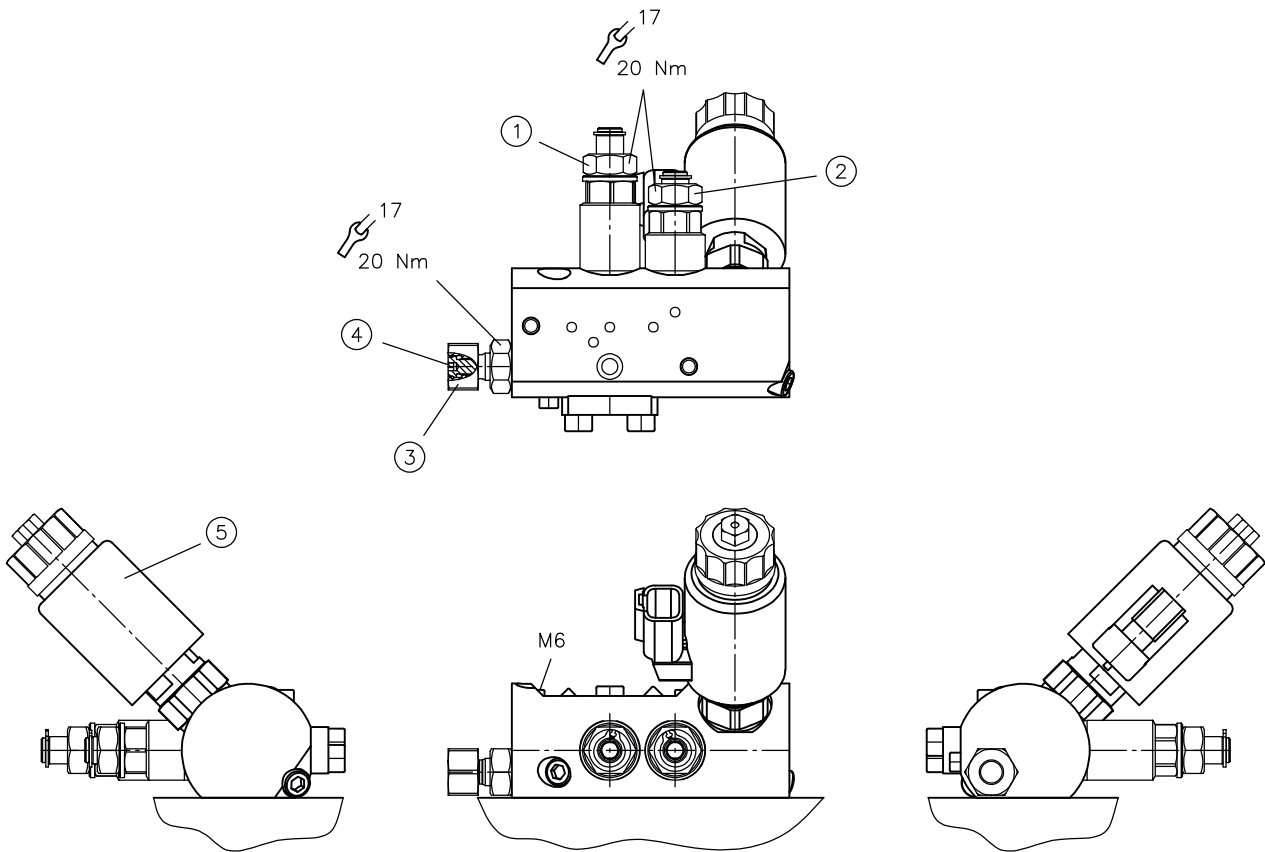

- 1 Differential pressure  $\Delta p$  (stand-by pressure)
- 2 Maximum pressure  $p_{max}$  (pressure limitation)
- 3 Return throttle
- 4 Bypass throttle
- 5 Proportional pressure-limiting valve type PMVE 1 S

Pe1

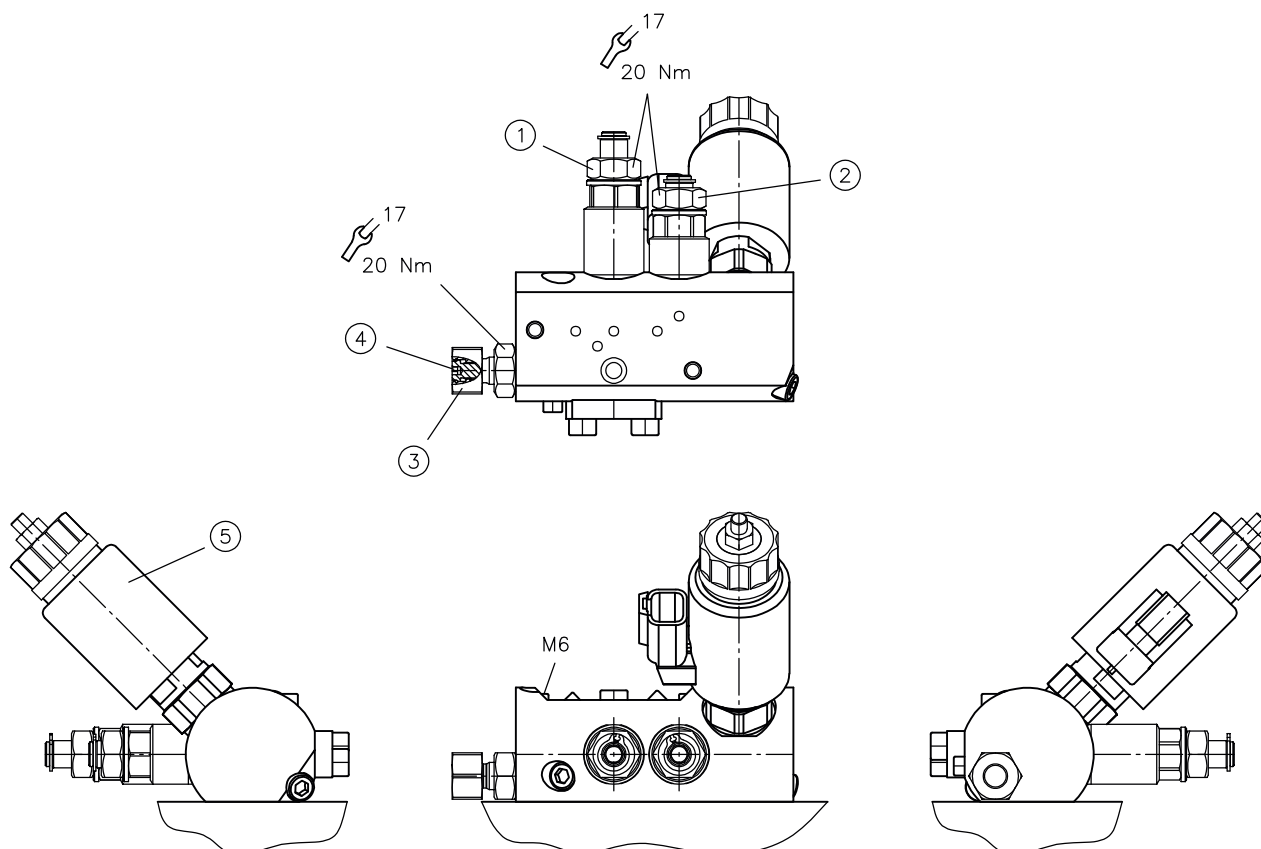

- 1 Differential pressure  $\Delta p$  (stand-by pressure)
- 2 Maximum pressure  $p_{max}$  (pressure limitation)
- 3 Return throttle
- 4 Bypass throttle
- 5 Proportional pressure-limiting valve type PMVE 1 R

Pressure adjustment	Pressure range (bar)	$\Delta p$ (bar)/revolution	Factory-set pressure setting (bar)
Maximum pressure $p_{max}$ (Pe, P3e)	20 to 400	approx. 50	300
Maximum pressure $p_{max}$ (Pe1, P3e1)	20 to 400	approx. 140	300
Minimum pressure $p_{min}$	20 to 55	approx. 10	27

**⚠ CAUTION**

**Overloading components due to incorrect pressure settings.**

Risk of minor injury. Parts may burst or fly off, and uncontrolled leakage of hydraulic fluid.

- Pay attention to the maximum operating pressure of the pump, valves and fittings.
- Always monitor the pressure gauge when setting and changing the pressure.

## 2.7.6 Power controller ZL and L

The ZL and L controllers are power controllers with fixed settings. As soon as the product of displacement volume and pressure exceeds the set value, the controller reduces the swivel angle of the pump to protect the drive shaft, motor or gearbox from overload ( $p_B \times V_g = \text{constant}$ ).

ZL controller: V60N-060/090/110

L controller: V60N-130 (series)

The setting is made either as a torque limitation (Nm) or power limitation (kW) at the corresponding speed ( $\text{min}^{-1}$ ).

Drive torque

$$M = \frac{V_g \cdot \Delta p}{20 \cdot \pi \cdot \eta_{mh}} (\text{Nm})$$

Drive power

$$P = \frac{2\pi \cdot M \cdot n}{60000} = \frac{Q \cdot \Delta p}{600 \cdot \eta_t} (\text{kW})$$

$V_g$  = Geometric output volume ( $\text{cm}^3/\text{rev}$ )

$\Delta p$  = Differential pressure

$n$  = Speed ( $\text{min}^{-1}$ )

$\eta_v$  = Volumetric efficiency

$\eta_{mh}$  = Mechanical-hydraulic efficiency

$\eta_T$  = Overall efficiency  $\eta_T = \eta_v \cdot \eta_{mh}$

$Q$  = Flow rate (l/min)

$M$  = Torque (Nm)

$P$  = Power (kW)

LSP/ZL

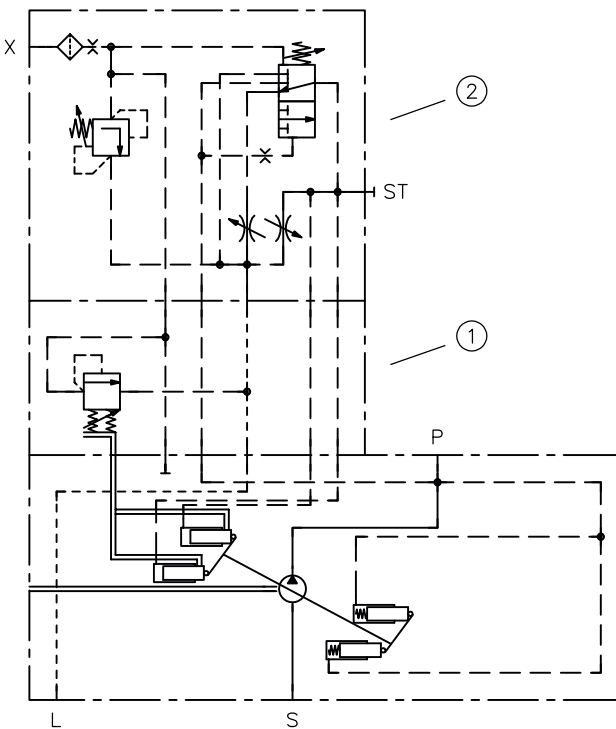

- 1 ZL controller
- 2 LSP controller

LSP/L

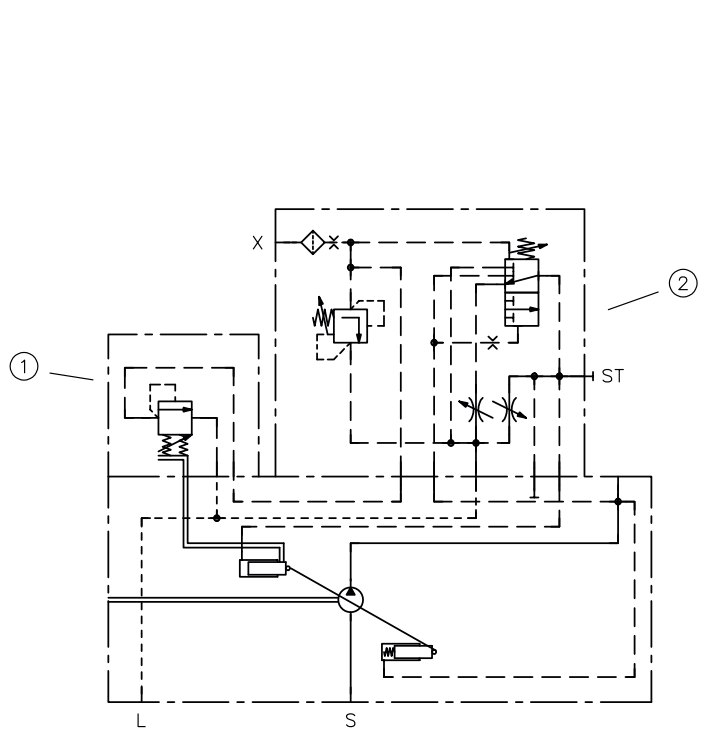

**ZL**  
Intermediate plates version

**L**

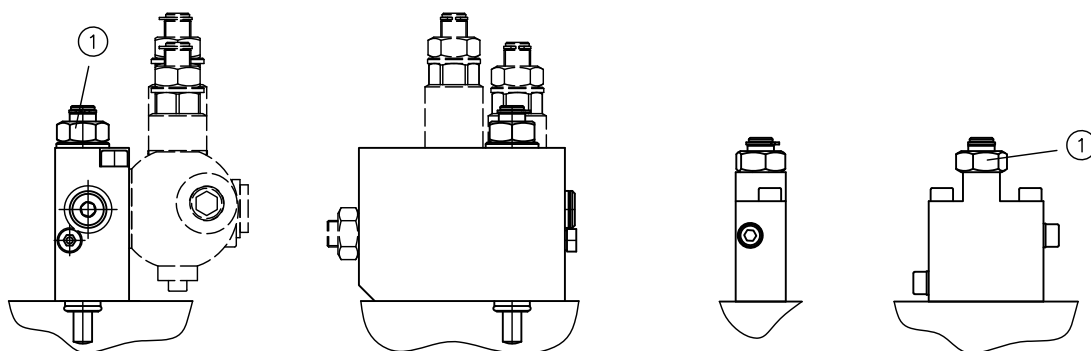

1 Torque setting

**Torque setting**

	$\Delta M$ (Nm)/revolution	Factory-set torque setting (Nm)	Adjustment range
Power controller ZL	approx. 190	200	25 to 100% of $N_{m_{max}}$
Power controller L	approx. 190	700	200 to 700 Nm

## 2.7.7 ZLV and ZLV1 combined power and flow controller

ZLV and ZLV1 controllers combine a ZL power controller and the ZV, ZV1 flow controllers. Both functions are merged in an intermediate plate and the P pressure controller is flange-mounted in the same way as for the separate controllers.

These combined controllers are only available for sizes V60N-060 and V60N-090.

**ZLV**

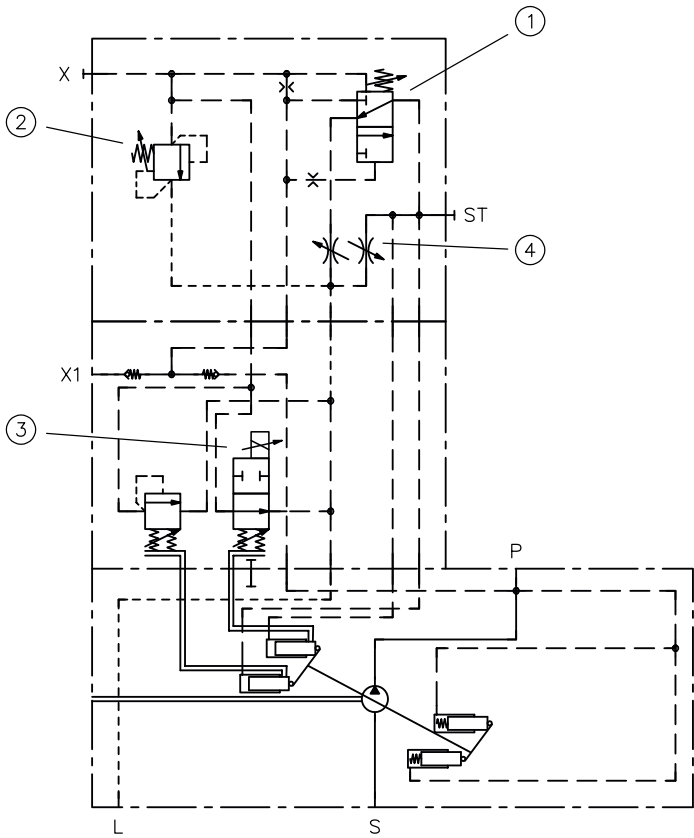

**ZLV1**

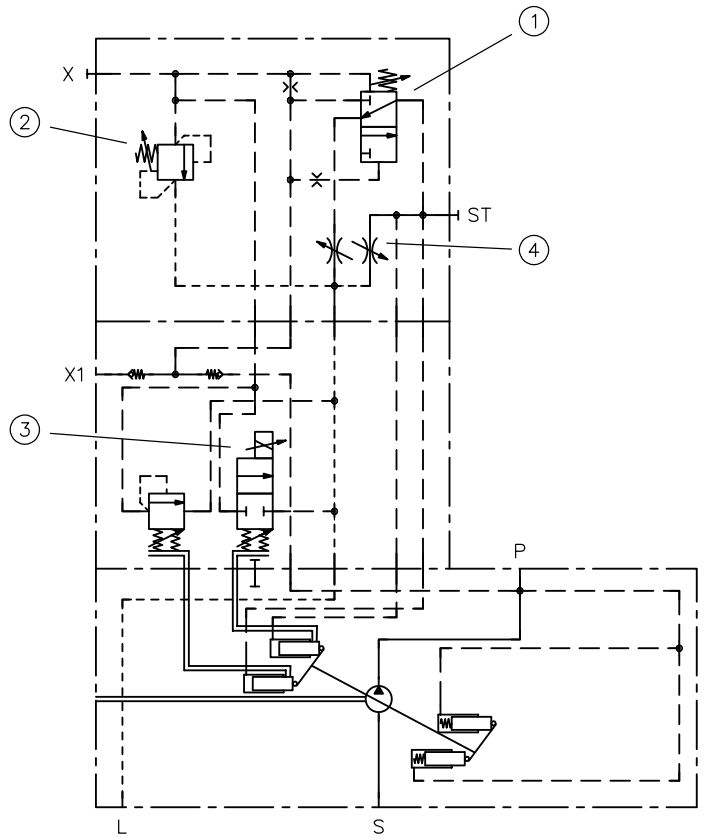

- 1 Minimum pressure setting  $p_{min}$
- 2 Maximum pressure setting  $p_{max}$
- 3 Electro-proportional pressure adjustment
- 4 Dynamic throttle

ZLV, ZLV1

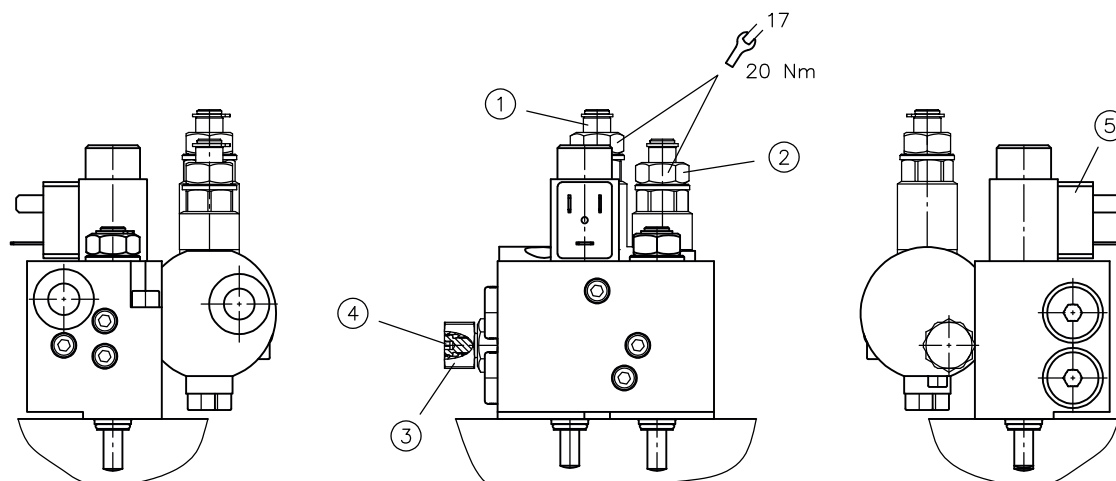

- 1 Differential pressure  $\Delta p$  (stand-by pressure)
- 2 Maximum pressure  $p_{max}$  (pressure limitation)
- 3 Return throttle
- 4 Bypass throttle
- 5 Electro-proportional pressure adjustment

### 2.7.8 ZW intermediate plate

The ZW intermediate plate is a 45° spacer plate. For V60N-060/090/110, it is required for housing versions with radial connections (coding 2 and 3) to avoid a collision between the pump controller and the suction or pressure line.

/ZW

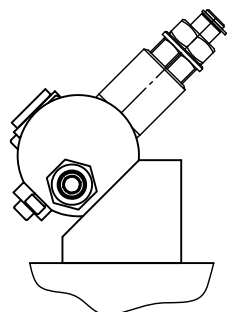

## 2.8 Stroke limitation

Coding	Description
2	Stroke limitation adjustable
2/...	Stroke limitation fixed with specification of displacement volume $V_g$ (cm <sup>3</sup> /rev)

## 2.9 Thread type

Coding	Connections
Without coding	DIN EN ISO 228-1
UNF	SAE J 514

## 2.10 Flange version (output side)

### Ordering example:

V60N-110 RDYN-2-0-01/LSP-350-A00/76- C 022

Coding V60N			Flange	Shaft
060	090/110	130		
C 001	C 002	C 003	Prepared for thru-shaft, sealed with cap	
C 010	--	C 030	DIN ISO 7653	DIN ISO 14
C 011	C 021	C 031	SAE-A 2-Loch J 744 82-2 DIN ISO 3019-1	SAE-A J 744 (16-4 DIN ISO 3019-1) 9T 16/32 DP
C 012	C 022	C 032	SAE-A 2-Loch J 744 82-2 DIN ISO 3019-1	SAE-A J 744 (16-4 DIN ISO 3019-1) * 9T 16/32 DP *
C 013	--	--	SAE-A 2-Loch J 744 82-2 DIN ISO 3019-1	19-4 DIN ISO 3019-1 11T 16/32 DP
C 014	C 024	C 034	SAE-B 2-Loch J 744 101-2 DIN ISO 3019-1	SAE-B J 744 (22-4 DIN ISO 3019-1) 13T 16/32 DP
--	C 026	C 036	SAE-B 2-Loch J 744 101-2 DIN ISO 3019-1	SAE-BB J 744 (25-4 DIN ISO 3019-1) 15T 16/32 DP
C 015	C 025	C 035	SAE-B 4-Loch J 744 101-4 DIN ISO 3019-1	SAE-B J 744 (22-4 DIN ISO 3019-1) 13T 16/32 DP
--	C 027	C 037	SAE-C 2-Loch J 744 127-2 DIN ISO 3019-1	SAE-C J 744 (32-4 DIN ISO 3019-1) 14T 12/24 DP
--	C 028	C 038	SAE-C 4-Loch J 744 127-4 DIN ISO 3019-1	SAE-C J 744 (32-4 DIN ISO 3019-1) 14T 12/24 DP
--	C 125	C 135	SAE-B 4-Loch J 744 101-4 DIN ISO 3019-1	SAE-BB J 744 (25-4 DIN ISO 3019-1) 15T 16/32 DP

\* ANSI B 92.1, FLAT ROOT SIDE FIT spline width deviating from standard,  $s = 2.357 - 0.03$

### ! NOTICE

Pay attention to the maximum permissible weight torque and drive torque, as the flange or shaft may be damaged otherwise.

### ! NOTICE

- An additional support is to be provided for pump combinations.
- Additional versions on request.

## 2.11 Solenoid voltage and connector

Coding	Electrical connection	Nominal voltage	Protection class (IEC 60529)
G 12 G 24	DIN EN 175 301-803A	12 V DC 24 V DC	IP 65
AMP 12 APM 24	AMP Junior Timer	12 V DC 24 V DC	IP 65
DT 12 DT 24	German (DT 04-2P)	12 V DC 24 V DC	IP 67

## 3 Parameters

### 3.1 General data

<b>Designation</b>	Variable displacement axial piston pump		
<b>Pump version</b>	Axial piston pump according to the swash plate principle		
<b>Mounting</b>	Mounting flange according to DIN ISO 7652, DIN ISO 3019-1 or DIN ISO 3019-2		
<b>Surface</b>	primed RAL 7043		
<b>Drive/output torque</b>	max. permissible drive/output torque (Nm)		
	<b>Nominal size</b>		
	<b>060</b>	<b>090 / 110 series 03</b>	<b>110 series 04 / 130</b>
<b>Parallel key splined shaft D</b>	530/100	800/600	800/700
<b>Spline shaft M</b>	--	530/530	--
<b>Spline shaft H</b>	210/100	--	--
<b>Spline shaft U</b>	210/100	--	--
<b>Spline shaft T</b>	340/100	--	--
<b>Spline shaft S</b>	530/100	640/600	640/640
<b>Spline shaft Q</b>	--	900/600	900/700
<b>Installation position</b>	any Installation information see Chapter 5, "Installation, operation and maintenance information"		
<b>Rotation direction</b>	<ul style="list-style-type: none"> <li>▪ right</li> <li>▪ left</li> </ul>		
<b>Change of rotating direction</b>	<b>V60N-060/-090/-110 series 03:</b> Turn the end plate of the pump (see dimension diagram) and replace the port plate; see also <a href="#">Assembly instructions for variable displacement axial piston pump type V60N: B 7960 N</a>		
<b>Ports/connections</b>	<ul style="list-style-type: none"> <li>▪ Suction port</li> <li>▪ Pressure connection</li> <li>▪ Drain port</li> <li>▪ Pressure gauge connection</li> <li>▪ LS port</li> </ul>		
<b>Hydraulic fluid</b>	Hydraulic fluid, according to DIN 51524 Parts 1 to 3; ISO VG 10 to 68 according to DIN ISO 3448 Viscosity range: 10 - 1000 mm <sup>2</sup> /s Optimal operating range: approx. 16 - 60 mm <sup>2</sup> /s see restrictions during cold-start and warm-up phase Also suitable for biologically degradable hydraulic fluids type HEPG (polyalkylene glycol) and HEES (synthetic ester) at operating temperatures up to approx. +70°C.		
<b>Cleanliness level</b>	<b>ISO 4406</b> <u>19/17/14</u>		

### Temperatures

Environment: approx. -40 to +60 °C, hydraulic fluid: -25 to +80 °C, pay attention to the viscosity range. Start temperature: down to -40 °C is permissible (take account of the start viscosities!), as long as the steady-state temperature is at least 20 K higher during subsequent operation. Biologically degradable hydraulic fluids: note manufacturer specifications. With consideration for the seal compatibility, not above +70°C.

### Designation

		Nominal size			
		060	090	110	130
Max. swash plate angle		20.5°	21.5°	21.5°	21.5°
Absolute inlet pressure required in open circuit	bar	0.85	0.85	0.85	0.85
Max. permissible housing pressure (static/dynamic)	bar	2/3	2/3	2/3	2/3
Max. permissible inlet pressure (static/dynamic)	bar	20/30	20/30	20/30	20/30
Max. speed during suction operation and max. swash plate angle at 1 bar abs. Inlet pressure	min <sup>-1</sup>	2500	2300	2200	2100
Max. speed with zero stroke and 1 bar abs. Inlet pressure	min <sup>-1</sup>	3000	3000	3000	3000
Min. speed in continuous operation	min <sup>-1</sup>	500	500	500	500
Required drive torque at 100 bar	Nm	100	151	184	230
Drive power at 250 bar and 2000 rpm	kW	53	79.5	97.2	120
Weight torque	Nm	30	35.5	40	40
Inertia torque	kg m <sup>2</sup>	0.005	0.008	0.01	0.011
Noise level at 250 bar, 1500 min <sup>-1</sup> and max. swash plate angle (measured in acoustic measurement chamber according to DIN ISO 4412-1 with measuring distance 1 m)	dB(A)	75	75	75	75

#### ! NOTICE

The minimum operating pressure in the pump line depends on the speed and the swivel angle; the pressure must not fall below 15 bar under any circumstances.

#### ! NOTICE

The housing pressure is only allowed to be 1 bar higher than the suction pressure.

## 3.2 Weight

Coding	Without controller	With controller				
		LSP, LSPT, P, P3	ZL	ZW	Pe, Pe1, P3e, P3e1	ZV, ZV1
060	23 kg	+ 1.0 kg	+ 1.0 kg	+ 0.7 kg	+ 1.5 kg	+ 1.9 kg
090	26 kg	+ 1.0 kg	+ 1.0 kg	+ 0.7 kg	+ 1.5 kg	+ 1.9 kg
110-03	29 kg	+ 1.0 kg	+ 1.0 kg	+ 0.7 kg	+ 1.5 kg	+ 1.9 kg
110-04 / 130	27.3 kg	+ 1.0 kg	+ 1.0 kg	--	+ 1.5 kg	--

### 3.3 Pressure and delivery flow

Operating pressure see Chapter 2.1, "Basic type and nominal size"

displacement volume see Chapter 2.1, "Basic type and nominal size"

### 3.4 Characteristic lines

#### 3.4.1 Basic pump

##### Delivery flow and power

The diagram shows delivery flow and drive power over pressure without a controller at 1500 min<sup>-1</sup>.

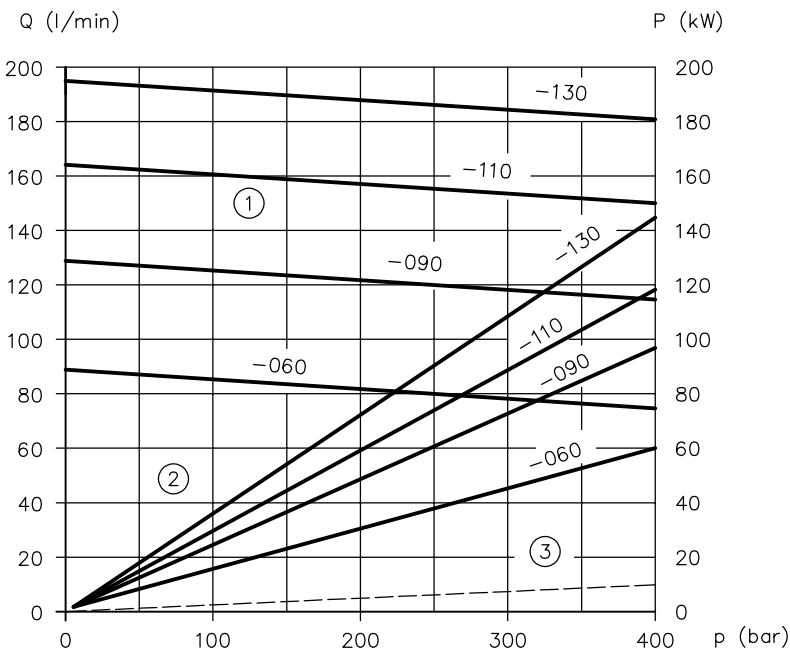

$p$  pressure (bar);  $Q$  delivery flow (l/min);  $P$  power (kW)

- 1 Delivery flow/pressure
- 2 Drive power/pressure (max. swash plate angle)
- 3 Drive power/pressure (zero stroke)

### Inlet pressure and self-suction speed

The diagram shows the inlet pressure / rotation speed at max. swash plate angle and an oil viscosity of 75 mm<sup>2</sup>/s.

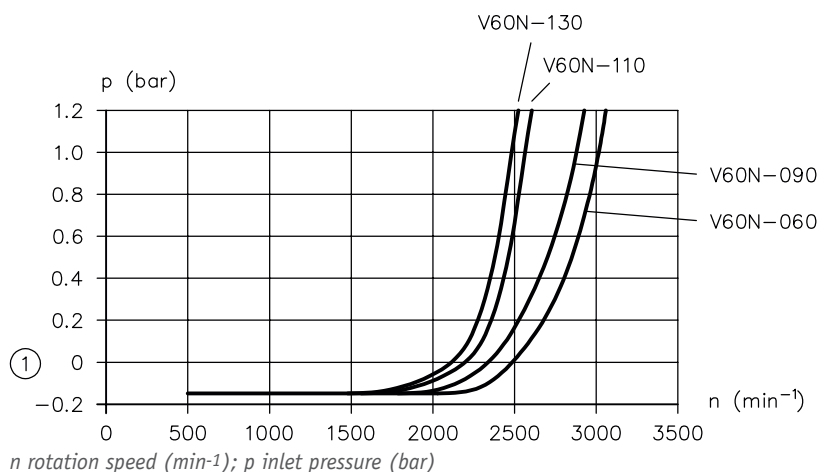

1 0 bar relative = 1 bar absolute

### Acting times

#### Acting times T1 (LSP and LSPT controllers)

The diagram shows the on-stroke time depending on the pressure for the LSP-, LSPT controller, i.e. the time required to swing out the pump and to adjust the displacement volume from the minimum to the maximum.

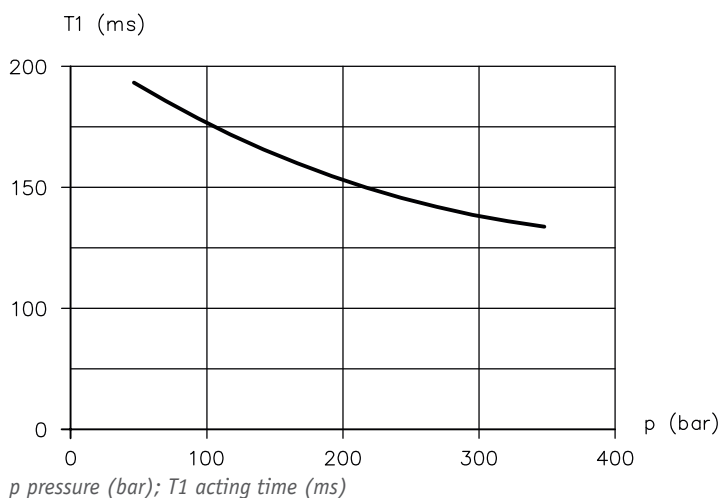

#### Acting times T2 (LSP and LSPT controllers)

The diagram shows the destroke time depending on the pressure for the LSP-, LSPT controller, i.e. the time required to swing in the pump and to adjust the displacement volume from the maximum to the minimum.

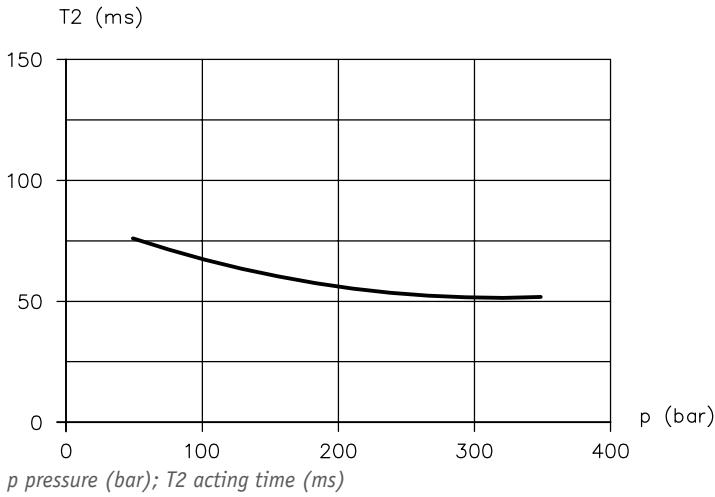

### Acting times $T_u$ , $T_1$ and $T_2$

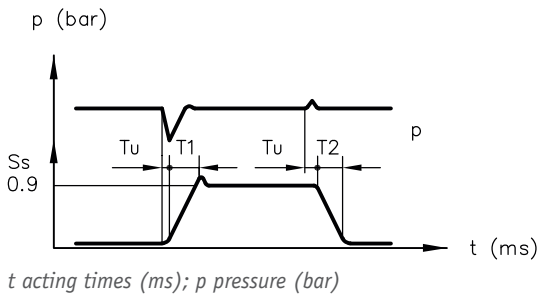

- $S_s$  Positioning travel of actuator
- $T_u$  Delay < 3 ms
- $T_1$  On-stroke time
- $T_2$  Destroke time
- $p$  Pressure

## 3.4.2 Controllers

### Load-sensing controller LSP, LSPT

#### LSP, LSPT

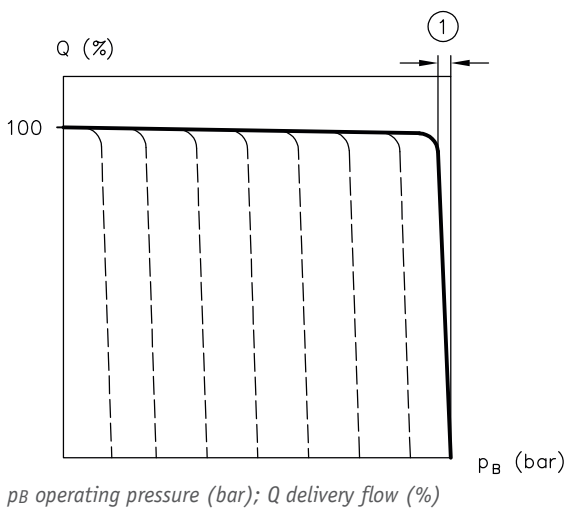

- 1 Approx. 4 bar

**Flow controller QP, ZV, ZV1, V**

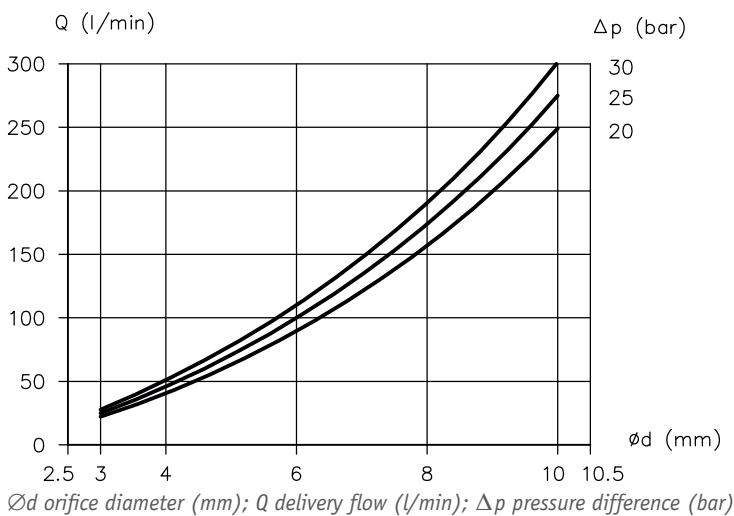

**Determination of the flow rate**

$$Q = 0,55 \cdot d^2 \sqrt{\Delta p}$$

**ZV**

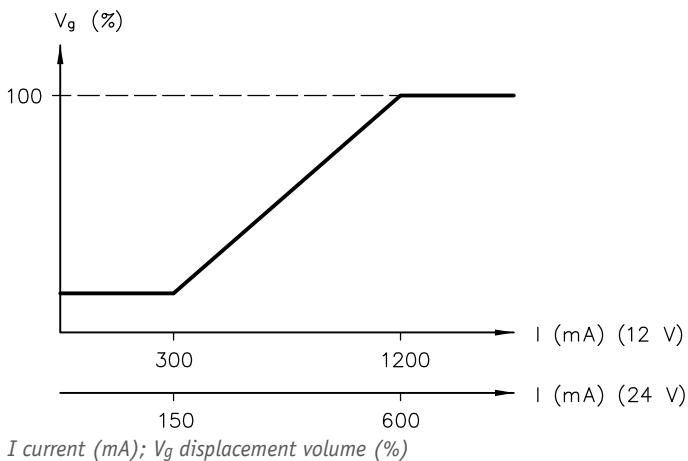

**ZV1**

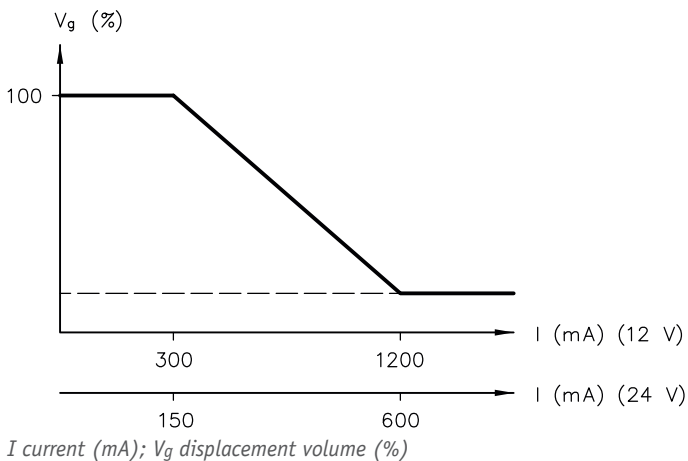

**i INFORMATION**

$V_g = 0 \text{ cm}^3/\text{rev}$  possible through the use of an auxiliary pump.

At  $V_g = 0 \text{ cm}^3/\text{rev}$  flushing via the drain port is also required to guarantee sufficient lubrication of the pump. Recommended flow rate: 3 l/min.

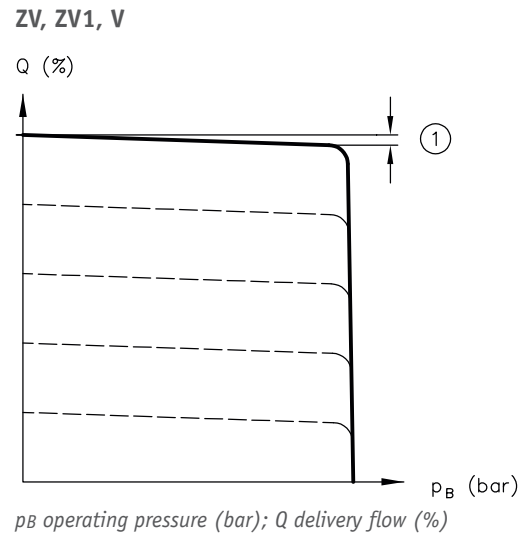
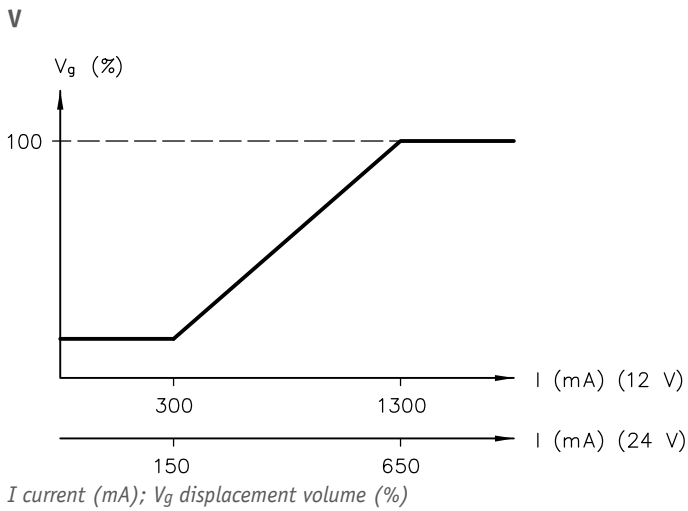

1 Approx. 5%

**i INFORMATION**

$V_g = 0$  cm<sup>3</sup>/rev possible through the use of an auxiliary pump.

At  $V_g = 0$  cm<sup>3</sup>/rev flushing via the drain port is also required to guarantee sufficient lubrication of the pump. Recommended flow rate: 3 l/min.

**Pressure controller P, P3, Pe, Pe1**

**P, P3**

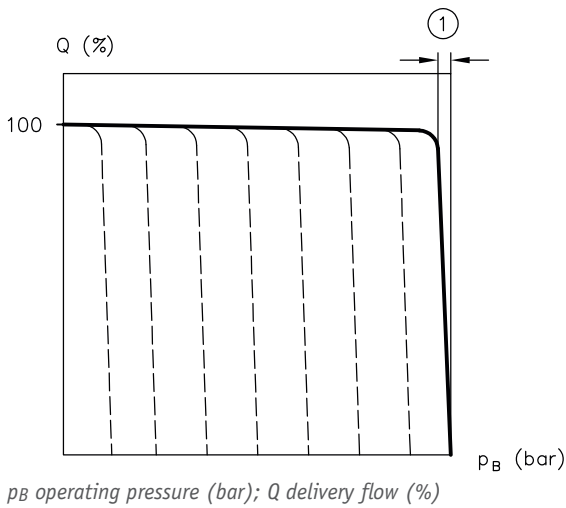

1 Approx. 4 bar

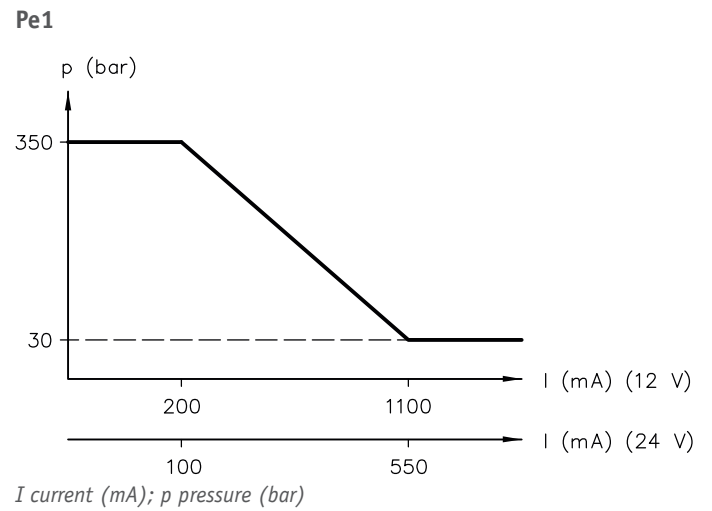
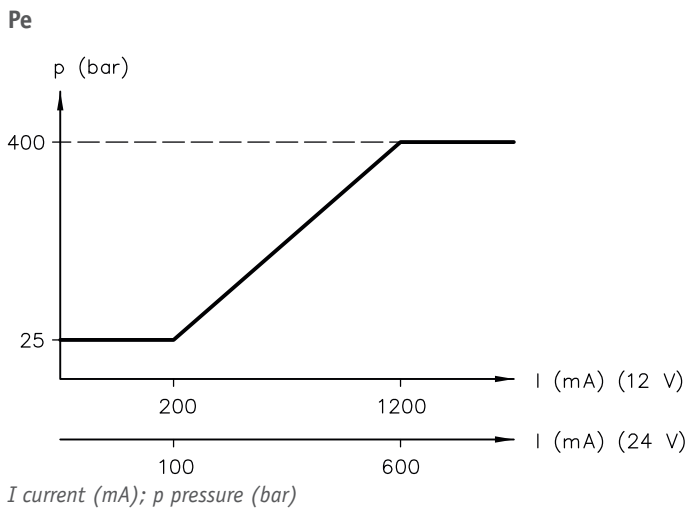

**Pe, Pe1**

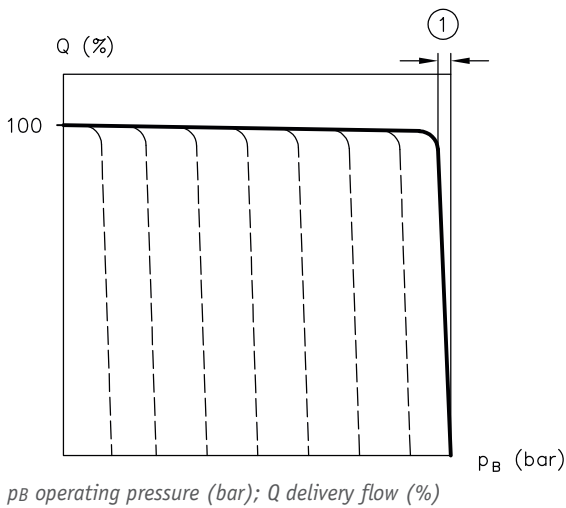

1 Approx. 4 bar

**Power controller ZL, L**

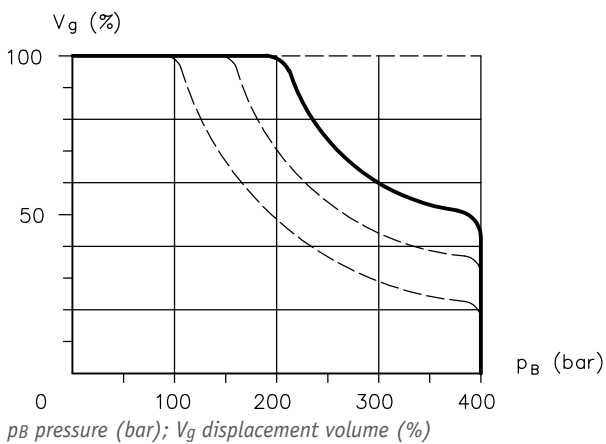

### 3.5 Electrical data

#### Controller coding Pe, Pe1, P3e, P3e1

Nominal voltage	12 V DC	24 V DC
Resistance R <sub>20</sub>	5.5 Ω	22 Ω
Current, cold I <sub>20</sub>	2.2 A	1.1 A
Limit current I <sub>G</sub>	1.28 A	0.64 A
Cooling power P <sub>20</sub>	26 W	26 W
Limit power P <sub>G</sub>	15 W	15 W
Cut-off energy W <sub>A</sub>	≤ 0.3 Ws	≤ 0.3 Ws
Duty cycle	S1 (100%)	
Dither frequency	100 to 200 Hz (recommended value: 100 Hz)	
Dither amplitude $A_D(\%) = \frac{I_{Peak-Peak}}{I_G} \cdot 100$	10% ≤ A <sub>D</sub> ≤ 30% (recommended value 20%)	

#### Controller coding ZV, ZV1

Nominal voltage	12 V DC	24 V DC
Resistance R <sub>20</sub>	5.9 Ω	24 Ω
Current, cold I <sub>20</sub>	2.0 A	1.0 A
Limit current I <sub>G</sub>	1.26 A	0.63 A
Limit power P <sub>G</sub>	14.1 W	14.1 W
Duty cycle	S1 (100 %)	
Dither frequency	210 Hz	
Dither amplitude $A_D(\%) = \frac{I_{Peak-Peak}}{I_G} \cdot 100$	0 % ≤ A <sub>D</sub> ≤ 20 %	

#### Controller coding V

Nominal voltage	12 V DC	24 V DC
Resistance R <sub>20</sub>	7 Ω	24 Ω
Current, cold I <sub>20</sub>	1.7 A	1.0 A
Limit current I <sub>G</sub>	1.3 A	0.7 A
Limit power P <sub>G</sub>	17.7 W	17.8 W
Duty cycle	S1 (100 %)	
Dither frequency	60 - 110 Hz	
Dither amplitude $A_D(\%) = \frac{I_{Peak-Peak}}{I_G} \cdot 100$	20 % ≤ A <sub>D</sub> ≤ 40 %	

**Electrical connection**

**G 12, G 24**

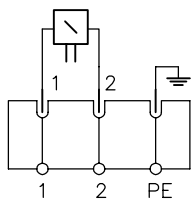

**AMP 12, AMP 24**

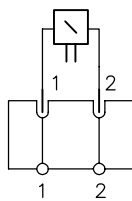

**DT 12, DT 24**

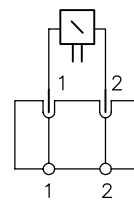

**G .., X .., L .. (WG ..)**



**AMP ..**

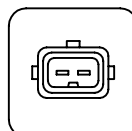

**DT ..**



## 4 Dimensions

All dimensions in mm, subject to change.

### 4.1 Basic pump

#### 4.1.1 Type V60N-060

Rotation direction **clockwise** (viewed from shaft journal)

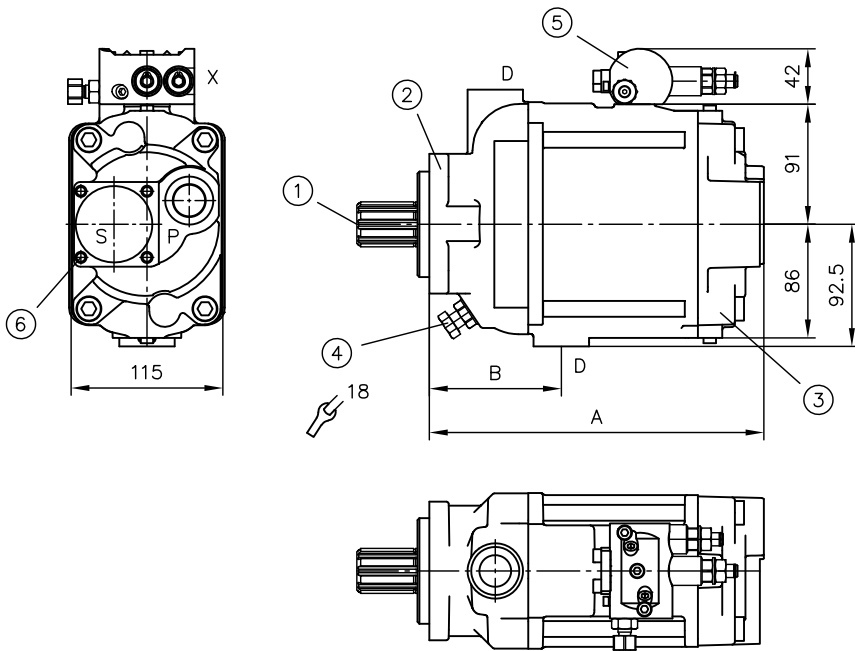

Rotation direction **anti-clockwise** (viewed from shaft journal)

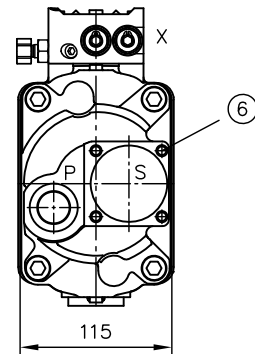

- 1 Shaft journal
- 2 Flange version Y
- 3 Thru-shaft
- 4 Stroke limitation (9 cm<sup>3</sup>/rev.)
- 5 Controller and intermediate plate see Chapter 4.2, "Controllers and intermediate plates"
- 6 Attachment kit for suction intake see Chapter 6.1.1, "Suction intake" (included)

Flange version	Thru-shaft	A	B
Y	-1	253.5	100.0
F, Z, X	-1	249.8	96.3
Y	-2, -3	292.0	100.0
F, Z, X	-2, -3	288.3	96.3

#### Ports P, S and D (ISO 228-1)

P	Pressure port G 3/4
S	Flange suction port
D	Drain port G 3/4
X	G 1/4

#### For coding UNF connections SAE J 514

P	Pressure connection 1 1/16-12 UN-2B
S	Flange suction port
D	Drain port 1 1/16-12 UN-2B
X	G 1/4 (ISO 228-1) with adapter to 7/16-20 (SAE-4)

**Shaft journal**

**Parallel key splined shaft**

Coding D

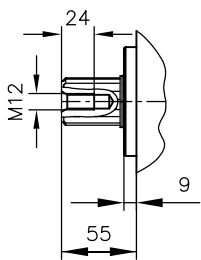

**Spline shaft**

Coding S

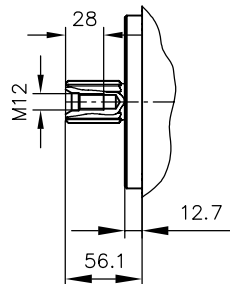

Coding T

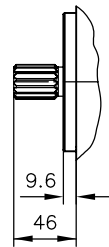

Coding H

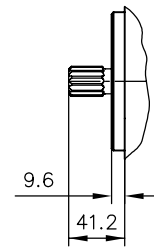

Coding U

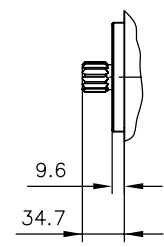

**Flange version (input side)**

Coding Y

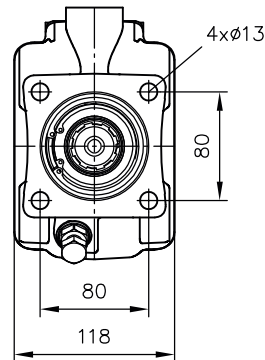
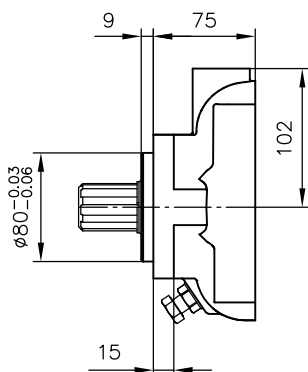

Coding F

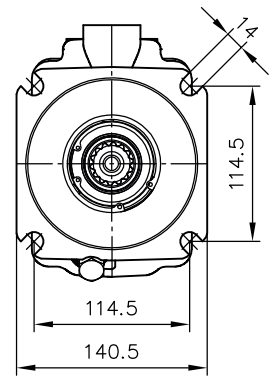
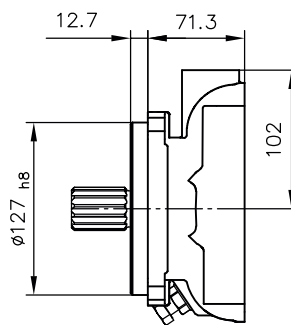

1 Bleeding G 1/8

Coding Z

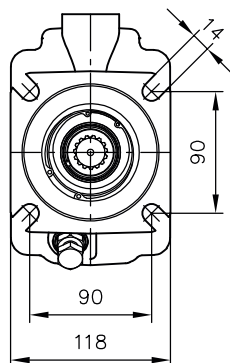
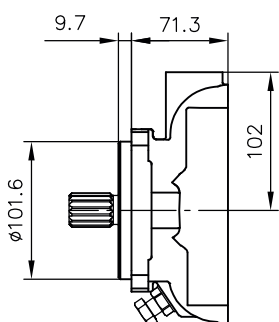

Coding X

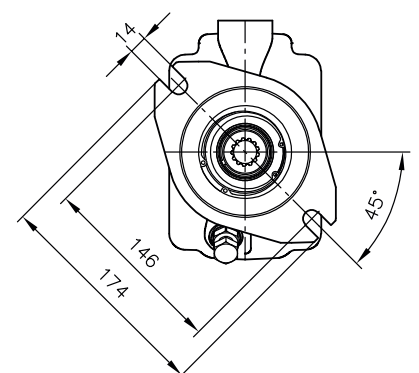
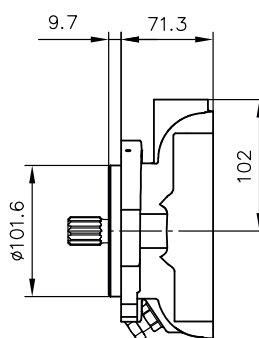

1 Bleeding G 1/8

**Thru-shaft**

**Housing version (axial ports)**

V60N-060 ...-1

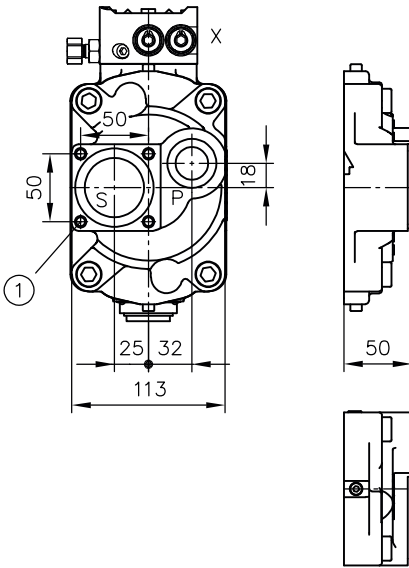

1 Attachment kit for suction intake see Chapter 6.1.1, "Suction intake" (included)

**Housing version (radial ports, with thru-shaft)**

V60N-060 ...-2

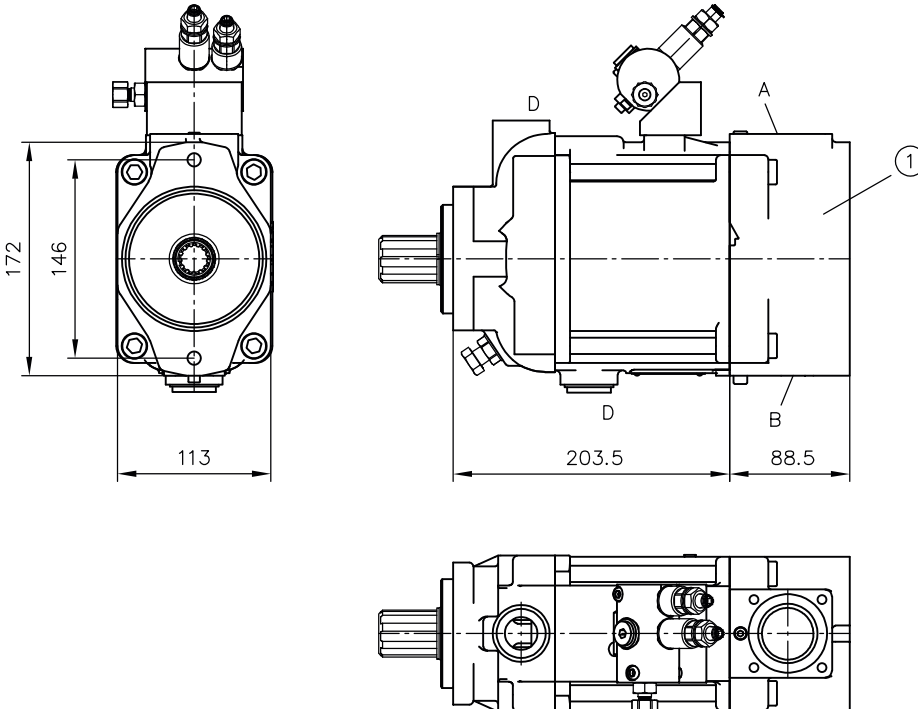

1 Flange version (output side)

**Rotation direction clockwise**

A = suction port

B = pressure connection

**Rotation direction anti-clockwise**

A = pressure connection

B = suction port

Housing version (radial ports)

V60N-060 ...-3

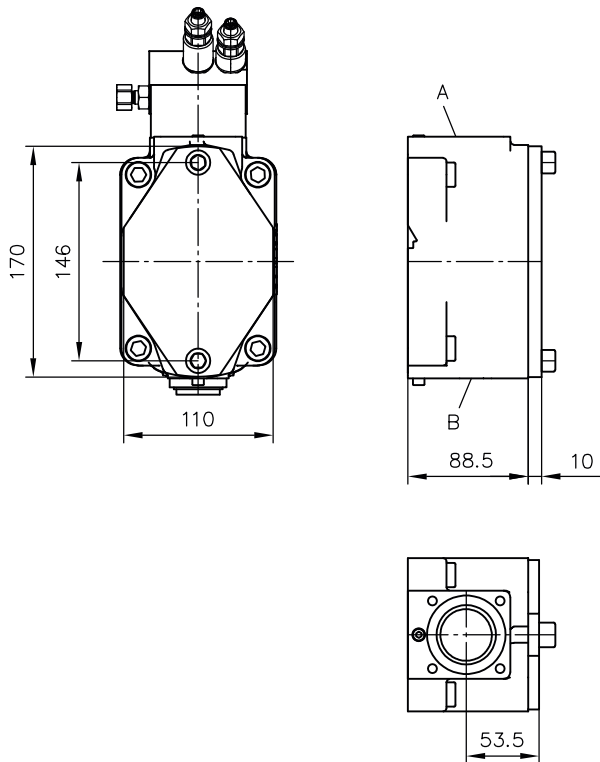

**Rotation direction clockwise**

A = suction port

B = pressure connection

**Rotation direction anti-clockwise**

A = pressure connection

B = suction port

**Flange version (output side)**

Coding **C 010**

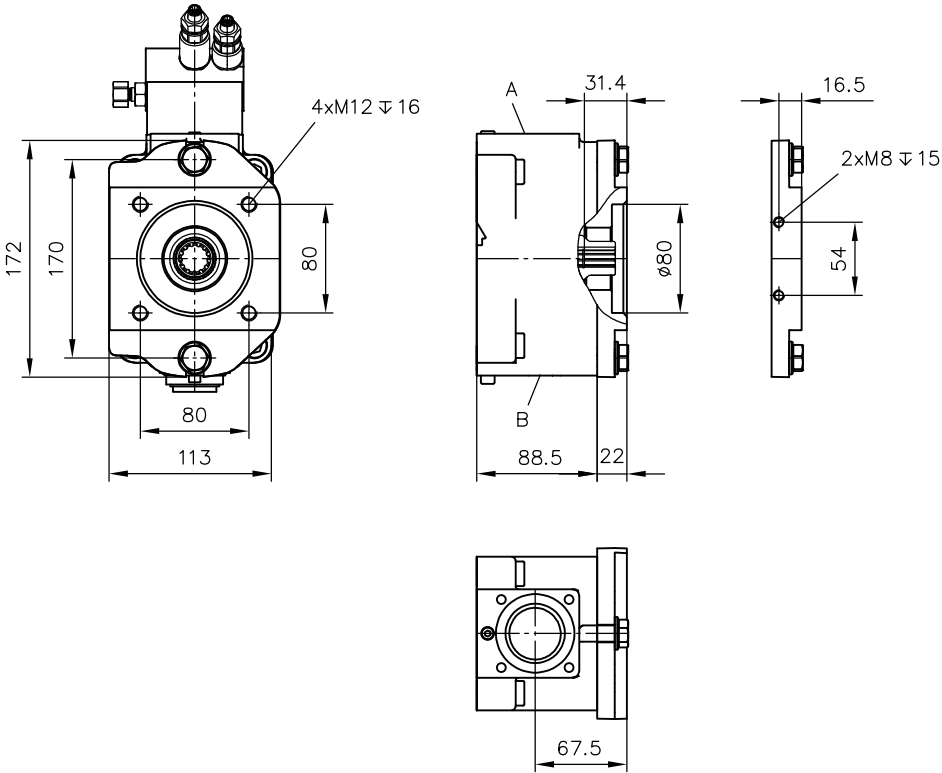

Coding **C 011, C 012**

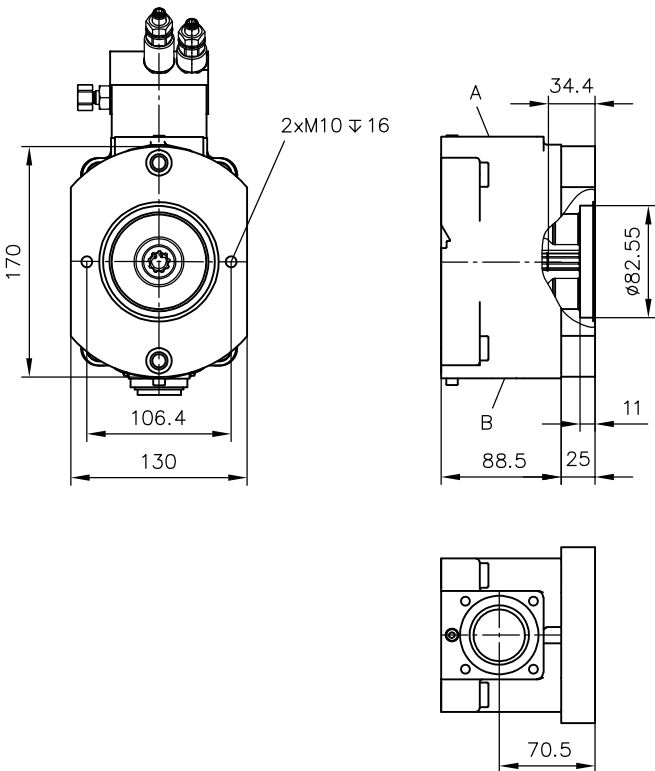

Coding C 014

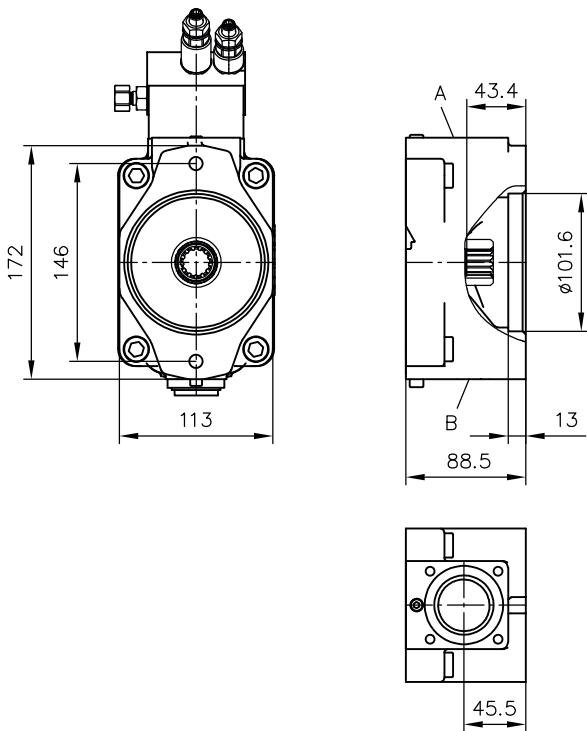

Coding C 015

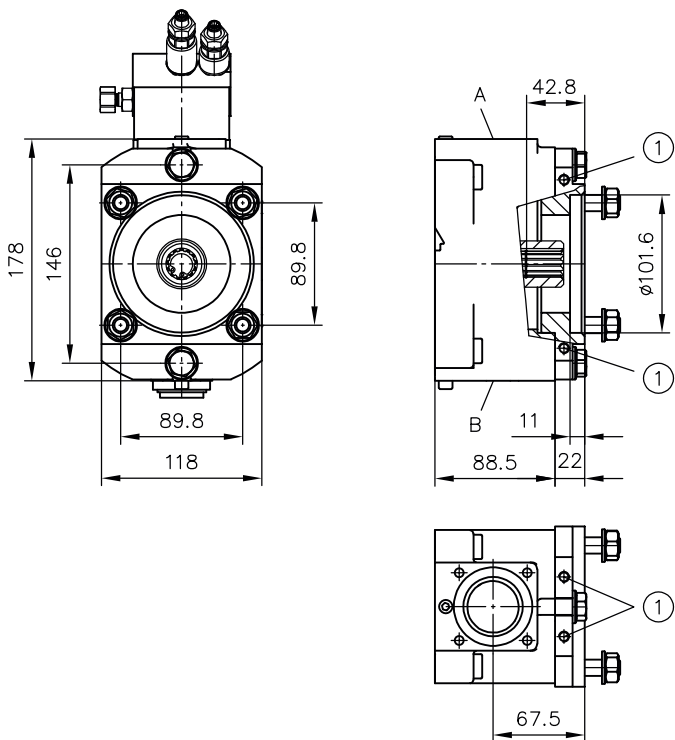

1 Support 8xM8



**Shaft journal**

**Parallel key splined shaft**

Coding D

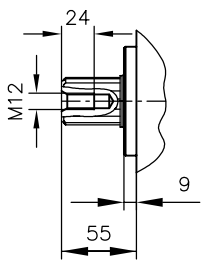

**Spline shaft**

Coding S

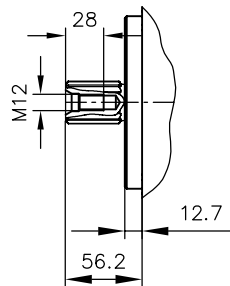

Coding M

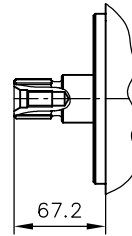

Coding Q

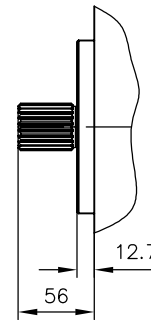

**Flange versions (input side)**

Coding Y

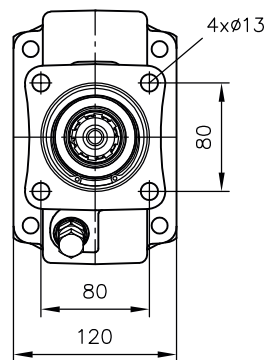
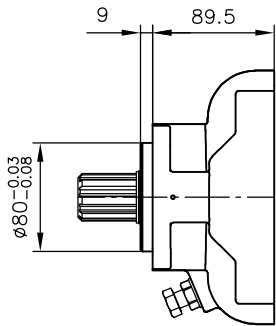

Coding F

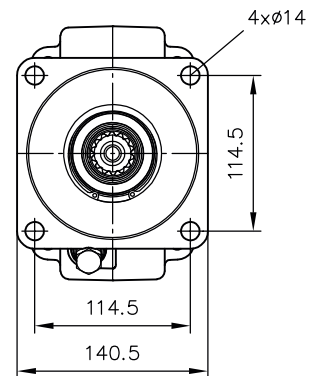
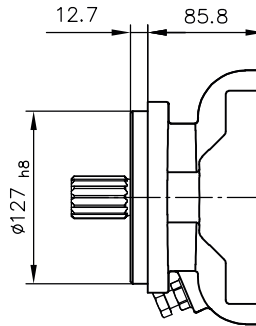

Coding G

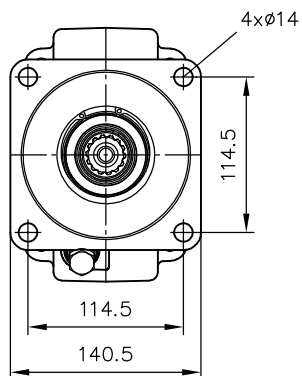
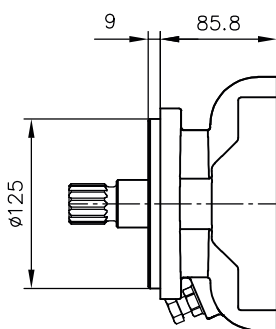

**Thru-shaft**

**Housing version (axial ports)**

V60N-090 ...-1

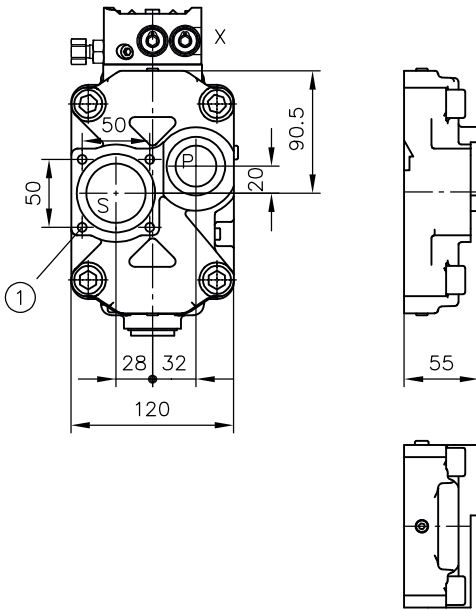

1 Attachment kit for suction intake see Chapter 6.1.1, "Suction intake" (included)

**Housing version (radial ports, with thru-shaft)**

V60N-090 ...-2

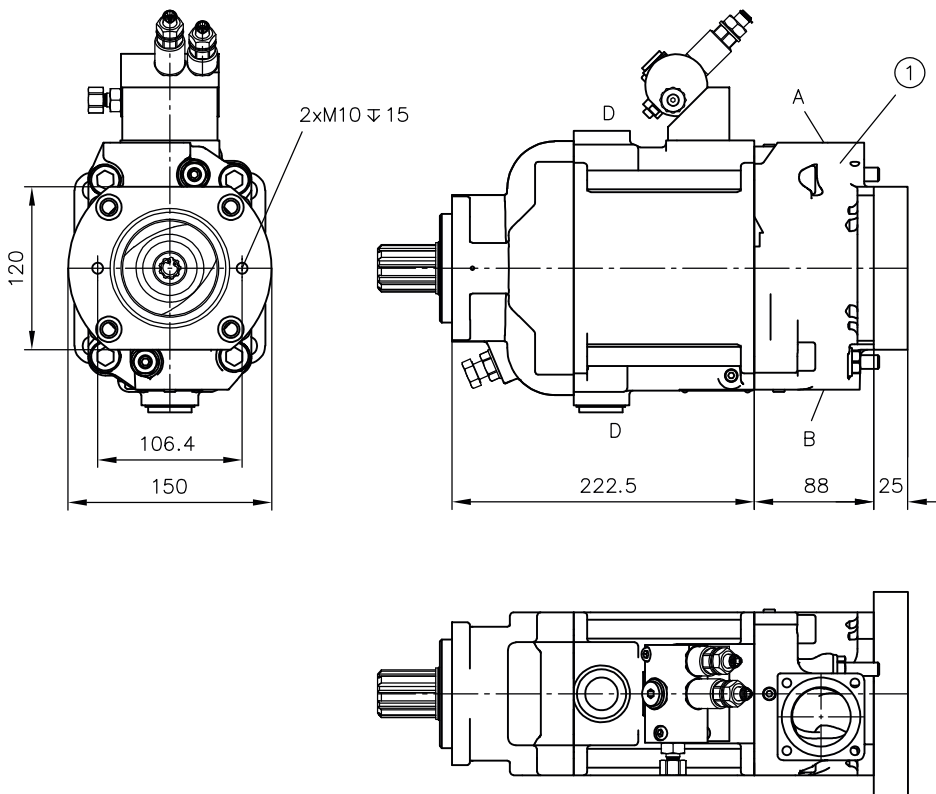

1 Flange version (output side)

**Rotation direction clockwise**

A = suction port

B = pressure connection

**Rotation direction anti-clockwise**

A = pressure connection

B = suction port

Housing version (radial ports)

V60N-090 ...-3

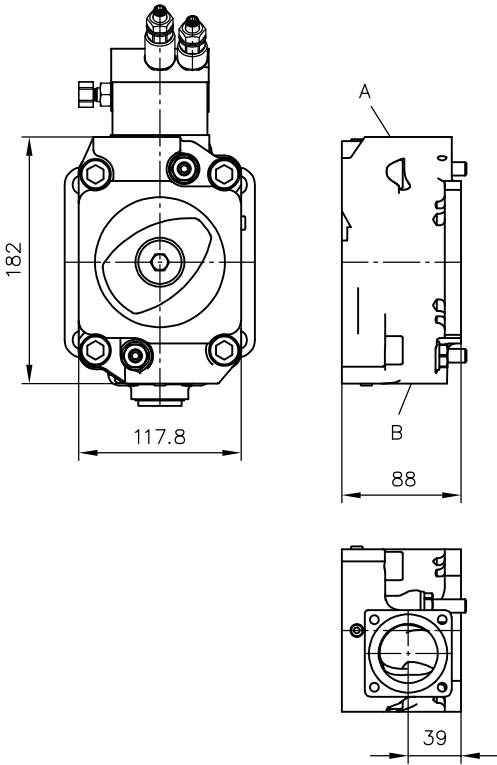

Rotation direction clockwise

A = suction port

B = pressure connection

Rotation direction anti-clockwise

A = pressure connection

B = suction port

Housing version (axial ports, ports SAE J 518)

V60N-090 ...-4

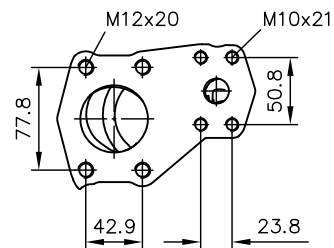
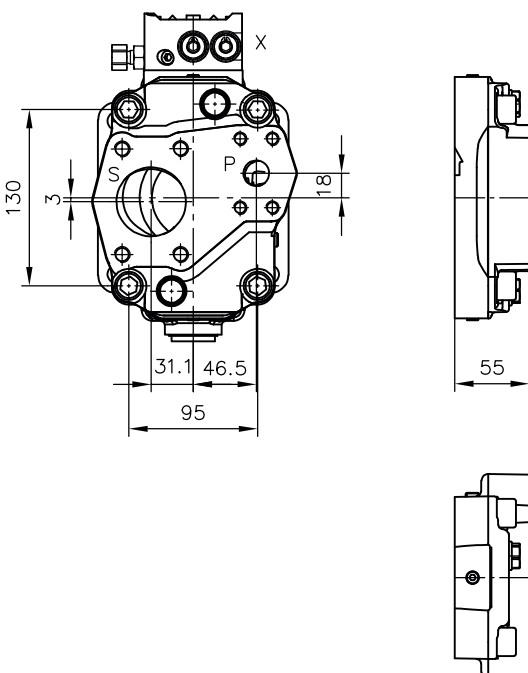

Ports (SAE J 518)

P	Pressure connection SAE 3/4" (6000 psi)
S	Suction port SAE 2" (3000 psi)

**Flange versions (output side)**

Coding C 021, C 022

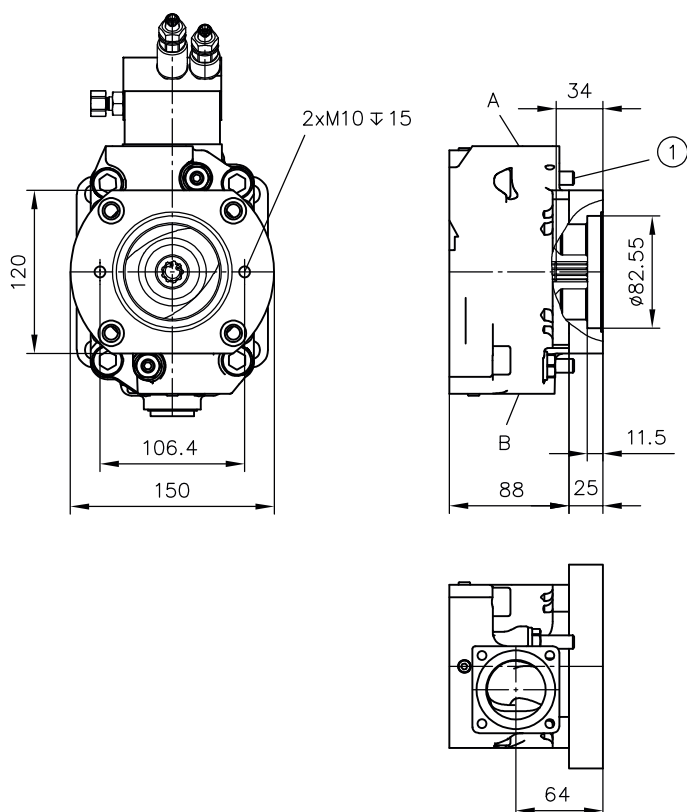

1 Stroke limitation

Coding C 024, C 026

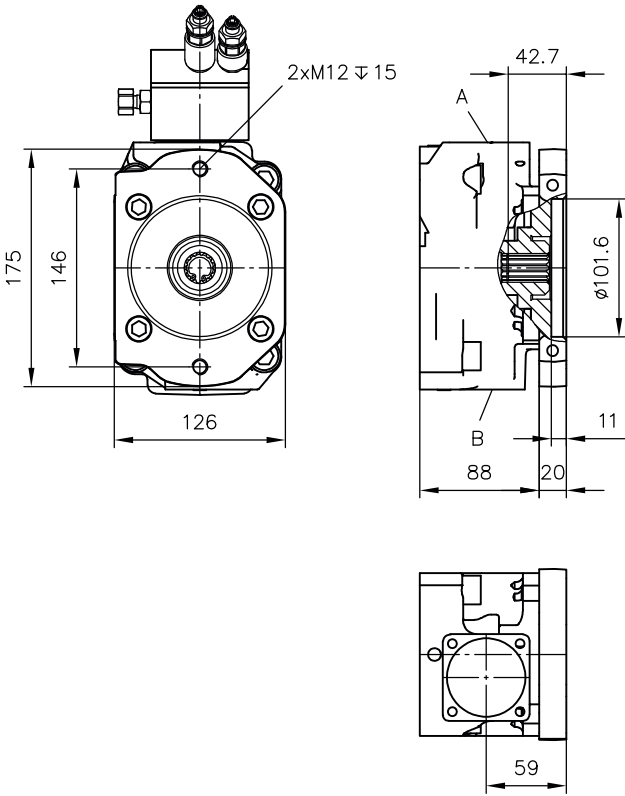

Coding C 025

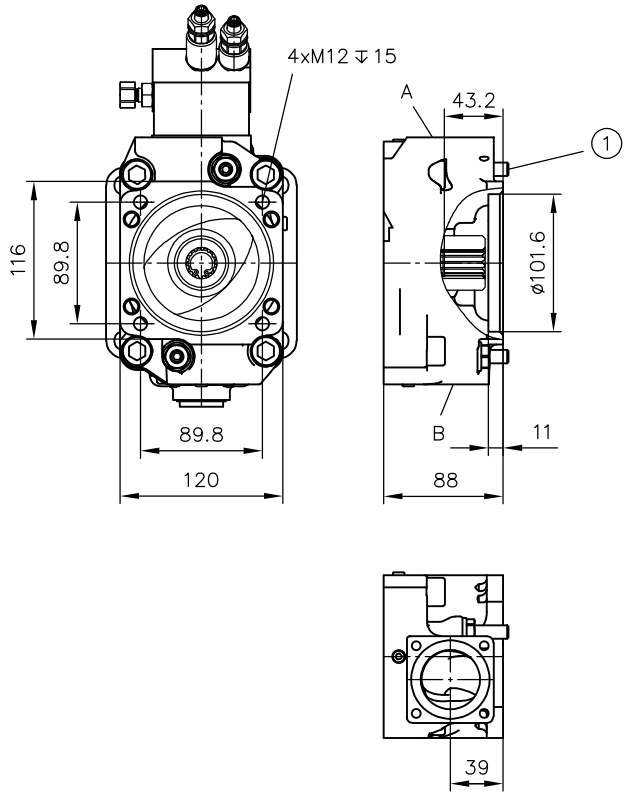

1 Stroke limitation

Coding C 027

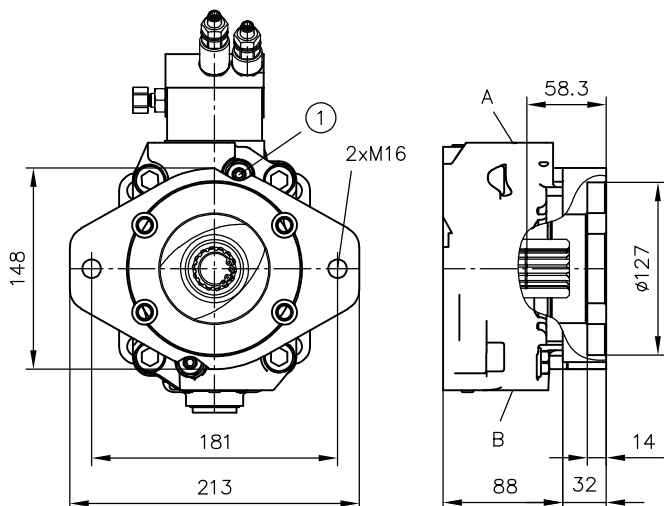

Coding C 028

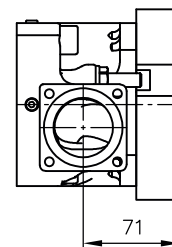
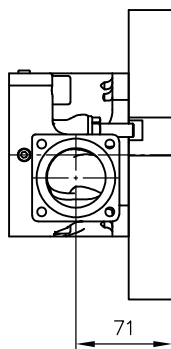
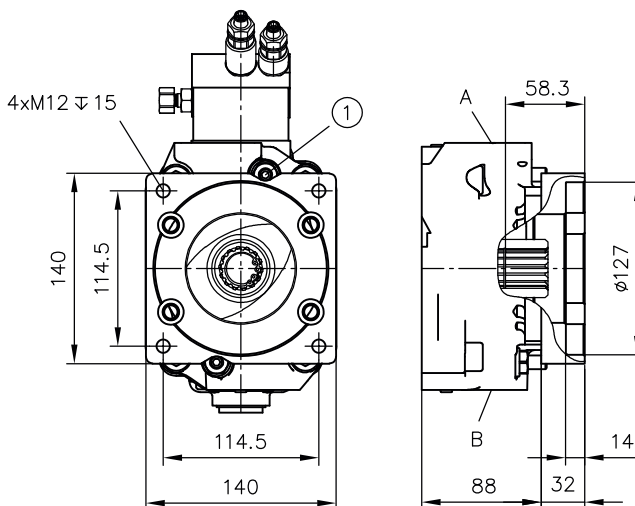

1 Stroke limitation

1 Stroke limitation

### 4.1.3 Type V60N-110 series 03

Rotation direction **clockwise** (viewed from shaft journal)

#### V60N-110 R

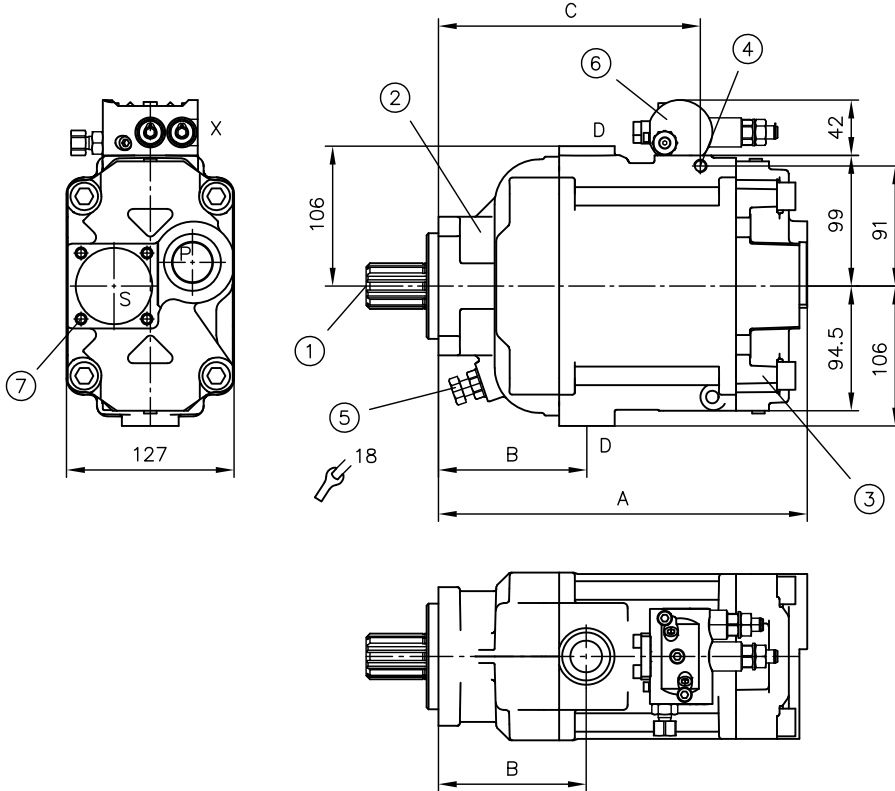

Rotation direction **anti-clockwise** (viewed from shaft journal)

#### V60N-110 L

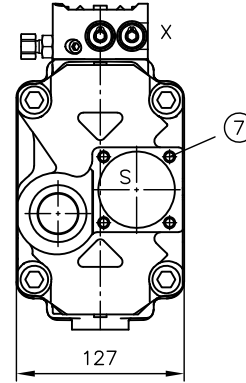

- 1 Shaft journal
- 2 Flange version
- 3 Thru-shaft
- 4 Thread M10 for attaching a support
- 5 Stroke limitation (12 cm<sup>3</sup>/rev.)
- 6 Controller and intermediate plates see Chapter 4.2, "Controllers and intermediate plates"
- 7 Attachment kit for suction intake see Chapter 6.1.1, "Suction intake" (included)

Flange version	Thru-shaft	A	B	C
Y	-1	279.5	112.0	201.0
F	-1	275.7	108.7	197.7
P	-1	278.5	111.0	200.0
Y	-2, -3	313.5	112.0	201.0
F	-2, -3	309.7	108.2	197.7
P	-2, -3	312.5	111.0	200.0

#### Ports P, S and D (ISO 228-1)

P	Pressure port G 1
S	Flange suction port
D	Drain port G 3/4
X	G 1/4

#### For coding UNF, ports SAE J 514

P	Pressure port 1 5/16-12 UN-2B
S	Flange suction port
D	Drain port 1 1/16-12 UN-2B
X	G 1/4 (ISO 228-1) with adapter to 7/16-20 (SAE-4)

**Shaft journal**

**Parallel key splined shaft**

Coding **D**

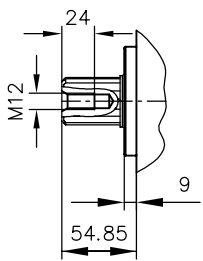

**Spline shaft**

Coding **S**

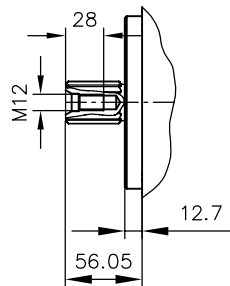

Coding **M**

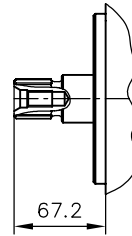

Coding **Q**

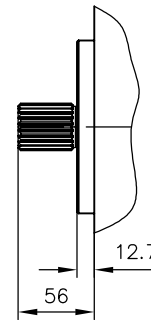

**Flange version (input side)**

Coding **Y**

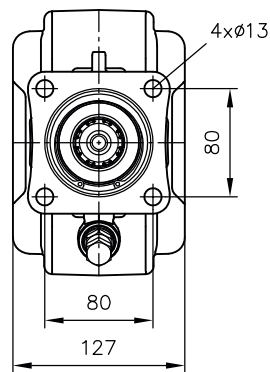
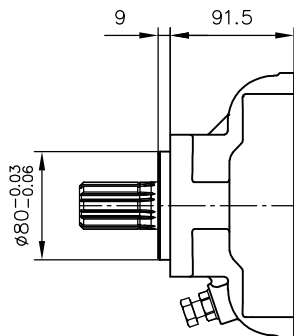

Coding **F**

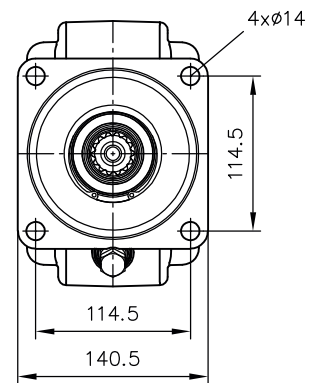
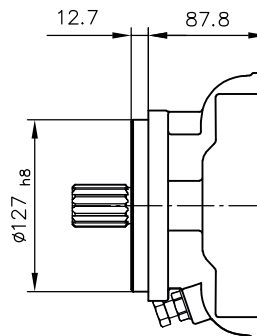

Coding **P**

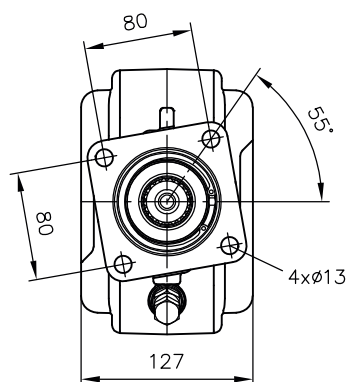
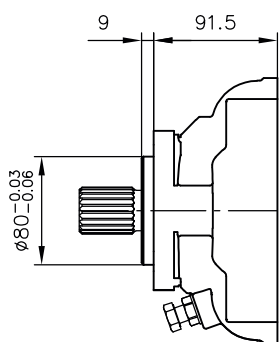

Coding **G**

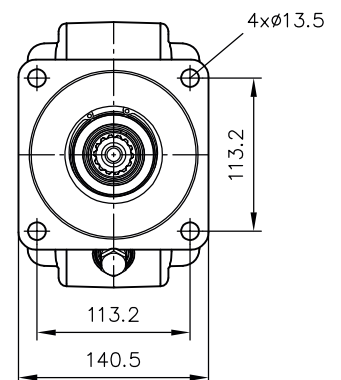
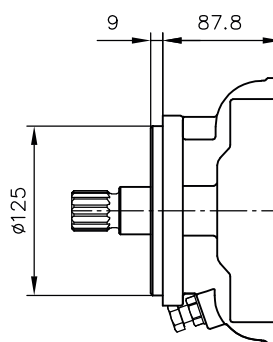

**Thru-shaft**

**Housing version (axial ports)**

**V60N-110 ...-1**

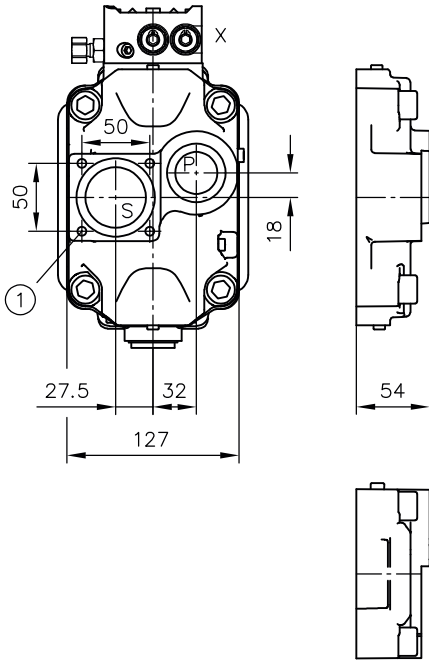

- 1 Attachment kit for suction intake see Chapter 6.1.1, "Suction intake" (included)

Housing version (radial ports with thru-shaft)

V60N-110 ...-2

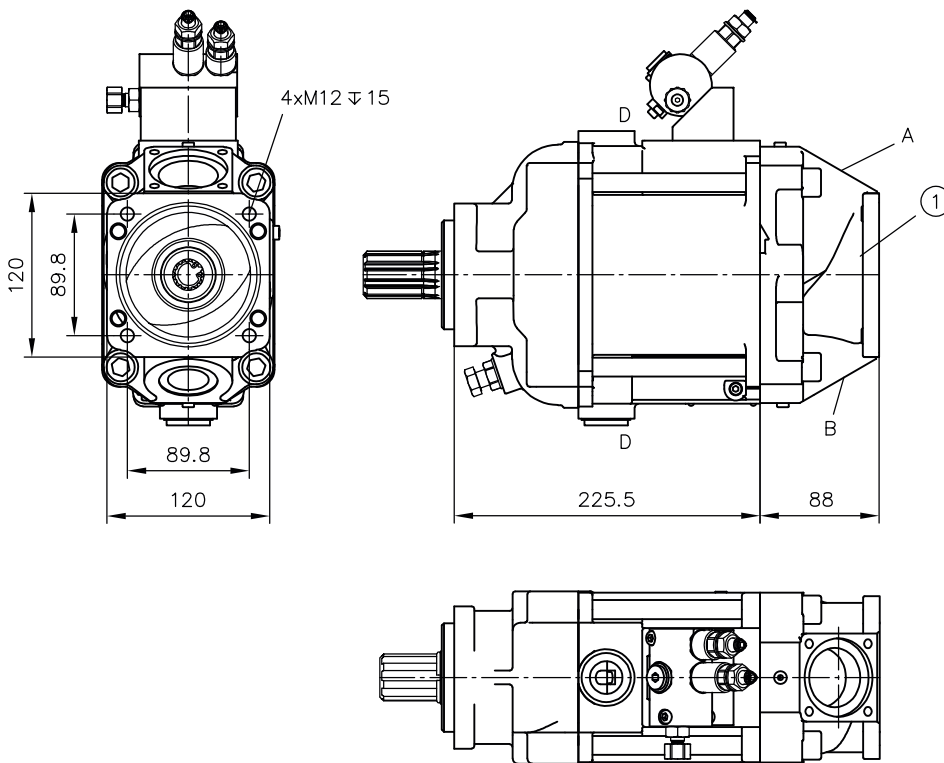

1 Flange version (output side)

Rotation direction clockwise	Rotation direction anti-clockwise
A = suction port	A = pressure connection
B = pressure connection	B = suction port

Housing version (radial ports)

V60N-110 ...-3

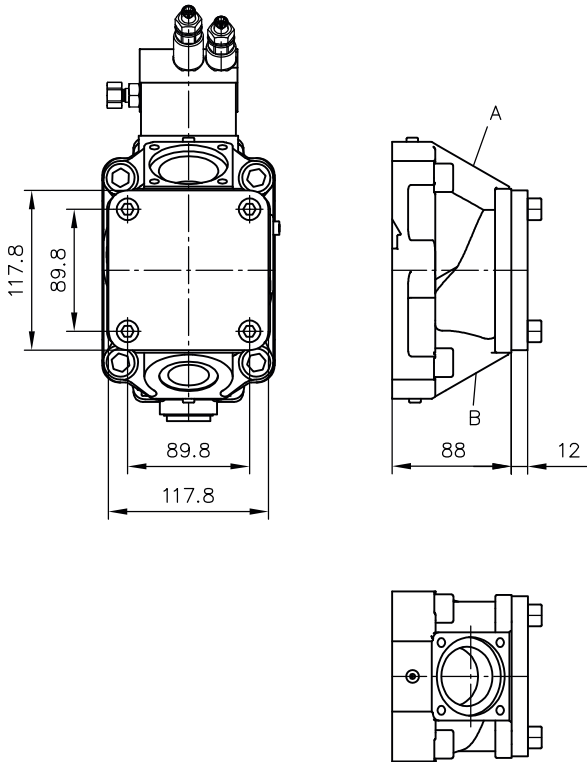

**Rotation direction clockwise**

A = suction port

B = pressure connection

**Rotation direction anti-clockwise**

A = pressure connection

B = suction port

**Flange version (output side)**

Coding C 021, C 022

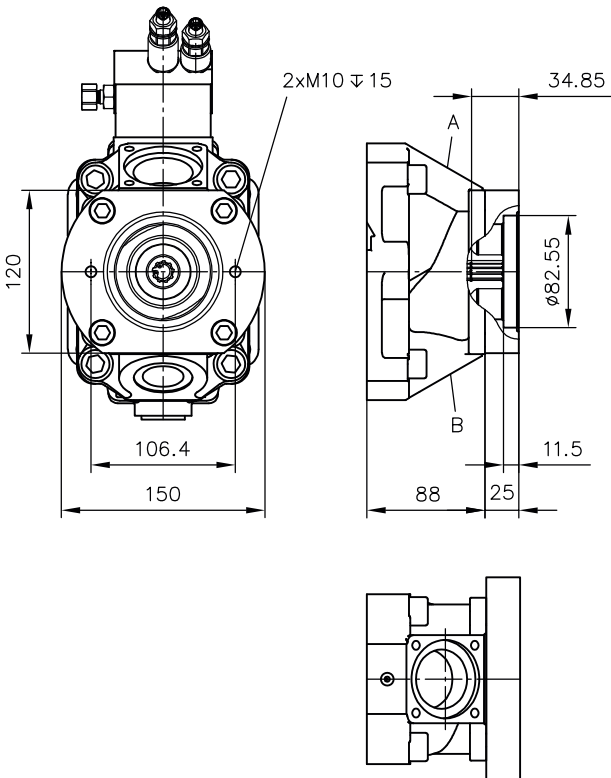

Coding C 024, C 026

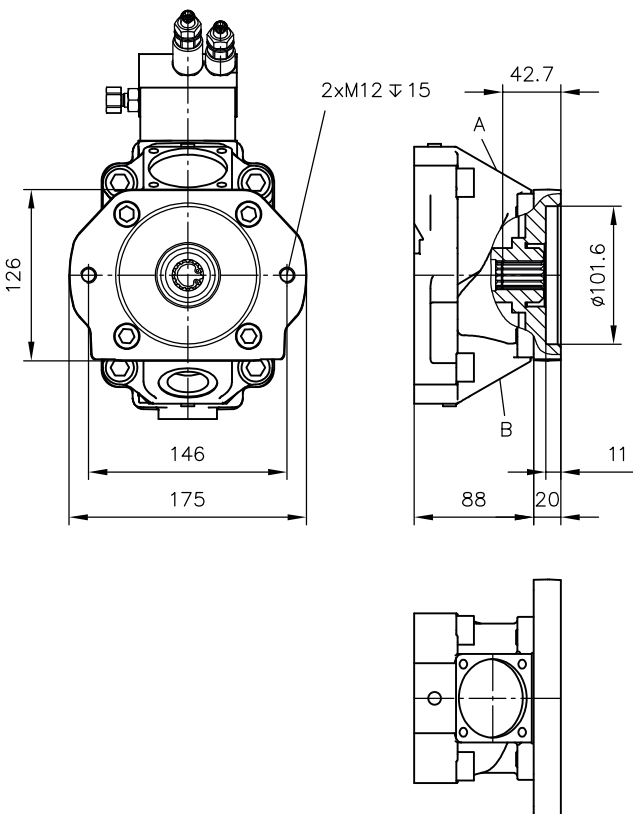

Coding C 025

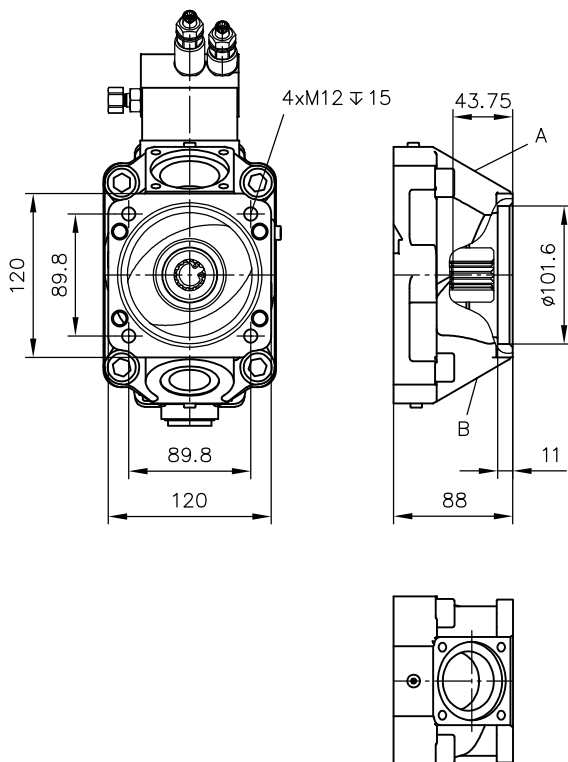

Coding C 027

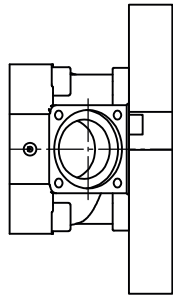
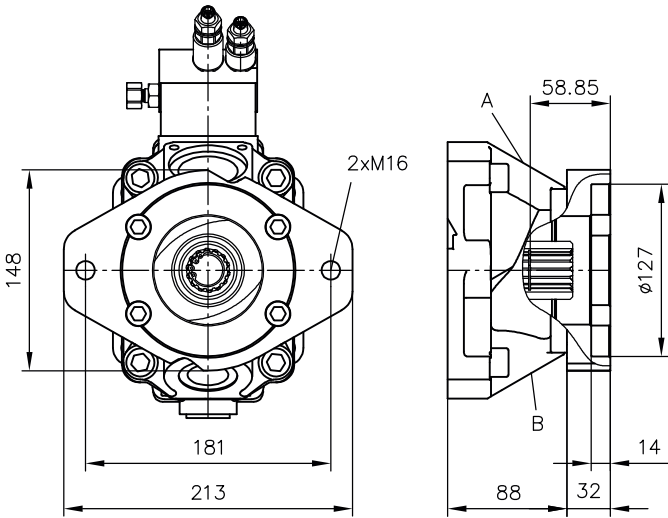

Coding C 028

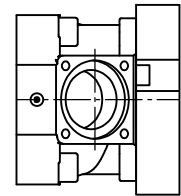
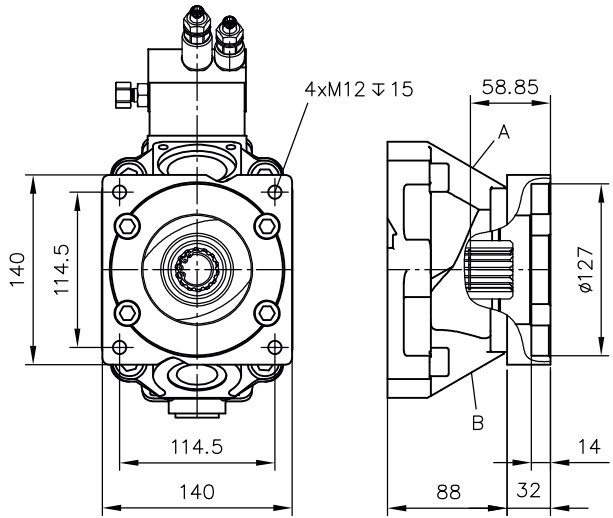

### 4.1.4 Type V60N-110 series 04 / V60N-130

Rotation direction **clockwise** (viewed from shaft journal)

#### V60N-130 R

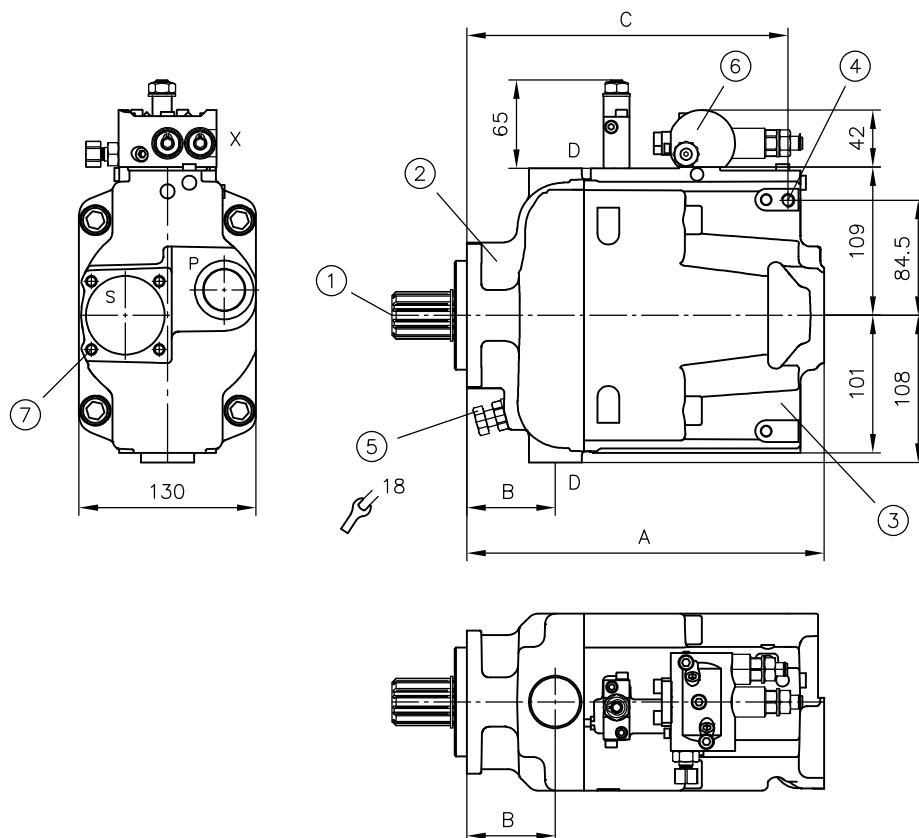

Rotation direction **anti-clockwise** (viewed from shaft journal)

#### V60N-130 L

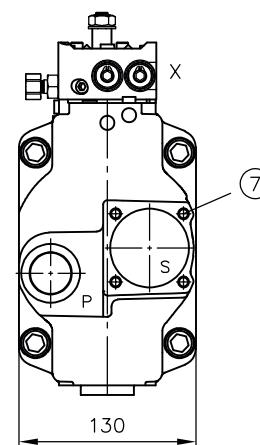

- 1 Shaft journal
- 2 Flange version
- 3 Thru-shaft
- 4 Thread M10 for attaching a support
- 5 Stroke limitation (13 cm<sup>3</sup>/rev.)
- 6 Controller and intermediate plates [see Chapter 4.2, "Controllers and intermediate plates"](#)
- 7 Attachment kit for suction intake [see Chapter 6.1.1, "Suction intake"](#) (included)

Flange version	Thru-shaft	A	B	C
Y, P	-1	262.5	65	236
F	-1	263.3	65.8	236.8
Y, P	-2	319	65	236
F	-2	319.8	65.8	236.8

#### Ports P, S and D (ISO 228-1)

P	Pressure port G 1
S	Flange suction port
D	Drain port G 3/4
X	G 1/4

#### For coding UNF, ports SAE J 514

P	Pressure port 1 5/16-12 UN-2B
S	Flange suction port
D	Drain port 1 1/16-12 UN-2B
X	G 1/4 (ISO 228-1) with adapter to 7/16-20 (SAE-4)

**Shaft journal**

**Spline shaft**

Coding **D**

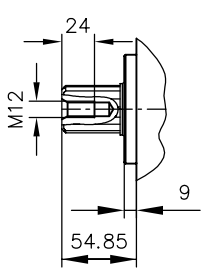

Coding **S**

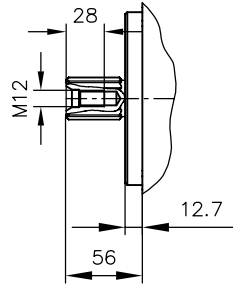

Coding **Q**

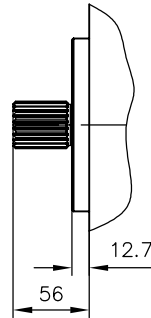

**Flange version (input side)**

Coding **Y**

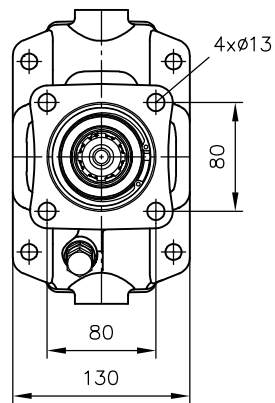
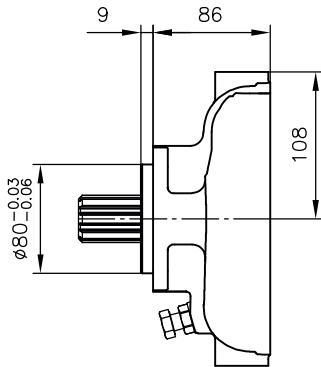

Coding **F**

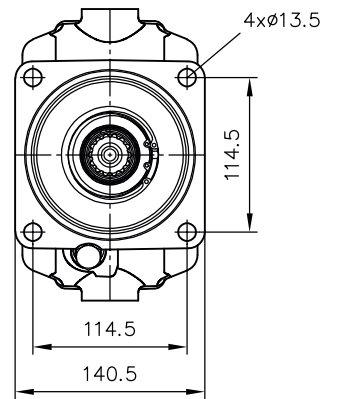
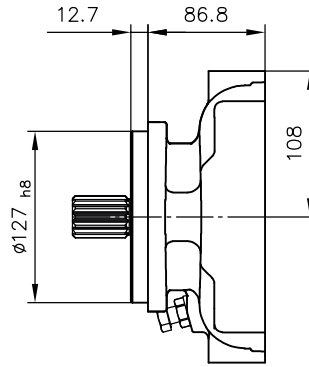

Coding **P**

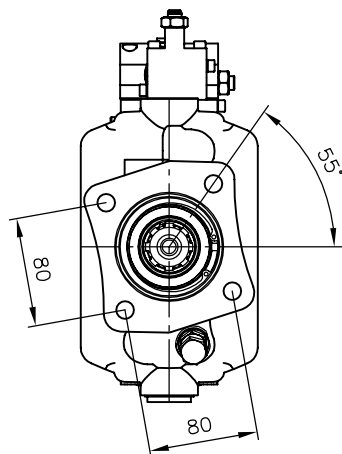
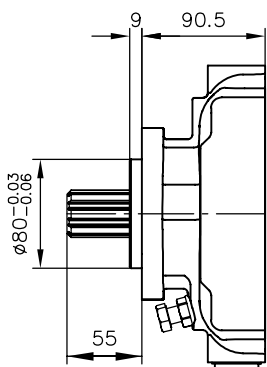

**Thru-shaft**

**Housing version (axial ports)**

V60N-130 ...-1

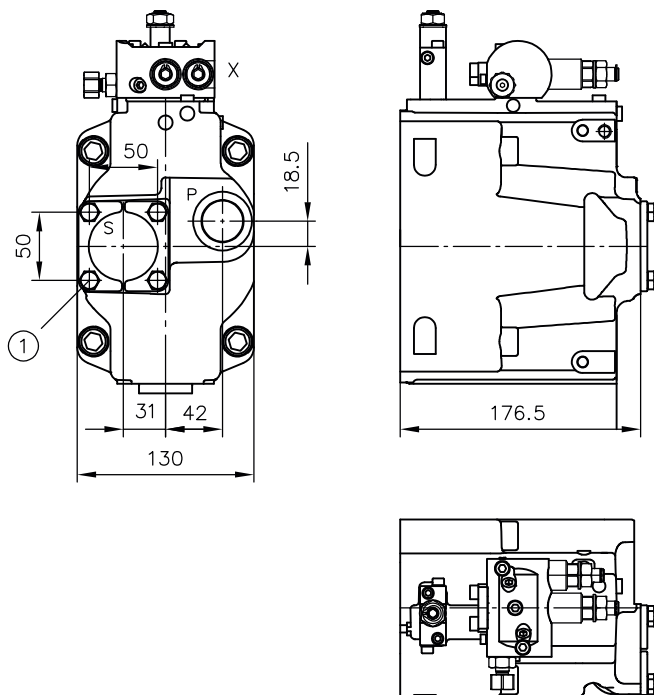

1 Attachment kit for suction intake see Chapter 6.1.1, "Suction intake" (included)

**Housing version (radial ports, with thru-shaft)**

Rotation direction **clockwise**

V60N-130 R ...-2

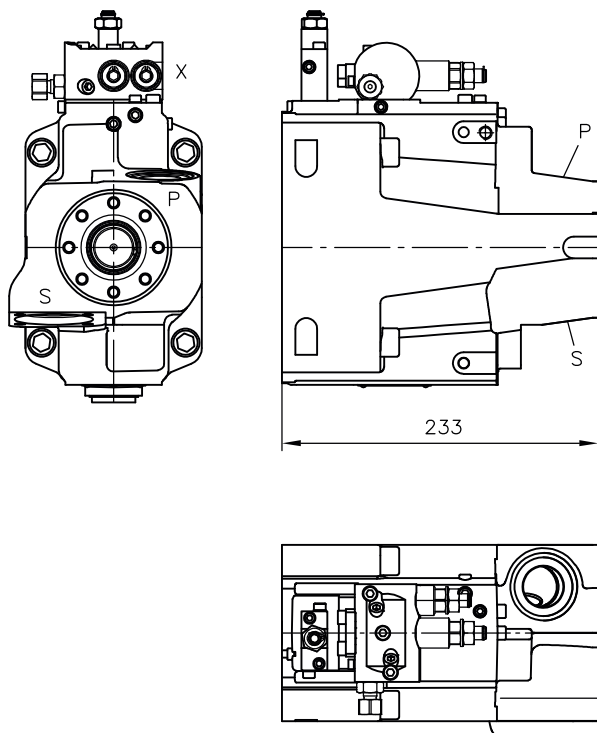

Rotation direction **anti-clockwise**

V60N-130 L ...-2

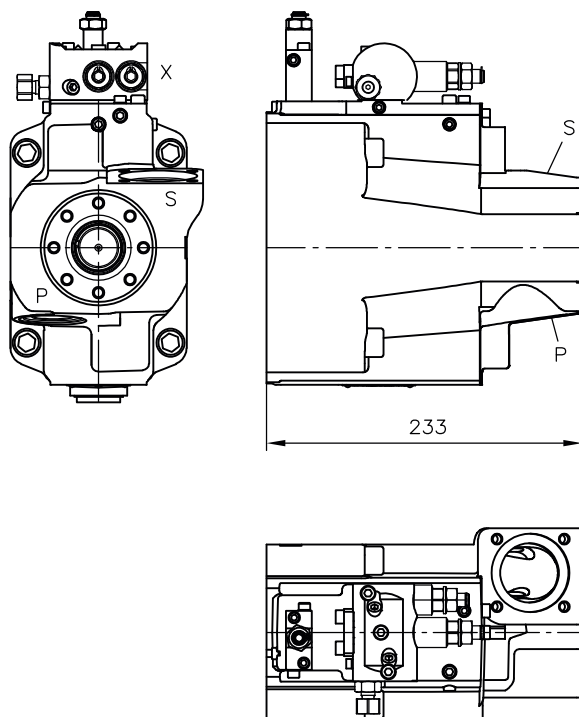

Housing version (radial ports)

V60N-130 ...-3

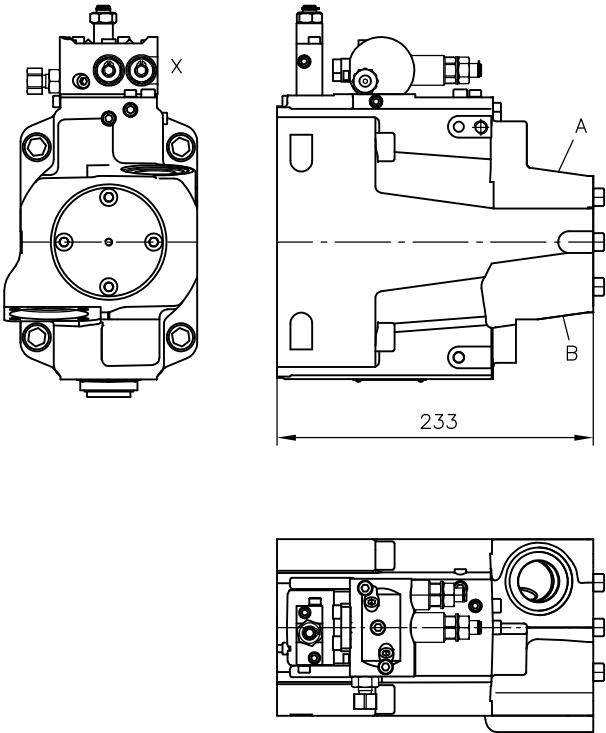

**Rotation direction clockwise**

A = pressure connection

B = suction port

**Rotation direction anti-clockwise**

A = suction port

B = pressure connection

**Flange version (output side)**

Coding C 030

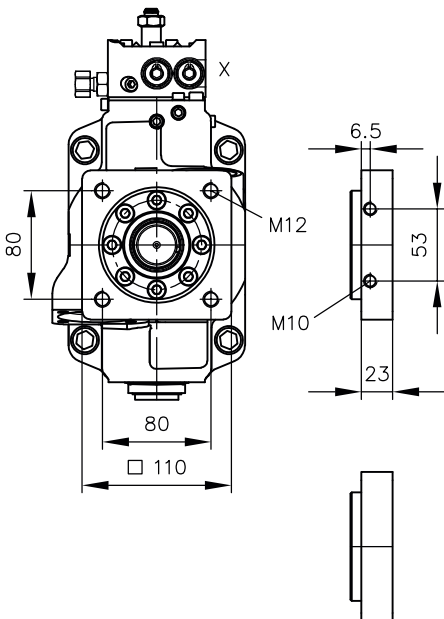

Coding C 031

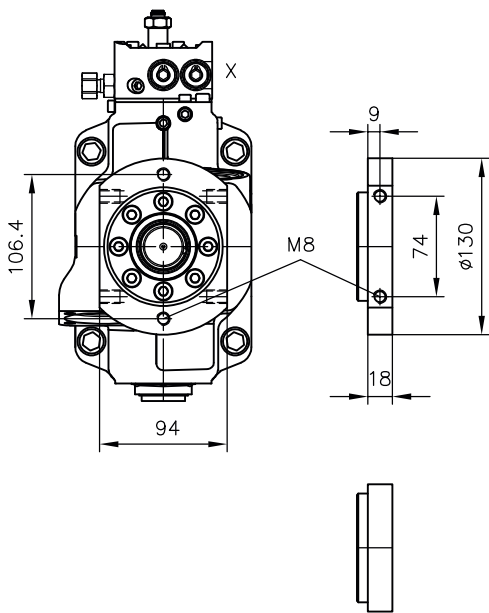

Coding C 034

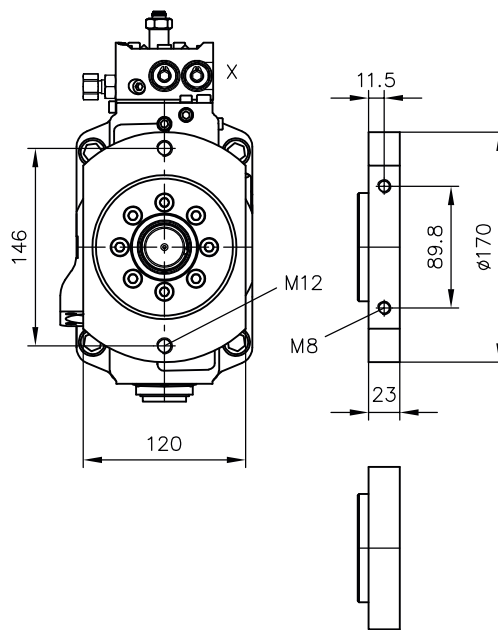

Coding C 035

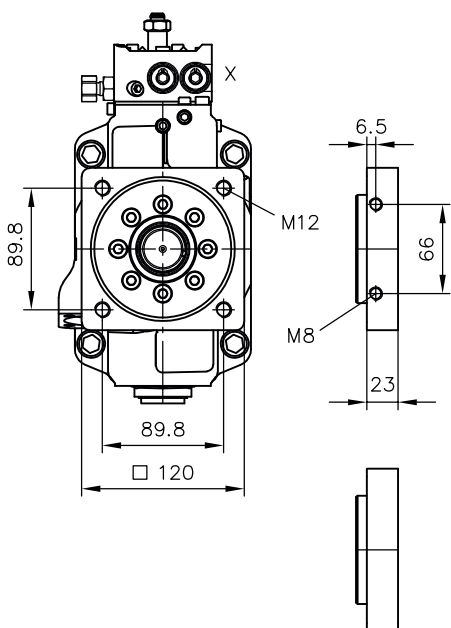

Coding C 038

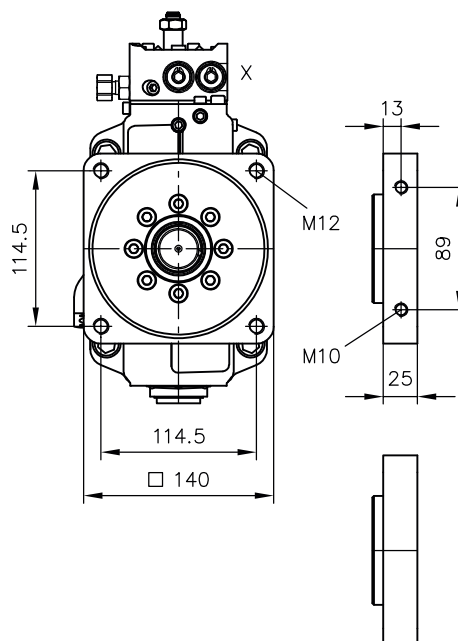

## 4.2 Controllers and intermediate plates

Coding P, LSP, LSPT

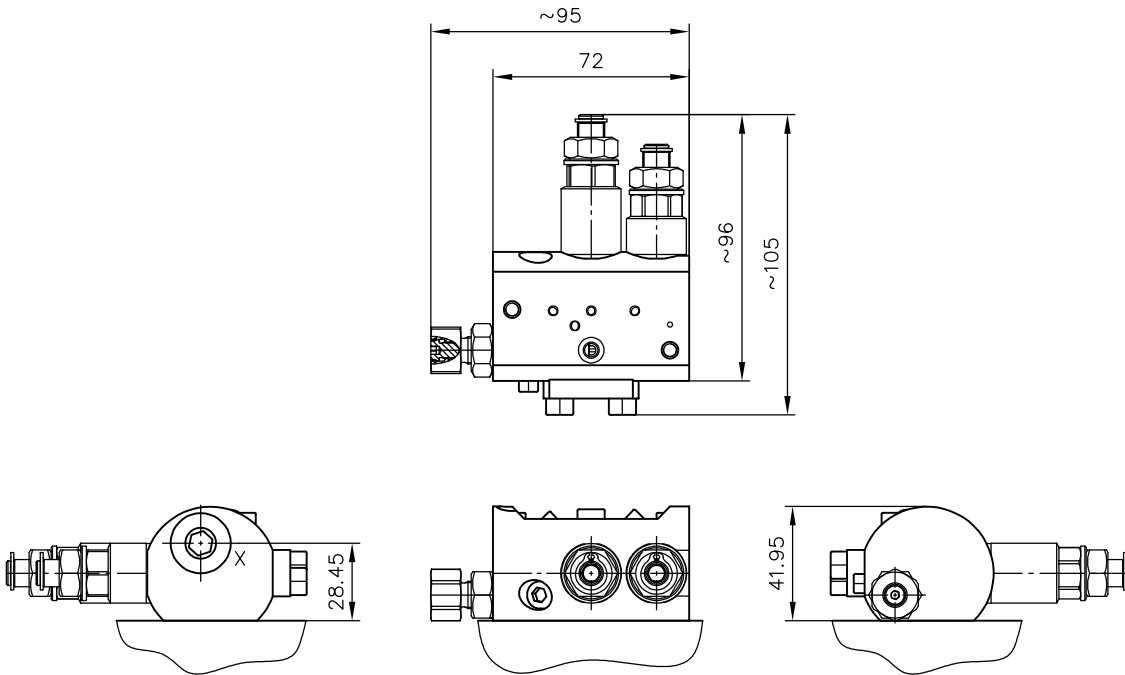

Coding QP

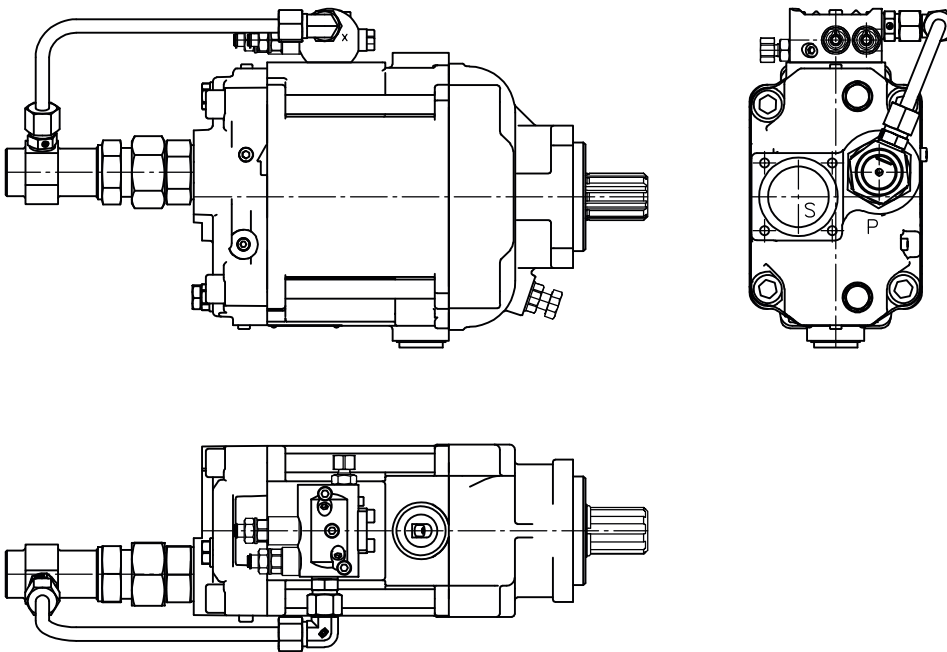

**!** **INFORMATION**

The piping varies depending on the size and rotation direction.

Coding **Pe, P3e**

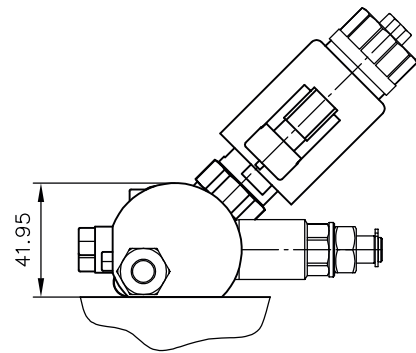
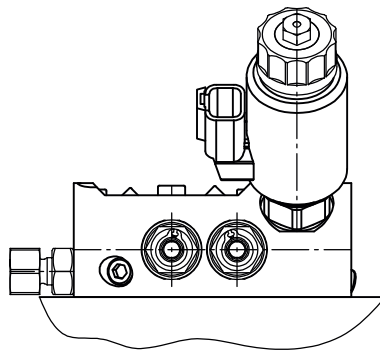
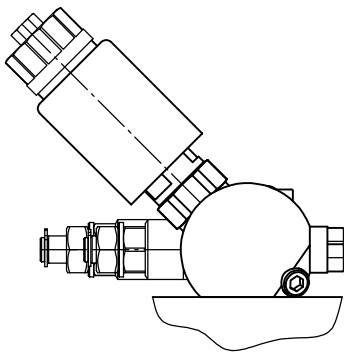
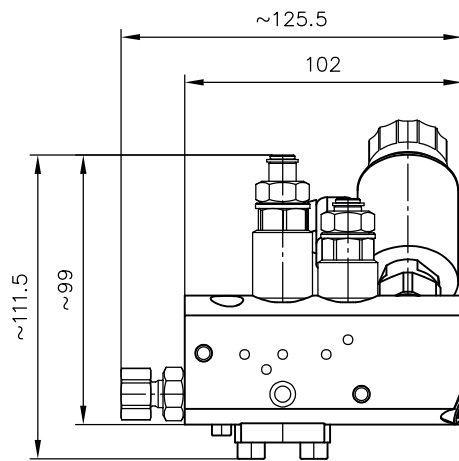

Coding **Pe1 and P3e1**

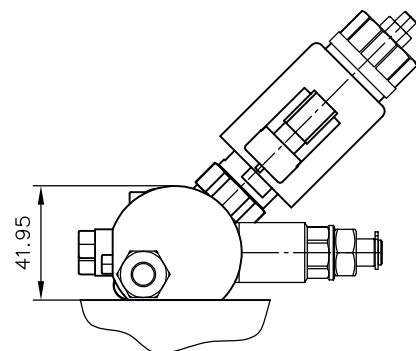
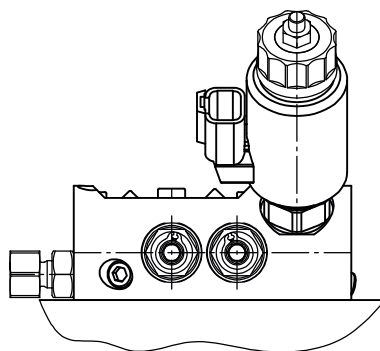
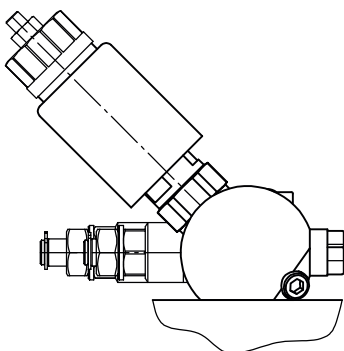
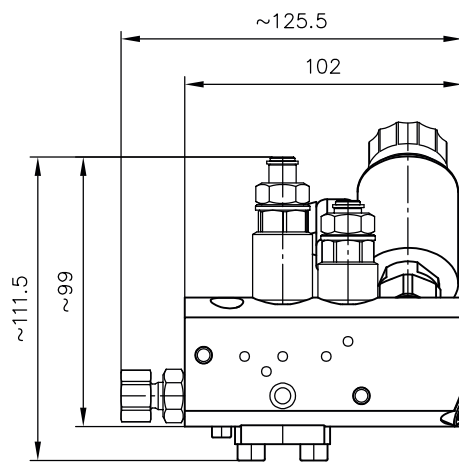

Coding V

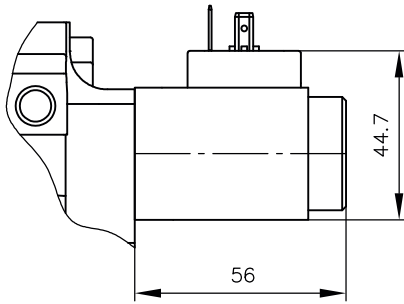

Coding L (only for type V60N-130)

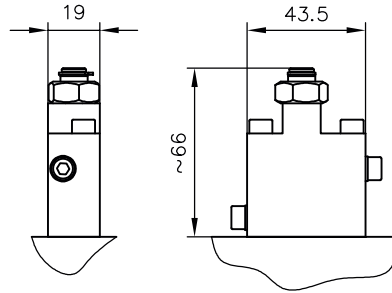

**Intermediate plates**

Coding ZW

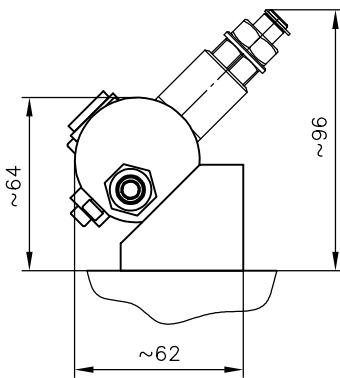

Coding ZL

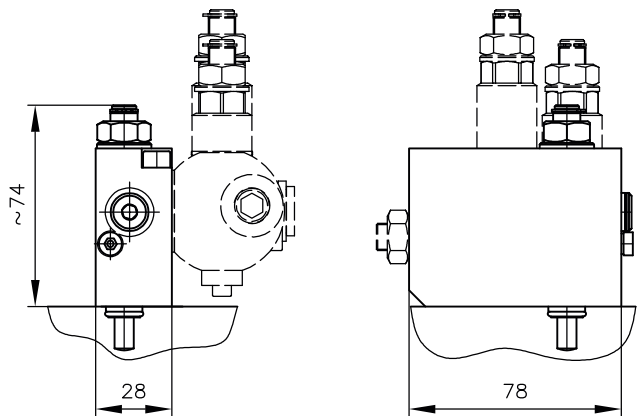

Coding ZV, ZV1

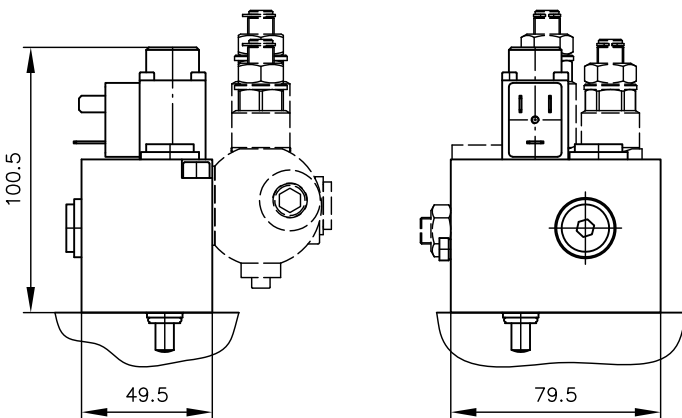

Coding ZLV, ZLV1

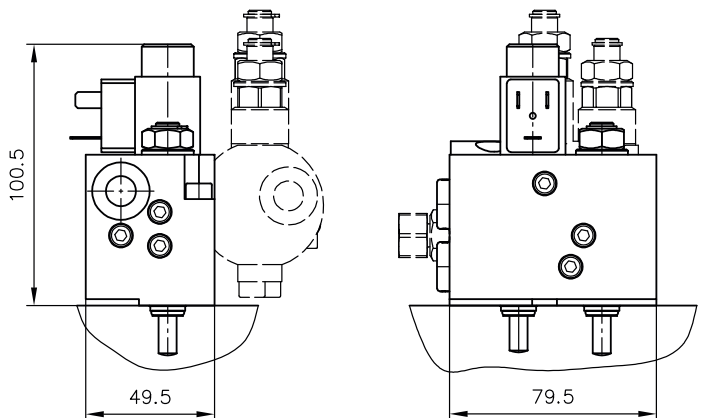

**⚠ WARNING**

**Overloading components due to incorrect pressure settings.**

Risk of serious injury or death.

- Pay attention to the maximum operating pressure of the pump and the valves.
- Only trained personnel are permitted to set and change the pressure and they must always monitor the pressure gauge when doing so.

## 5 Installation, operation and maintenance information

Observe the document B 5488 "General operating instructions for assembly, commissioning, and maintenance."

### 5.1 Intended use

This product is intended exclusively for hydraulic applications (fluid technology).

The user must observe the safety measures and warnings in this document.

#### Essential requirements for the product to function correctly and safely:

- ▶ All information in this documentation must be observed. This applies in particular to all safety measures and warnings.
- ▶ The product must only be assembled and put into operation by specialist personnel.
- ▶ The product must only be operated within the specified technical parameters described in detail in this document.
- ▶ All components must be suitable for the operating conditions when using an assembly.
- ▶ The operating instructions for the components, assemblies and the specific complete system must also always be observed.

#### If the product can no longer be operated safely:

1. Remove the product from operation and mark it accordingly.
  - ✓ It is then not permitted to continue using or operating the product.

### 5.2 Assembly information

The product must only be installed in the complete system with standard and compliant connection components (screw fittings, hoses, pipes, fixtures etc.).

The product must be shut down correctly prior to disassembly (in particular in combination with hydraulic accumulators).



#### DANGER

#### Sudden movement of the hydraulic drives when disassembled incorrectly

Risk of serious injury or death

- ▶ Depressurise the hydraulic system.
- ▶ Perform safety measures in preparation for maintenance.

#### 5.2.1 General information

The variable displacement axial piston pump is suitable for use in an open or semi-closed circuit.

The pump can be flange-mounted on the usual mounting points (e.g. gearbox power take-off, combustion engine or electric motor, cardan shaft). Suitable coupling flanges are available as accessories for attachment to a cardan shaft "coupling flanges for cardan shafts".

In order to reduce the weight torque of the pump, a separate support can be attached in addition to the flange mounting. For this purpose, M10 threads are included in the pump housing (only V60N-090/110/130) see Chapter 4, "Dimensions". A change of rotating direction is available for types V60N-060, V60N-090 and V60N-110 variable displacement axial piston pumps. For conversion instructions, please get in touch with HAWE Hydraulik SE. The housing pressure in the pump must always be greater than or equal to the ambient pressure.

#### During assembly, note the following principles:

- Only trained persons are allowed to mount or remove the pump.
- Always ensure absolute cleanliness to prevent contamination from affecting the pump.
- Remove all plastic plugs before operation.
- Avoid installation above the tank (see Chapter 5.2.3, "Installation positions").
- Observe the electric reference values.

- Before initial use, fill the pump with hydraulic fluid and bleed. Automatic pump filling via the suction line by opening the drain ports is not possible.
- Always supply the pump with hydraulic fluid from the start. Even just a short period with insufficient hydraulic fluid can damage the pump. Such damage is not immediately visible once the pump is put into operation.
- Never drain the pump.
- Hydraulic fluid which flows back into the tank must not be sucked back in immediately (install baffles!).
- If there is a check valve installed in the leakage line, negative pressure may occur in the pump housing during operation. If this happens, install an auxiliary pump to flush the housing.
- Before first use, run the pump for approx. 10 minutes at max. 50 bar after initial start-up.
- The leakage line must be installed in the tank in such a way that it ends below the oil level. The end of the leakage line should be positioned roughly equidistant from both the bottom of the tank and the oil level.
- Do not use the entire pressure range of the pump until it has been thoroughly bled and flushed.
- From the start, always keep the temperature within the specified range . Never exceed the maximum temperature.
- Always comply with the cleanliness level of the hydraulic fluid. In addition, filter the hydraulic fluid appropriately .
- Self-installed filters in the suction line must be approved beforehand by HAWE Hydraulik.
- A system pressure-limiting valve must be installed in the pressure line so that the maximum system pressure is not exceeded.

### 5.2.2 Connections

The connecting lines' nominal width depends on:

- the given usage conditions
- viscosity of the hydraulic fluid
- start-up and operating temperature
- pump speed

HAWE recommends: Use hose lines (improved damping characteristics) instead of rigid pipelines.

<b>Pressure connection</b>	<ul style="list-style-type: none"> <li>▪ The pressure connection on type V60N-060 is a threaded connection G 3/4", and on type V60N-090/110/130 a threaded connection G 1".</li> <li>▪ Observe the fitting manufacturers' specified tightening torques.</li> </ul>																							
<b>Suction port</b>	<ul style="list-style-type: none"> <li>▪ The suction port on all pumps is established via standardised suction intakes with a size which depends on the max. delivery flow of the pump. The specifications for the max. delivery flow <math>Q_{max}</math> must be observed.</li> </ul> <table border="1" style="width: 100%; border-collapse: collapse;"> <thead> <tr> <th style="text-align: left;">Nominal width (N)</th> <th>38 (1 1/2")</th> <th>42</th> <th>50 (2")</th> <th>64 (2 1/2")</th> <th>76 (3")</th> <th>6 (1 1/4)</th> <th>7 (1 1/2)</th> </tr> </thead> <tbody> <tr> <td style="text-align: left;"><math>Q_{max}</math> (l/min)</td> <td>75</td> <td>90</td> <td>125</td> <td>190</td> <td>250</td> <td>90</td> <td>125</td> </tr> </tbody> </table> <ul style="list-style-type: none"> <li>▪ The suction intakes can be ordered as an option with the pump.</li> <li>▪ If possible, route the suction line to the tank on a rising gradient. This allows trapped air to escape.</li> <li>▪ The absolute suction pressure must not fall below 0.85 bar.</li> <li>▪ A hose line should generally be used in preference to a rigid pipe line.</li> </ul>								Nominal width (N)	38 (1 1/2")	42	50 (2")	64 (2 1/2")	76 (3")	6 (1 1/4)	7 (1 1/2)	$Q_{max}$ (l/min)	75	90	125	190	250	90	125
Nominal width (N)	38 (1 1/2")	42	50 (2")	64 (2 1/2")	76 (3")	6 (1 1/4)	7 (1 1/2)																	
$Q_{max}$ (l/min)	75	90	125	190	250	90	125																	
<b>Drain port</b>	<ul style="list-style-type: none"> <li>▪ The pump features 2 drain ports G 3/4" or 1 1/16-12-UN-2B. In addition, the flange version SAE-B2, SAE-B4 and SAE-4 has a threaded connection G 1/8". This is used for bleeding in the case of vertical installation positions.</li> <li>▪ The nominal width of the leakage line must not be less than 16 mm. The cross-section is determined by the max. permissible housing pressure.</li> <li>▪ Integrate the leakage line in the system in such a way as to prevent direct connection with the suction line of the pump.</li> <li>▪ All drain ports can be used simultaneously.</li> <li>▪ A separate leakage line from the controller to the tank is not required.</li> <li>▪ Do not install a check valve in the leakage line!</li> </ul>																							

#### LS port on LSP, LSPT version

- The LS line is connected to the controller via a G 1/4" threaded connection.
- The nominal width of the line depends on the mounting position of the pump and should be 10% of the pressure line capacity. A hose line should generally be used in preference to a rigid pipe connection.
- When the proportional directional spool valve is in neutral position, the LS line must always be fully relieved (controller type LSP only)! For controller type LSPT relief is carried out within the controller.

### 5.2.3 Installation positions

The variable displacement axial piston pump can be mounted in any installation position.

#### Horizontal installation

- ▶ For horizontal installation, use the uppermost drain port.



#### Vertical installation

Pump below the min. fill level

- ▶ Mount the pump so that the pump mounting flange is facing upwards.
- ▶ For vertical installation, use the uppermost drain port.
- ▶ Also connect the G 1/8" venting port to the pump flange (see Chapter 4, "Dimensions").
- ▶ Take appropriate measures to ensure continuous venting of this line (line routing/venting).

For installation with pump flange facing downwards: Get in touch with HAWE Hydraulik SE.

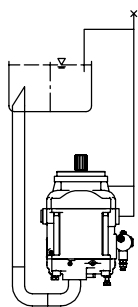

## 5.2.4 Tank installation

### Pump below the min. fill level

The pump can be operated either with or without a suction intake. Using a short suction intake is recommended.



### Pump above the fill level

**!** NOTICE

The pump must not run dry via the pressure, intake, drain, venting or control lines. This applies in particular to long periods of downtime.

- ▶ The leakage line must be installed in the tank in such a way that it ends below the oil level.
- ▶ Facilitate venting of connecting lines via separate vent openings.
- ▶ Adjust the venting sequence to suit the specific installation.
- ▶ If necessary, a gear pump should be provided in order to draw air from the suction line.

Contact form for special consultation on axial piston pump design:

Checklist for variable displacement axial piston pump design: B 7960 checklist

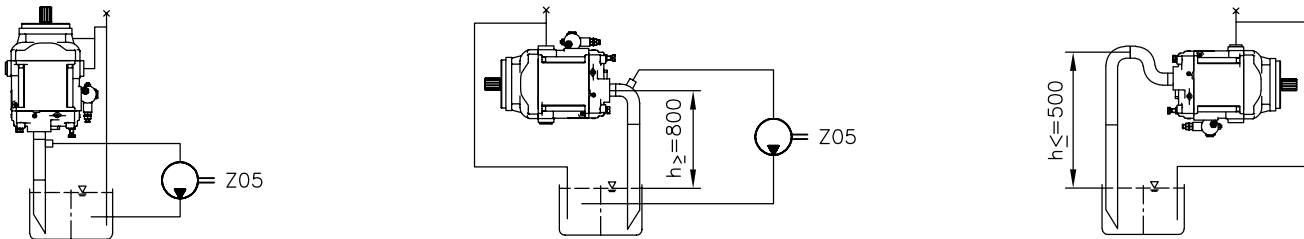

For further information on installation, operation and maintenance, see the relevant assembly instructions: [B 7960](#), [B 5488](#).

## 5.3 Operating instructions

Observe product configuration and pressure/flow rate.

The statements and technical parameters in this document must be strictly observed.

The instructions for the complete technical system must also always be followed.

### NOTICE

- ▶ Read the documentation carefully before usage.
- ▶ The documentation must be accessible to the operating and maintenance staff at all times.
- ▶ Keep documentation up to date after every addition or update.

### CAUTION

#### **Overloading components due to incorrect pressure settings.**

Risk of minor injury. Parts may burst or fly off, and uncontrolled leakage of hydraulic fluid.

- Pay attention to the maximum operating pressure of the pump, valves and fittings.
- Always monitor the pressure gauge when setting and changing the pressure.

## Purity and filtering of the hydraulic fluid

Fine contamination can significantly impair the function of the product. Contamination can cause irreparable damage.

### Examples of fine contamination include:

- Swarf
- Rubber particles from hoses and seals
- Dirt due to assembly and maintenance
- Mechanical debris
- Chemical ageing of the hydraulic fluid

### NOTICE

#### **New hydraulic fluid from the manufacturer may not have the required purity.**

Damage to the product is possible.

- ▶ Filter new hydraulic fluid to a high quality when filling.
- ▶ Do not mix hydraulic fluids. Always use hydraulic fluid that is from the same manufacturer, of the same type, and with the same viscosity properties.

For smooth operation, pay attention to the cleanliness level of the hydraulic fluid (cleanliness level see Chapter 3, "Parameters").

Additionally applicable document: [D 5488/1](#) oil recommendations

## Restrictions in operation during cold start phase and warm-up phase

Phase	Temperature	Viscosity (mm <sup>2</sup> /s)
Cold start phase	-25 to -40°C	< 1000
Warm-up phase	-25 to 80 °C	500 to 1000
Normal operation	-25 to 80 °C	10 to 500

### NOTICE

Optimum range: 16 - 60 mm<sup>2</sup>/s

### Cold start phase:

- $p_B = 20 - 30$  bar
- $n \leq 1000$  rpm

**Warm-up phase:**

- $p_B = 20 - 200 \text{ bar}$
- $n \leq 1500 \text{ rpm}$

**Normal operation:**

- No further restrictions. Operating conditions see [Chapter 3, "Parameters"](#).

## 5.4 Maintenance information

This product is largely maintenance-free.

Check regularly (at least once a year) by visual inspection whether the hydraulic connections are damaged. If external leakages are found, shut down and repair the system.

Clean the surface of the device regularly (at least once a year) (dust deposits and dirt).

## 6 Other information

### 6.1 Accessories, spare and individual parts

To purchase spare parts, please see [HAWE Hydraulik interactive contact map](#).

#### 6.1.1 Suction intake

##### Ordering example

V60N - 090 R DY N - 1 - 0 - 01/LSP - 350 - A00/76

Nominal width (N)	Flow rate $Q_{max}$ (l/min)	Geometric shape									
		Straight		45°		90°		Thread	Order no.		
		Order no.	Order no.	Order no.	Order no.						
		A00/..	A45/..	A90/..	A.						
h	h	k	h	k	h						
38 (1 1/2")	75	65	79 93336 00	--	--	--	53	70	79 93344 00	--	--
42 (1 5/8")	90	--	--	85	40	79 93340 00	--	--	--	--	--
50 (2")	125	65	79 93337 00	96	40	79 93341 00	53	84	79 93345 00	--	--
64 (2 1/2")	190	90	79 93338 00	96	40	79 93342 00	109	129	79 93346 00	--	--
76 (3")	250	106	79 93339 00	106	40	79 93343 00	--	--	--	--	--
7 (1 1/2")	125	--	--	--	--	--	--	--	--	28.5	79 40719 00
7 UNF (7/8-12 UN-2B)	125	--	--	--	--	--	--	--	--	28.5	79 41599 00

A00/..

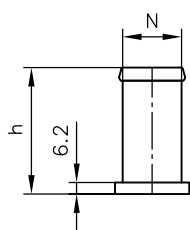

A45/..

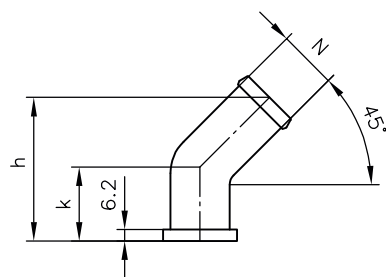

A90/..

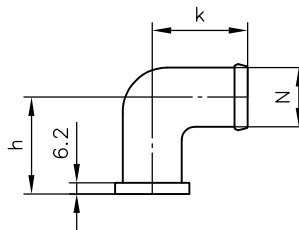

A7

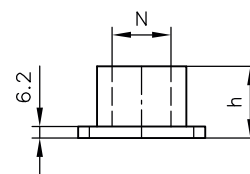

The attachment kit for suction intake (included) comprises:

- 4x hex bolts M8x16-8.8 (tightening torque 24 Nm)
- O-ring 44.2x3 NBR 70 Sh
- 2 mounting flange halves

(Order no. 79 93355 00)

#### **i** INFORMATION

Use nominal width 38 (1 1/2") for reduced displacement volume only!

Installation information see Chapter 5, "Installation, operation and maintenance information"

## 6.1.2 Coupling flange for cardan shafts

Special coupling flanges for cardan shafts ( $\varnothing 100$ -6- $\varnothing 8$ ) according to ISO 7646.

For telescopic cardan shafts also with spacer ring and connecting screw for attachment to the drive shaft of the pump.

Coding **SAE-C, SAE-CS**

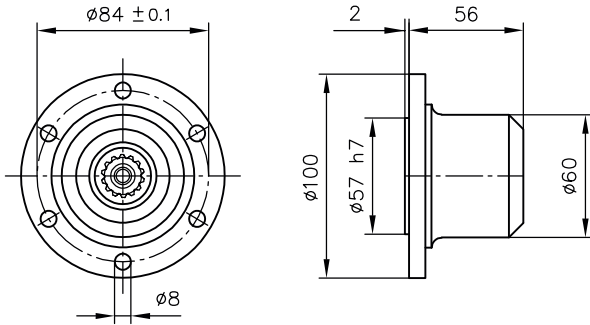

Coding **DIN ISO 014**

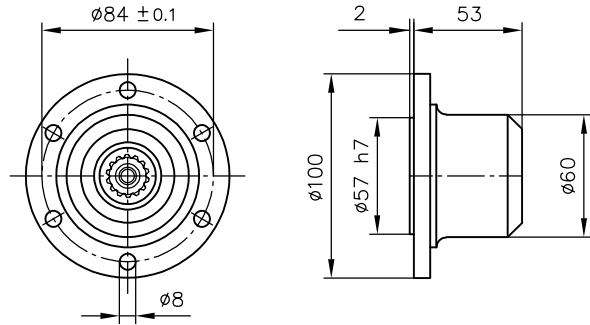

Coding	Spline profile	Order no.
SAE C	14T 12/24 DP	79 29555 00
SAE CS	21T 16/32 DP	79 42793 00
DIN ISO 14	B8x32x36	79 29709 00

Coding **SAE-C, SAE-CS, DIN ISO 014**

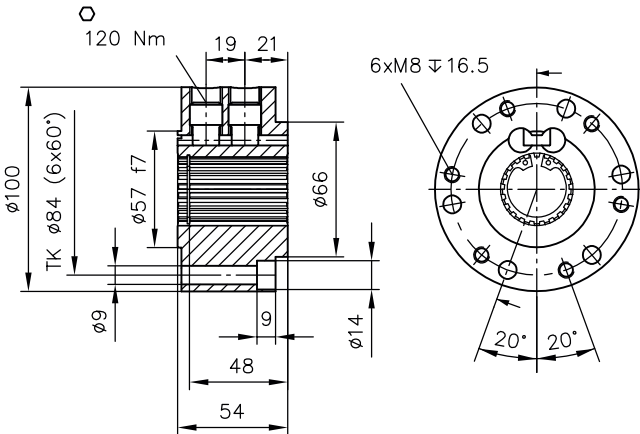

Coding	Spline profile	Order no.
SAE-C	14T 12/24 DP	79 94495 00
SAE-CS	21T 16/32 DP	79 94479 00
DIN ISO 14	B8x32x36	79 94496 00

## 6.2 Planning information

### Determination of nominal sizes

Delivery flow	$Q = \frac{V_g \cdot n \cdot \eta_V}{1000} \text{ (l/min)}$	Q = Flow rate (l/min)
Drive torque	$M = \frac{V_g \cdot \Delta p}{20 \cdot \pi \cdot \eta_{mh}} \text{ (Nm)}$	M = Torque (Nm)
Drive power	$P = \frac{2\pi \cdot M \cdot n}{60000} = \frac{Q \cdot \Delta p}{600 \cdot \eta_t} \text{ (kW)}$	P = Power (kW)
		V <sub>g</sub> = Geom. output volume (cm <sup>3</sup> /rev.)
		Δp = Differential pressure
		n = Speed (rpm)
		η <sub>V</sub> = Volumetric efficiency
		η <sub>mh</sub> = Mechanical-hydraulic efficiency
		η <sub>t</sub> = Overall efficiency (η <sub>t</sub> = η <sub>V</sub> · η <sub>mh</sub> )

## References

### Additional versions

- Variable displacement axial piston pump type V80M: D 7962 M
- Variable displacement axial piston pump type V30E: D 7960 E
- Variable displacement axial piston pump type V30D: D 7960
- Axial piston pump type C40V: D 7964
- Fixed displacement axial piston pump type K60N: D 7960 K
- Axial piston motors type M60N: D 7960 M
- Proportional directional spool valve type EDL: D 8086
- Proportional directional spool valves types PSL, PSV size 2: D 7700-2
- Proportional directional spool valves types PSL/PSV/PSM, size 3: D 7700-3
- Proportional directional spool valve, type PSL, PSM and PSV size 5: D 7700-5
- Proportional directional spool valve type PSLF, PSVF and SLF size 3: D 7700-3F
- Proportional directional spool valve type PSLF, PSVF and SLF size 5: D 7700-5F
- Proportional directional spool valve banks type PSLF and PSVF size 7: D 7700-7F
- Load-holding valve type LHT: D 7918
- Load-holding valve type CLHV: D 7918-VI-C
- Load-holding valve type CLHV: D 7918-VI-PIB
- Load-holding valve type LHDV: D 7770
- Proportional amplifier type EV1M3: D 7831/2
- Proportional amplifier type EV1D: D 7831 D
- Proportional amplifier type EV2S: D 7818/1

### Operating instructions

- General operating manual for the assembly, initial operation and maintenance of hydraulic components and systems: B 5488

