

Variable displacement axial piston pump type V30D

Product documentation



Open circuit

Nominal pressure $p_{\text{nom max}}$:

350 bar

Peak pressure p_{max} :

420 bar

Displacement volume V_{max} :

250 cm³/rev

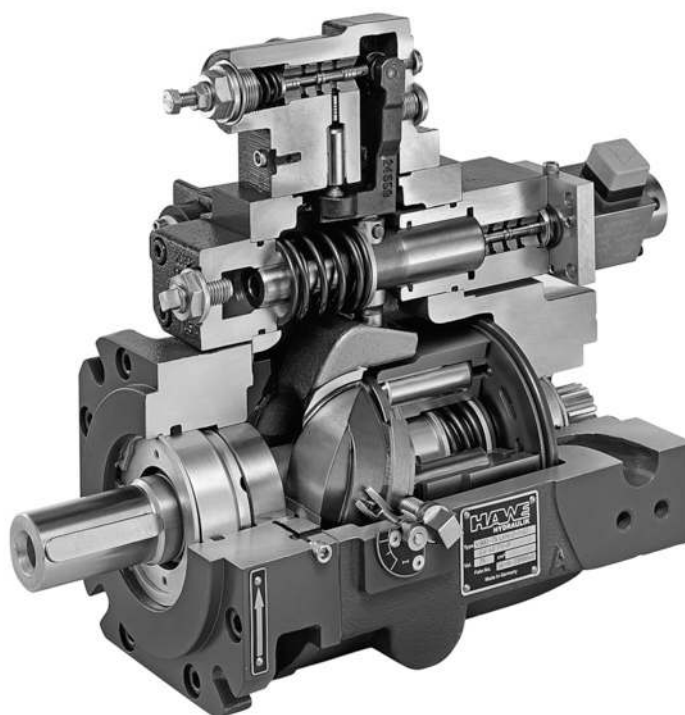

© by HAWE Hydraulik SE.

The reproduction and distribution of this document, as well as the use and communication of its contents to others without explicit authorization, is prohibited.

Offenders will be held liable for the payment of damages.

All rights reserved in the event of patent or utility model applications.

Brand names, product names and trademarks are not specifically indicated. In particular with regard to registered and protected names and trademarks, usage is subject to legal provisions.

HAWE Hydraulik respects these legal provisions in all cases.

HAWE Hydraulik cannot provide individual guarantees that the stated circuits or procedures (including in part) are not subject to the intellectual property rights of third parties.

Printing date / document generated on: 2024-09-16

Table of Contents

1	Overview: variable displacement axial piston pump type V30D.....	4
2	Available versions.....	5
2.1	Basic type and nominal size.....	5
2.2	Rotation direction.....	6
2.3	Shaft journal.....	6
2.4	Flange versions (input side).....	6
2.5	Seals.....	7
2.6	Thru-shaft.....	7
2.7	Swivel angle indicator.....	7
2.8	Controller.....	8
2.8.1	Load sensing controller LS, LSN, LSP, LSD.....	12
2.8.2	Pressure controller N, Nw, ND, NDw, P, Pb, PD5.....	16
2.8.3	Power controller L, Lw, Lf, Lf1.....	19
2.8.4	Delivery flow controller.....	23
2.8.5	Solenoid voltage and solenoid version.....	27
2.9	Stroke limitation.....	27
2.10	Flange version (output side).....	28
3	Parameters.....	29
3.1	General data.....	29
3.2	Weight.....	31
3.3	Pressure and delivery flow.....	31
3.4	Characteristic lines.....	32
3.4.1	Basic pump.....	32
3.4.2	Swivel angle pick-up.....	35
3.5	Electrical data.....	35
4	Dimensions.....	36
4.1	Basic pump.....	36
4.1.1	V30D-045.....	36
4.1.2	V30D-075.....	39
4.1.3	V30D-095/115.....	43
4.1.4	V30D-140/160.....	47
4.1.5	V30D-250.....	51
4.2	Swivel angle indicator.....	55
4.3	Controllers.....	56
5	Installation, operation and maintenance information.....	61
5.1	Intended use.....	61
5.2	Assembly information.....	61
5.2.1	General information.....	61
5.2.2	Connections.....	62
5.2.3	Installation positions.....	63
5.2.4	Tank installation.....	64
5.3	Operating instructions.....	65
5.3.1	Limitations.....	66
5.4	Maintenance information.....	66
6	Other information.....	67
6.1	Planning information.....	67

Overview: variable displacement axial piston pump type V30D

Variable displacement axial piston pumps adjust the geometric output volume from maximum to zero. As a result they vary the flow rate that is provided to the consumers.

The axial piston pump type V30D is designed for open circuits in industrial hydraulics and operates based on the swash plate principle. It is available with the option of a thru-shaft for operating with additional hydraulic pumps in series.

The sturdy pump is particularly suitable for continuous operation in challenging applications. The range of pump controllers allows the axial piston pump to be used in a variety of applications.

Features and advantages

- Low-noise
- Long lifetime even under demanding application conditions
- Broad selection of controllers
- Full torque available at the second pump in tandem pump applications

Applications

- Hydraulic presses
- Marine applications
- Industrial plants
- Assembly production
- Mining and tunnel boring machines



Variable displacement axial piston pump type V30D

2 Available versions

Circuit symbol

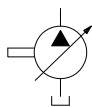

Ordering example

V30D-075	R	K	G	N	-1	-0	-02	/NL	-2	/65	-350
											Pressure setting (nominal pressure) (bar)
											Torque setting (Nm)
											2.9 "Stroke limitation"
											<ul style="list-style-type: none"> 2.8 "Controller" 2.8.5 "Solenoid voltage and solenoid version"
											Manufacturing series
											2.7 "Swivel angle indicator"
											2.6 "Thru-shaft"
											2.5 "Seals"
											2.4 "Flange versions (input side)"
											2.3 "Shaft journal"
											2.2 "Rotation direction"
											2.1 "Basic type and nominal size"

2.1 Basic type and nominal size

Type	Displacement volume V_{max} (cm ³ /rev)	Nominal pressure $p_{nom max}$ (bar)	Peak pressure p_{max} (bar)
V30D-045	45	350	420
V30D-075	75	350	420
V30D-095	96	350	420
V30D-115	115	250 *	300 *
V30D-140	142	350	420
V30D-160	164	250 *	300 *
V30D-250	250	350	420

* Higher pressures are possible with reduced geometric displacement.

2.2 Rotation direction

Coding	Description
L	Anti-clockwise
R	Clockwise
B	Any (only V30D-075, V30D-095, V30D-115, V30D-140, V30D-160, V30D-250)

When looking at the shaft journal.

2.3 Shaft journal

Coding	Description	Designation / standard	Size	Max. drive torque (Nm)
D	Spline shaft	W35x2x16x9g / DIN 5480	V30D-045	550
		W40x2x18x9g / DIN 5480	V30D-075	910
			V30D-095/115	1200
		W50x2x24x9g / DIN 5480	V30D-140/160	1700
		W60x2x28x9g / DIN 5480	V30D-250	3100
K	Parallel key shaft	Ø35 - AS10x8x56 / DIN 6885	V30D-045	280
		Ø40 - AS12x8x70 / DIN 6885	V30D-075	460
		Ø40 - AS12x8x80 / DIN 6885	V30D-095/115	650
		Ø50 - AS14x9x80 / DIN 6885	V30D-140/160	850
		Ø60 - AS18x11x100 / DIN 6885	V30D-250	1550
S	Spline shaft	<ul style="list-style-type: none"> ▪ SAE-C J744 / SAE J 744 ▪ 14T 12/24 DP ▪ 32-4 / DIN ISO 3019-1 	V30D-045/075	500
		<ul style="list-style-type: none"> ▪ SAE-D J744 / SAE J 744 ▪ 13T 8/16 DP ▪ 44-4 / DIN ISO 3019-1 	V30D-095/115/140/160	1200
U	Spline shaft	<ul style="list-style-type: none"> ▪ SAE-D J744 / SAE J 744 ▪ 13T 8/16 DP ▪ 44-4 / DIN ISO 3019-1 	V30D-250	1200

2.4 Flange versions (input side)

Coding	Description	Designation / standard	Size
G	Flange	125 B4 HW / DIN ISO 3019-2	V30D-045
		140 B4 HW / DIN ISO 3019-2	V30D-075
		160 B4 HW / DIN ISO 3019-2	V30D-095/115
		180 B4 HW / DIN ISO 3019-2	V30D-140/160/250
F	Flange	<ul style="list-style-type: none"> ▪ SAE-C 4-hole J744 / SAE J 744 ▪ 127-4 / DIN ISO 3019-1 	V30D-045/075
		<ul style="list-style-type: none"> ▪ SAE-D 4-hole J744 / SAE J 744 ▪ 152-4 / DIN ISO 3019-1 	V30D-095/115/140/160
W	Flange	<ul style="list-style-type: none"> ▪ SAE-D 4-hole J744 / SAE J 744 ▪ 152-4 / DIN ISO 3019-1 	V30D-250

2.5 Seals

Coding	Description
N	NBR
V	FKM
E	EPDM
C	NBR, suitable for HFC, for restrictions see Chapter 5, "Installation, operation and maintenance information"

2.6 Thru-shaft

Coding	Description
1	Without thru-shaft, suction port 45°
2	With thru-shaft, suction port 45°

2.7 Swivel angle indicator

Coding	Description
0	without display
1	with display
2	With swivel angle sensor 0.5 - 4.5 V
3	With display and swivel angle sensor 4 - 20 mA
4	With swivel angle sensor 4 - 20 mA
5	With display and swivel angle sensor 0.5 - 4.5 V

2.8 Controller

Load-sensing controller

Coding	Description
LS	Load-sensing controller
LSN, LSNw	Load-sensing controller with integrated pressure limitation
LSP	Load sensing controller with remote-control port for external pressure limitation
LSD	Load sensing controller without integrated pressure limitation for parallel operation of multiple pumps

Pressure controller

Coding	Description
N, Nw	Pressure controller
ND, NDw	Pressure controller with special piston for higher signal resolution. Specially designed for larger systems with long pipes and hose lines.
P	Pressure controller with remote-control port for external pilot valve
Pb	Pressure controller with remote-control port for external pilot valve. Specifically for extremely vibration-prone applications.
PD5	Parallel pressure controller for external pilot valve. For multiple pumps with the same consumer.

Power controller

Coding	Description
L, Lw	Power controller with fixed setting value
Lf	Hydraulically adjustable power controller with increasing characteristic curve
Lf1	Hydraulically adjustable power controller with decreasing characteristic curve

Delivery flow controller

Coding	Description
Q	Flow controller for setting a constant flow rate independently of the speed.
Qb	Flow controller for setting a constant flow rate independently of the speed, for applications with high demands on accuracy
V	Electro-proportional delivery flow controller with increasing characteristic curve
VH	Hydraulic delivery flow controller with increasing characteristic curve.

Structure

V30D-045/075/140/160

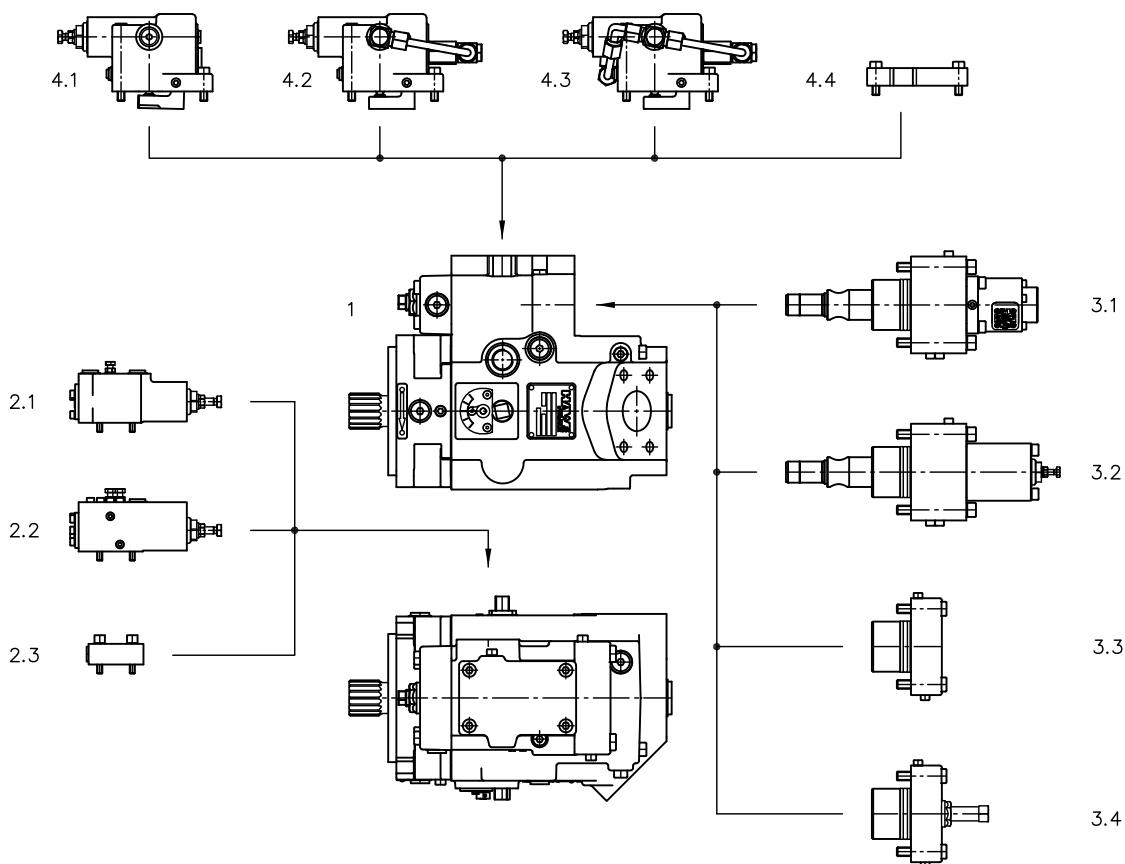

- 1 Basic pump
- 2.1 Controller type N, P, Pb, LS, Q, Qb
- 2.2 Controller type LSN, LSP
- 2.3 Cover for version without N, P, Pb, LS, LSN, LSP, Q, Qb
- 3.1 Controller type V
- 3.2 Controller type VH
- 3.3 Cover for version without V or VH, without stroke limitation
- 3.4 Cover for version without V or VH, with stroke limitation (045: 5 cm³/rev, 075: 6.6 cm³/rev, 140: 10.5 cm³/rev, 160: 10.7 cm³/rev)
- 4.1 Controller type L, Lf1
- 4.2 Controller type LSD
- 4.3 Controller type PD5
- 4.4 Cover for version without L, Lf1, LSD, PD5

V30D-095/115

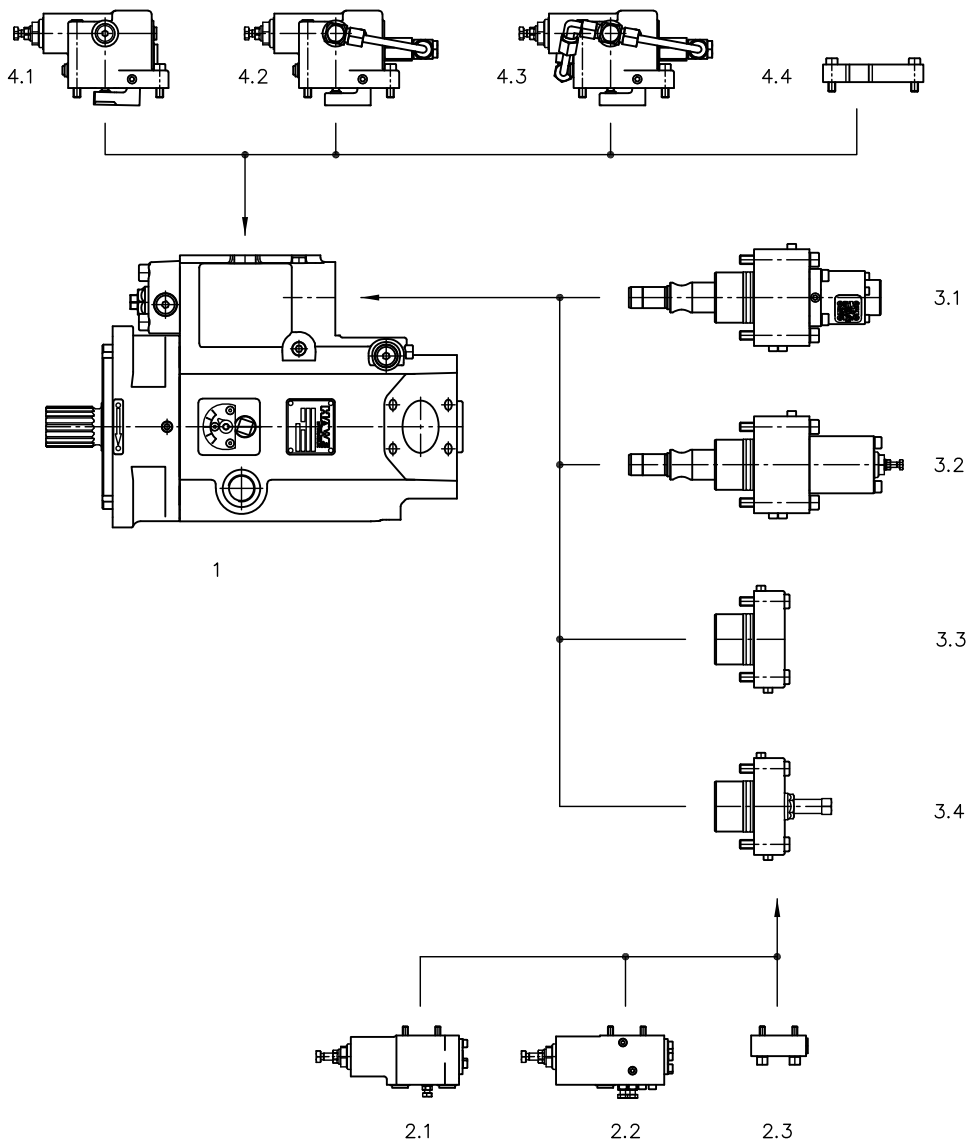

- 1 Basic pump
- 2.1 Controller type N, P, Pb, LS, Q, Qb
- 2.2 Controller type LSN, LSP
- 2.3 Cover for version without N, P, Pb, LS, LSN, LSP, Q, Qb
- 3.1 Controller type V
- 3.2 Controller type VH
- 3.3 Cover for version without V or VH, without stroke limitation
- 3.4 Cover for version without V or VH, with stroke limitation (095: 8.2 cm³/rev, 115: 8.4 cm³/rev)
- 4.1 Controller type L, Lf1
- 4.2 Controller type LSD
- 4.3 Controller type PD5
- 4.4 Cover for version without L, Lf1, LSD, PD5

V30D-250

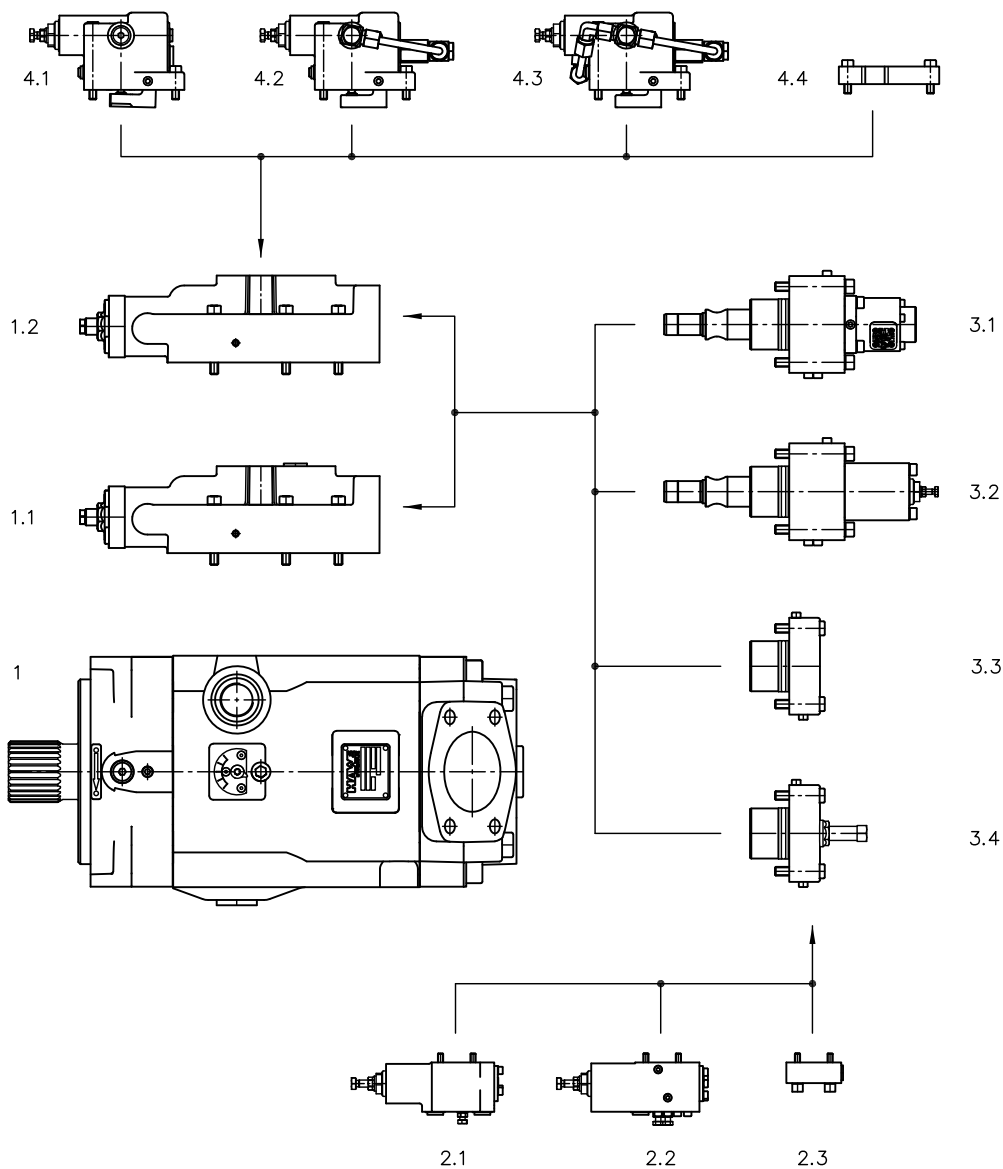

- 1 Basic pump
- 1.1 Control head without L, Lf1, LSD, PD5 (series)
- 1.2 Control head for L, Lf1, LSD, PD5
- 2.1 Controller type N, P, Pb, LS, Q, Qb
- 2.2 Controller type LSN, LSP
- 2.3 Cover for version without N, P, Pb, LS, LSN, LSP, Q, Qb
- 3.1 Controller type V
- 3.2 Controller type VH
- 3.3 Cover for version without V or VH, without stroke limitation
- 3.4 Cover for version without V or VH, with stroke limitation(16.2 cm³/rev)
- 4.1 Controller type L, Lf1
- 4.2 Controller type LSD
- 4.3 Controller type PD5
- 4.4 Cover for version without L, Lf1, LSD, PD5

2.8.1 Load sensing controller LS, LSN, LSP, LSD

The LS (N, P, D) controller is a flow controller that generates a variable flow rate independently of the speed. It adapts the geometric displacement of the pump to the required flow rate of the consumer and regulates a constant difference between load pressure and pump pressure.

The LSD controller is used if several pumps supply the same consumer. It regulates the same geometric displacement on all pumps.

LS

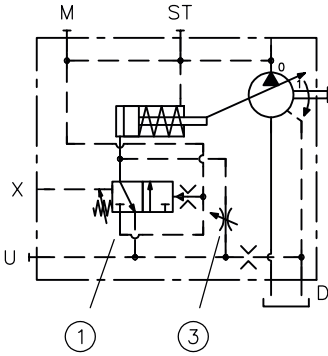

LSN

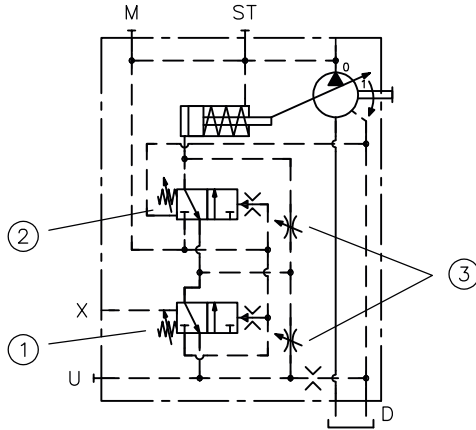

LSP

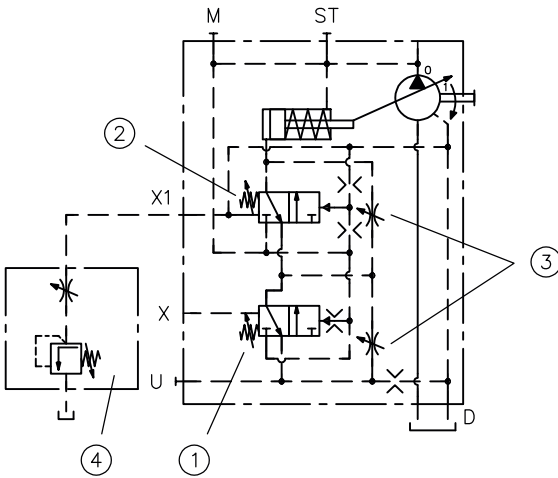

LSD

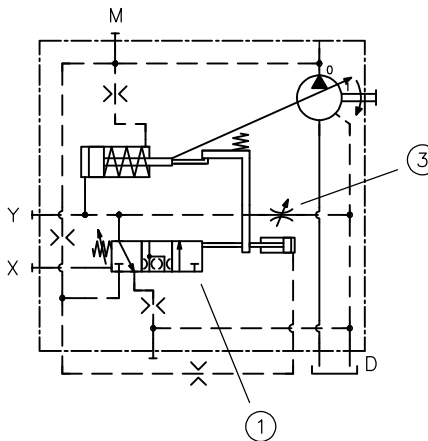

- 1 Flow controller: Regulates a constant difference between load pressure and pump pressure
- 2 Pressure limitation: Limits the pump pressure to a maximum value
- 3 Bypass throttle
- 4 External pressure-limiting valve (not included in scope of delivery)

Characteristic lines

LS, LSN, LSNw, LSP

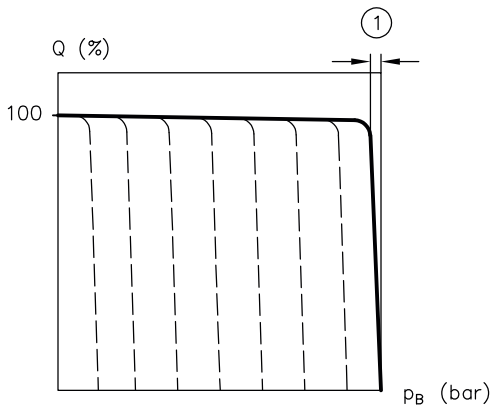

p_B operating pressure (bar); Q delivery flow (%)

1 Approx. 3 bar

LSD

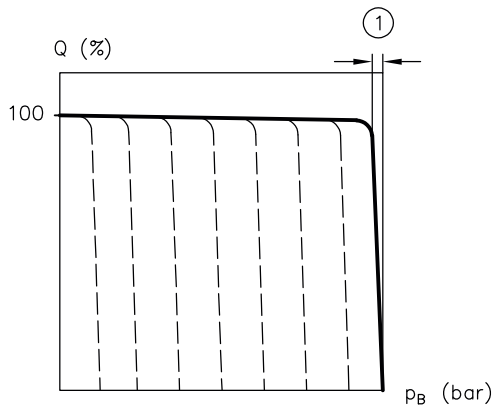

p_B operating pressure (bar); Q delivery flow (%)

1 Approx. 12 bar

Structure

LS

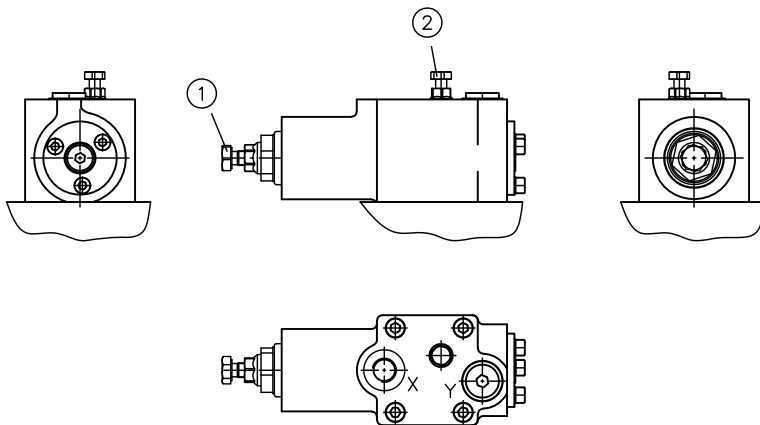

- 1 Differential pressure Δp (stand-by pressure)
- 2 Bypass throttle

LSN, LSP

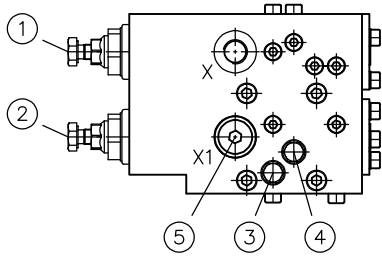
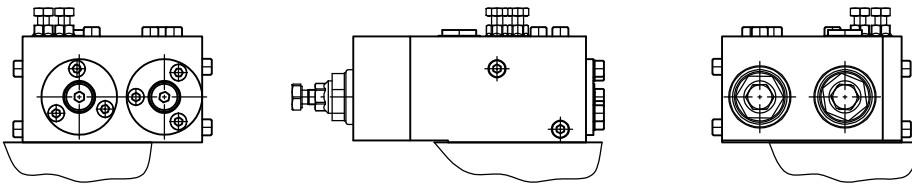

- 1 Differential pressure Δp (stand-by pressure)
- 2 Maximum pressure p_{max} (pressure limitation)
- 3 Bypass throttle LS
- 4 Bypass throttle N
- 5 For coding LSN with tapped plug closed

LSD

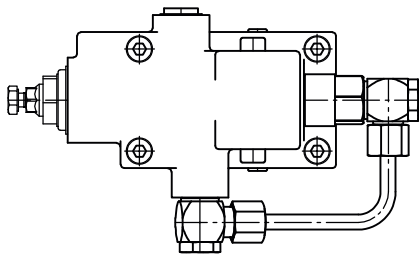
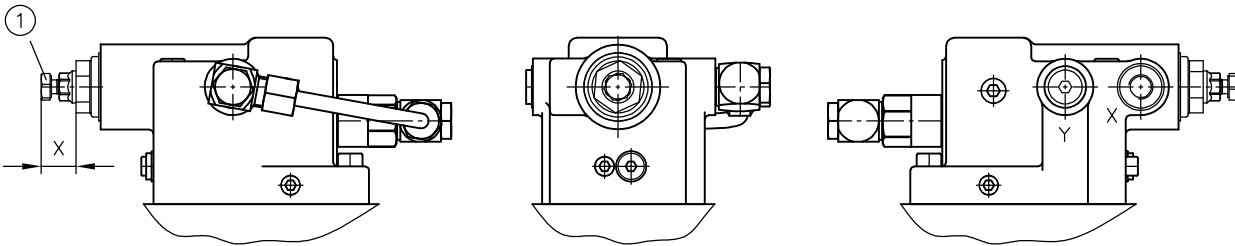

- 1 Differential pressure Δp (stand-by pressure)

Pressure adjustment	Pressure range (bar)	Δp (bar)/revolution	Factory-set pressure setting (bar)
Maximum pressure p_{\max} (LSNw)	50 ... 200	approx. 50	200
Maximum pressure p_{\max} (LSN)	100 ... 350	approx. 100	300
Differential pressure Δp (P)	12 ... 60	approx. 15	15
Differential pressure Δp (LS)	20 ... 60	approx. 15	30

 **CAUTION**

Overloading components due to incorrect pressure settings.

Risk of minor injury.

- Always monitor with a pressure gauge when setting and changing the pressure.
- Take note of the maximum pressure of the pump.

 **NOTICE**

Loosen the lock nut sufficiently before setting so that the sealing ring is not damaged.

2.8.2 Pressure controller N, Nw, ND, NDw, P, Pb, PD5

The N, Nw, ND, NDw, P, Pb and PD5 controllers are pressure controllers. As soon as the pump pressure exceeds the set value, they reduce the swivel angle of the pump and regulate a constant pressure level.

The PD5 controller is used if several pumps supply the same consumer. It regulates the same geometric displacement on all pumps. The pressure setting takes place via an external pilot valve connected to the controllers via a control ports.

Depending on the controller type, the pressure setting takes place either via a setting screw directly on the controller or via an external pilot valve.

The pressure controllers can either be used in constant pressure systems or as low-loss pressure limitation in combination with a flow controller (e.g. type V or VH).

N, Nw, ND, NDw

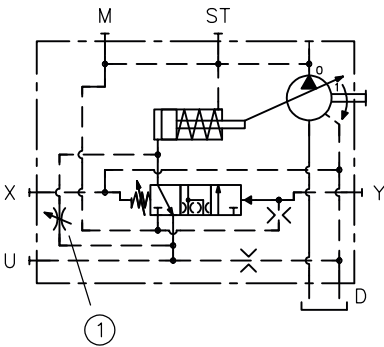

P

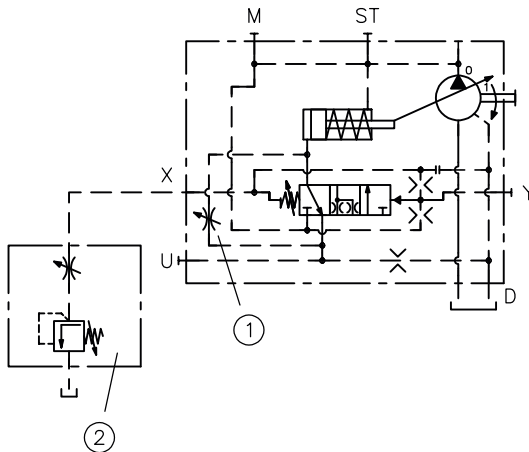

Pb

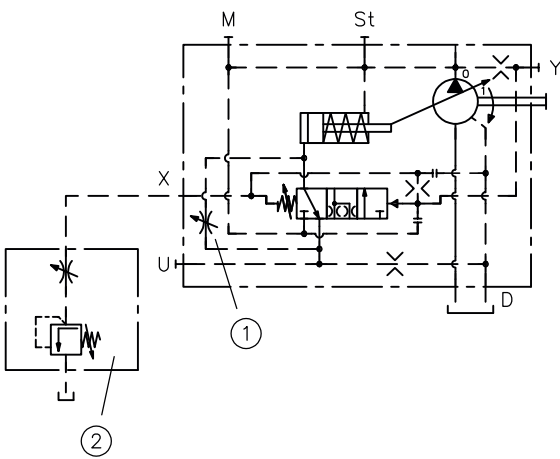

PD5

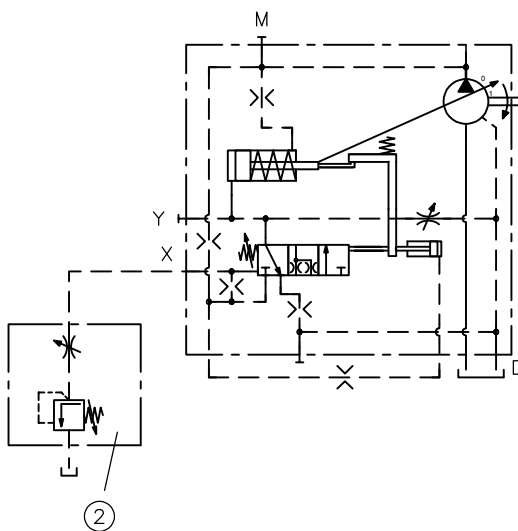

- 1 Bypass throttle
- 2 External pressure-limiting valve (not included in scope of delivery)

Characteristic lines

N, Nw, ND, NDw, P, Pb

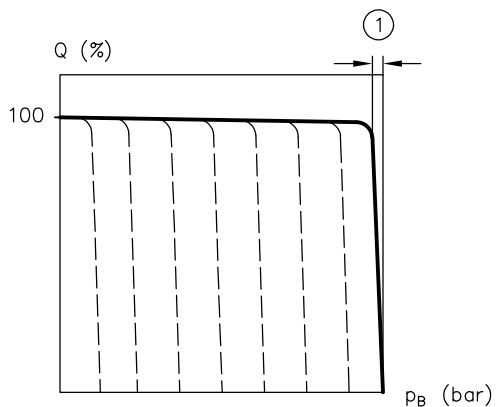

1 Approx. 3 bar

PD5

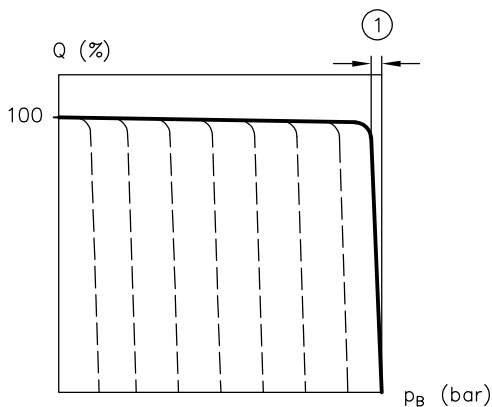

1 Approx. 12 bar

Structure

N, Nw, ND, NDw, P, Pb

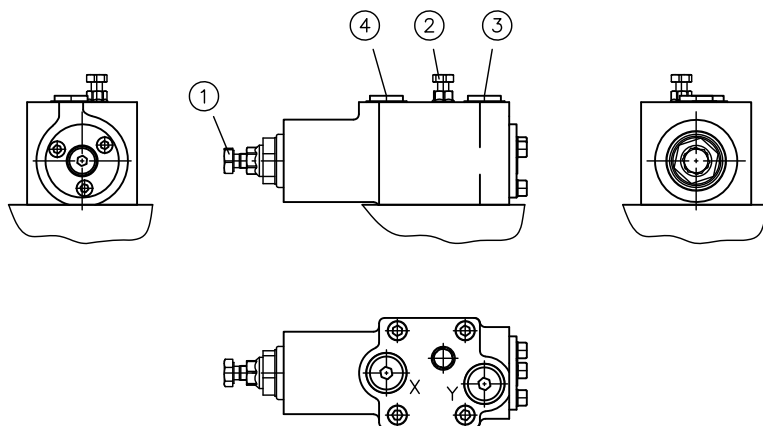

- 1 Pressure setting p
- 2 Bypass throttle
- 3 Y-port: For coding N and P with tapped plug closed
- 4 X port: For coding N with tapped plug closed

PD5

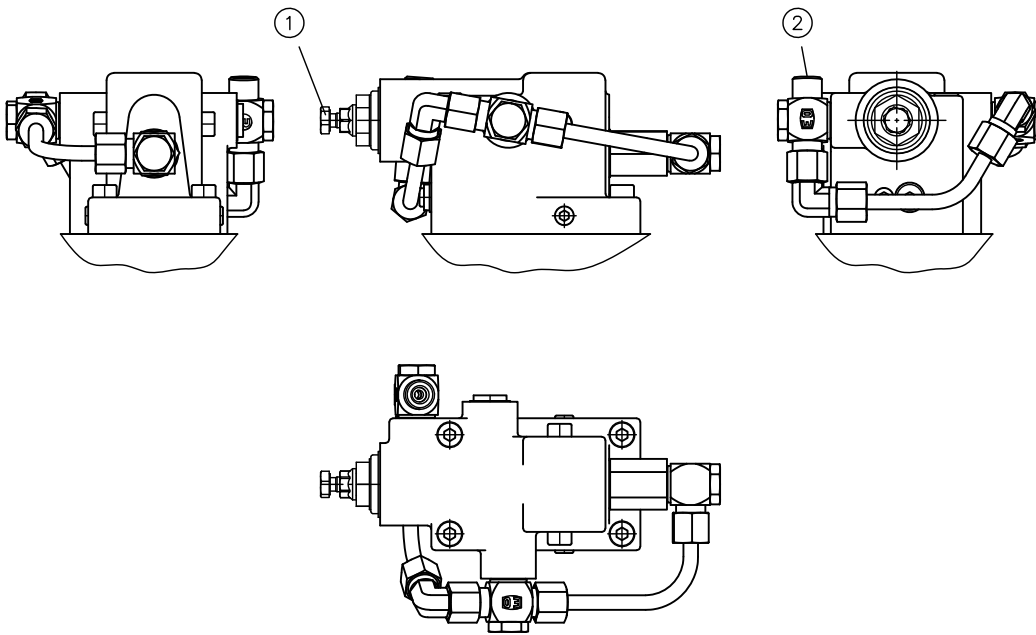

- 1 Pressure setting p
- 2 X port

Pressure adjustment	Pressure range (bar)	Δp (bar)/revolution	Factory-set pressure setting (bar)
Nw, NDw	50 ... 200	approx. 50	200
N, ND	100 ... 350	approx. 100	300
P, Pb, PD5	--	approx. 15	15

⚠ CAUTION
Overloading components due to incorrect pressure settings.
 Risk of minor injury.

- Always monitor with a pressure gauge when setting and changing the pressure.
- Take note of the maximum pressure of the pump.

! NOTICE
 Loosen the lock nut sufficiently before setting so that the sealing ring is not damaged.

2.8.3 Power controller L, Lw, Lf, Lf1

The L, Lw, Lf and Lf1 controllers are power controllers. As soon as the product of the displacement volume and pressure exceeds the set value, the controller reduces the swivel angle of the pump to protect the drive shaft or gearbox from overload ($p_B \times V_g = \text{constant}$).

The setting is made either as a torque limitation (Nm) or power limitation (kW) at the corresponding rotation speed (min⁻¹).

- Drive torque

$$M = \frac{V_g \cdot \Delta p}{20 \cdot \pi \cdot \eta_{mh}} \text{ (Nm)}$$

- Drive power

$$P = \frac{2\pi \cdot M \cdot n}{60000} = \frac{Q \cdot \Delta p}{600 \cdot \eta_t} \text{ (kW)}$$

M = Torque (Nm)

V_g = Geometric delivery volume (cm³/rev)

Δp = Differential pressure

p_B = Operating pressure

P = Power (kW)

Q = Flow rate (l/min)

n = Rotation speed (min⁻¹)

η_v = Volumetric efficiency

η_{mh} = Mechanical-hydraulic efficiency

η_T = Overall efficiency (η_T = η_v * η_w)

L, Lw

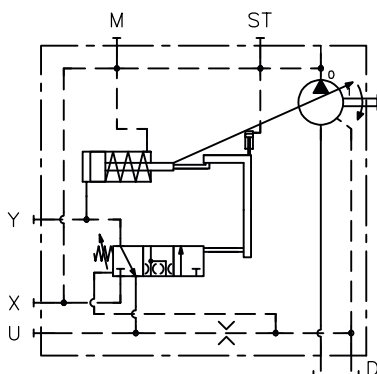

Lf

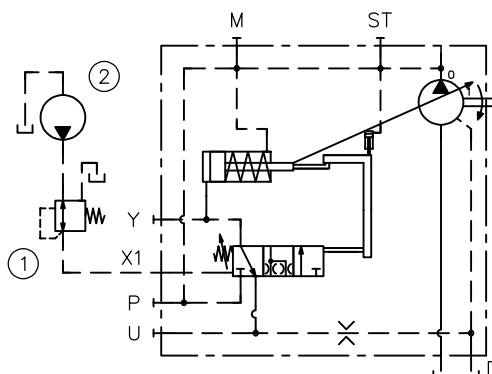

Lf1

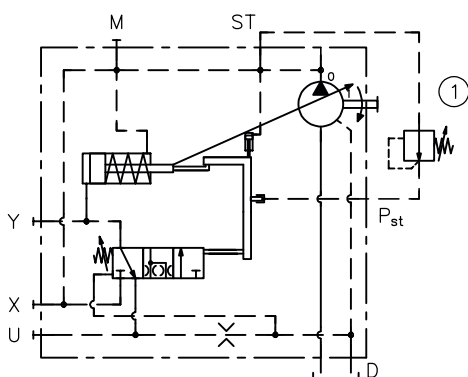

- 1 External pressure reducing valve (not included in scope of delivery)
- 2 External auxiliary pump (not included in scope of delivery)

Characteristic lines

L, Lf, Lf1

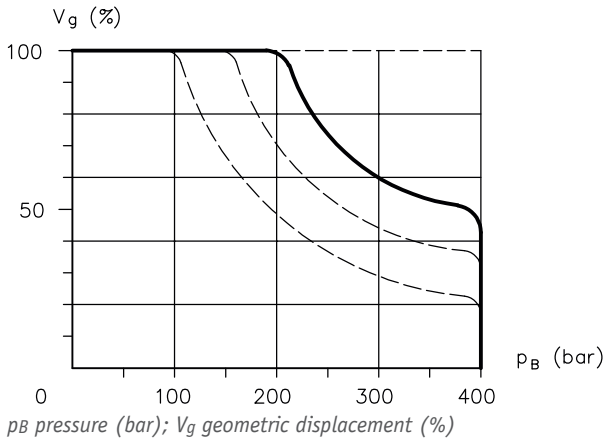

For low nominal torques, the special Lw power controller version designed for low power is used. The nominal torques for the regular and special versions are listed below.

Coding	Nm	kW / 1500 min ⁻¹	
045	Lw	40 - 73	6 - 11
	L	74 ...	12 ...
075	Lw	70 - 119	11 - 18
	L	120 ...	19 ...
095	Lw	99 - 178	15 - 27
	L	179 ...	28 ...
115	Lw	119 - 165	18 - 25
	L	166 ...	26 ...
140	Lw	146 - 217	22 - 33
	L	218 ...	34 ...
160	Lw	198 - 250	30 - 38
	L	251 ...	39 ...
250	Lw	271 - 389	41 - 59
	L	390 ...	60 ...

Lf1

Rough reference values for remote setting of the Lf1 controller

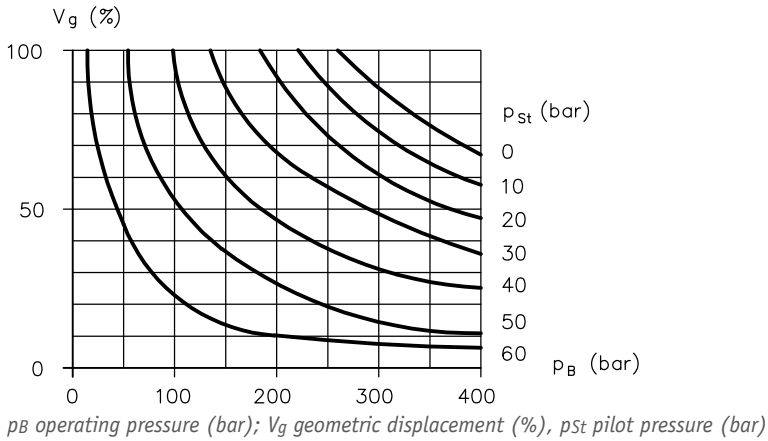

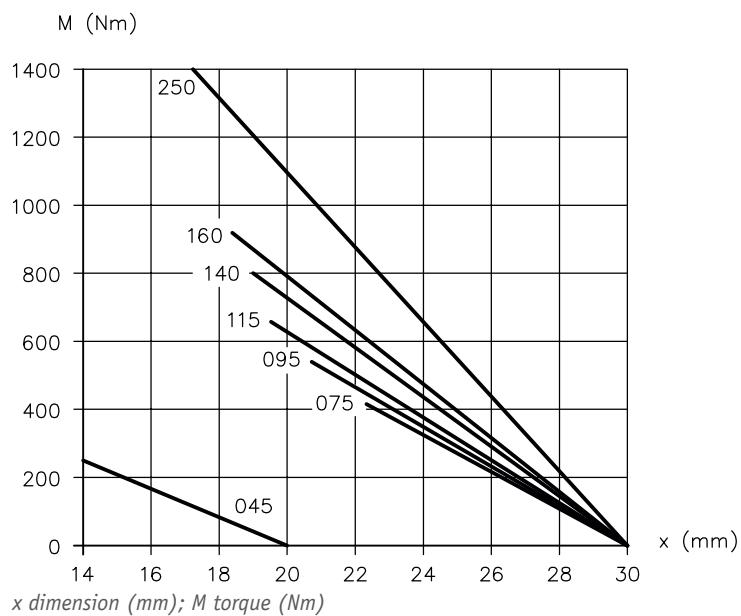

NOTICE

Loosen the lock nut sufficiently before setting so that the sealing ring is not damaged.

Structure

L

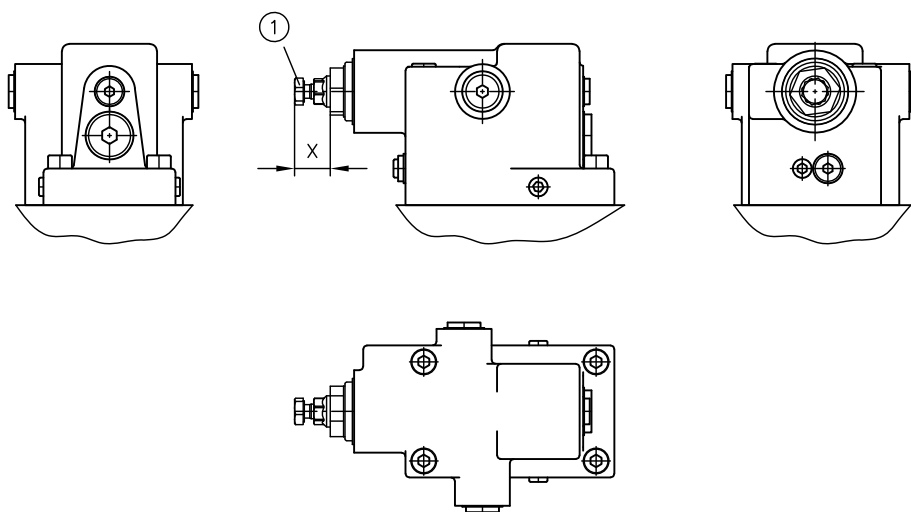

1 Torque setting

Lf, Lf1

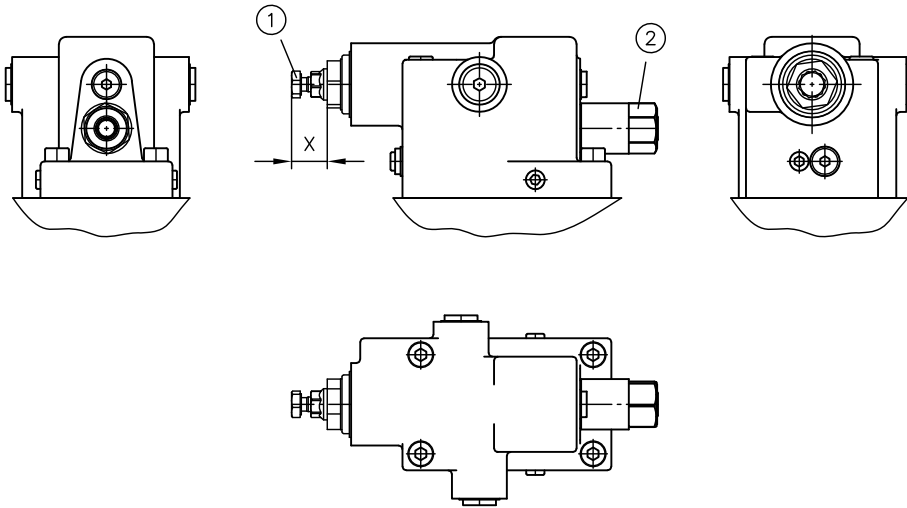

- 1 Differential pressure Δp (stand-by pressure)
- 2 pSt port

2.8.4 Delivery flow controller

Q, Qb

The Q(b) controller is a flow controller that generates a constant flow rate independently of the speed. It regulates a constant differential pressure via an orifice in the P channel. The differential pressure can be set between 15 and tbd bar; the orifice is available in different graduations (see table). The Qb controller is a version with external signalling of the pump pressure to compensate for a pressure loss in the P line. For use in hydrostatic applications with high demands on the speed consistency, e.g. generator drives.

Q

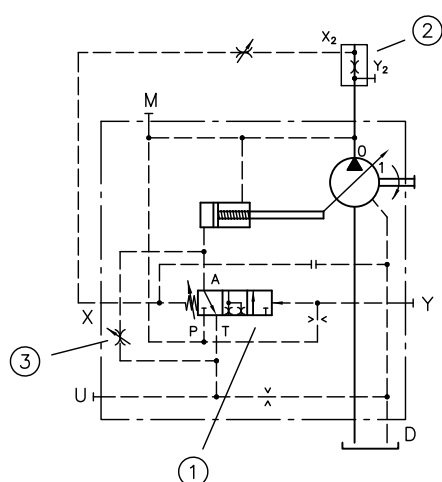

Qb

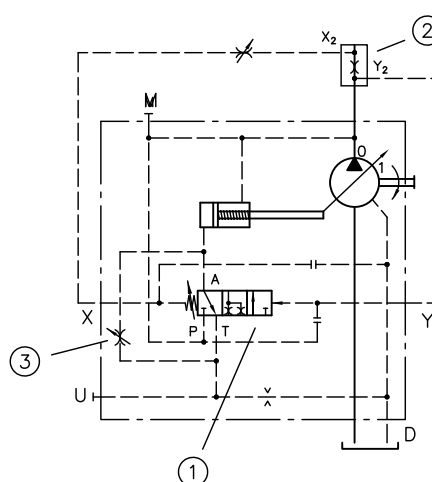

- 1 Flow controller: Regulates a constant differential pressure before and after the orifice
- 2 Orifice: Selection based on the table (not included in the scope of supply)
- 3 Bypass throttle

Orifice Ø (mm)	Flow rate (l/min) at 20 bar differential pressure
3	23
3.5	32
4	42
4.5	53
5	65
5.5	79
6	94
6.5	110
7	127
7.5	146
8	166
8.5	188
9	210
9.5	234
10	260

Characteristic lines

Q, Qb

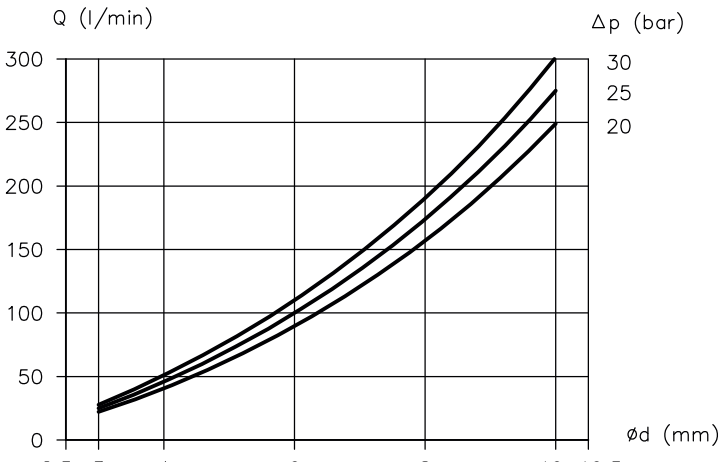

Ød orifice diameter (mm); Q flow rate (l/min); Δp pressure difference (bar)

Determination of the flow rate

$$Q = 0,55 \cdot d^2 \sqrt{\Delta p}$$

Structure

Coding Q, Qb

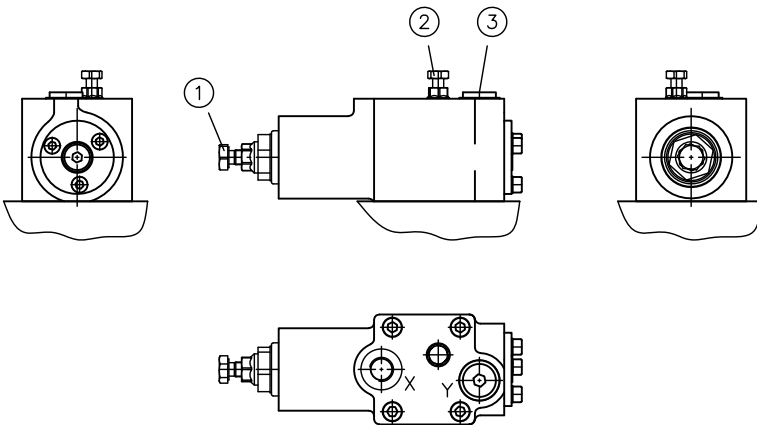

- 1 Differential pressure Δp (stand-by pressure)
- 2 Bypass throttle
- 3 Y-port. For coding Q with tapped plug closed With coding Qb pressure signal port before the orifice.

Pressure adjustment	Pressure range (bar)	Δp (bar)/revolution	Factory-set pressure setting (bar)
Differential pressure Δp	10 ... 25	approx. 15	15

NOTICE

Loosen the lock nut sufficiently before setting so that the sealing ring is not damaged.

V, VH

The V and VH controllers are proportional flow controllers that generate a variable, speed-dependent flow rate. They adjust the geometric displacement of the pump based on an electrical or hydraulic input signal. The resulting flow rate depends on the displacement volume and speed.

The required pilot pressure for adjusting the swivel angle is tapped internally. When used in open centre systems with operating pressures of < 25 bar, an external auxiliary pump or a pre-load valve must be provided to ensure reliable adjustment.

V

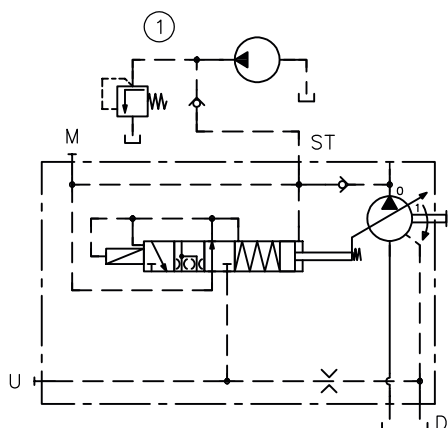

VH

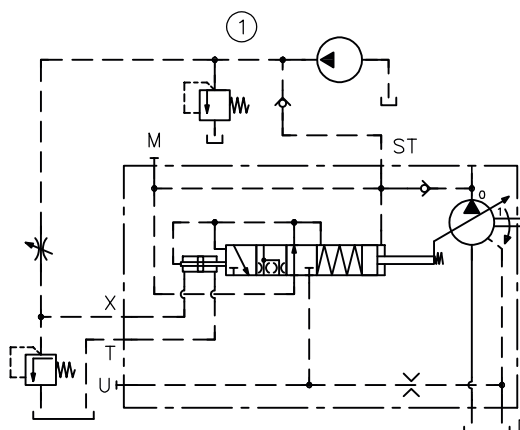

1 External auxiliary pump, pressure-limiting valve and check valve (not included in scope of delivery)

V

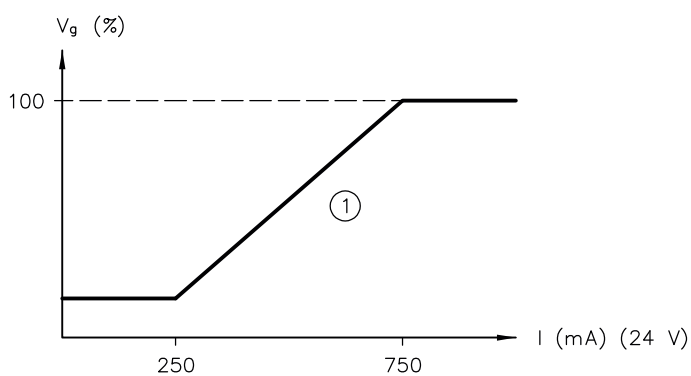

I current (mA); V_g displacement volume (%)

1 Hysteresis approx. 2%

VH

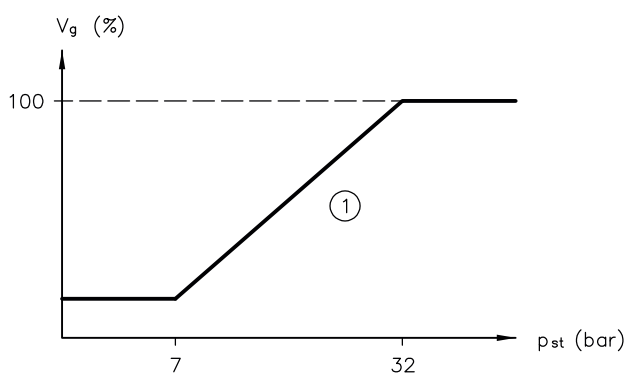

p_{st} pilot pressure (bar); V_g geometric displacement (%)

1 Hysteresis approx. 4%

NOTICE

- $Q = 0$ l/min possible due to use of auxiliary pump.
- At $V_g = 0$ cm³/rev flushing via the drain port is also required to guarantee sufficient lubrication of the pump.
- Recommended flow rate: 2 l/min (V30D-045/075), 3 l/min (V30D-095/115), 4 l/min (V30D-140/160) or 5 l/min (V30D-250)

Response time

l / p_{st} (bar)

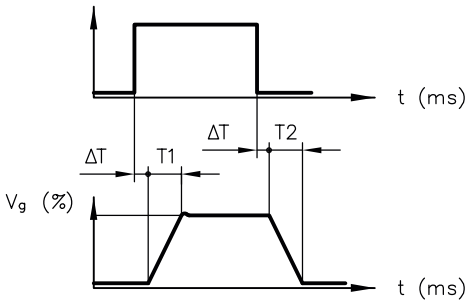

ΔT = Delay

T1 = On-stroke time 0 to max.

T2 = On-stroke time max. to 0

Characteristic lines

V, VH

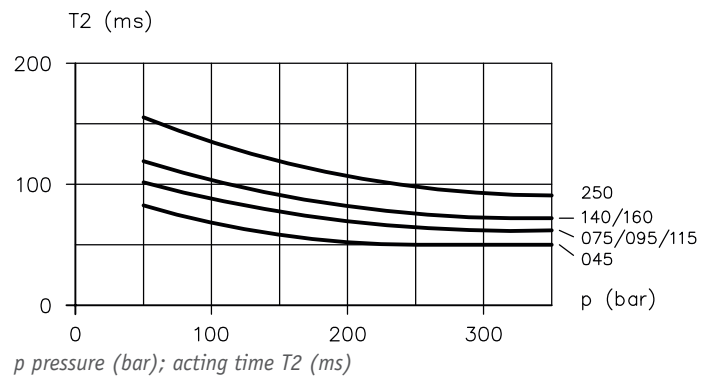
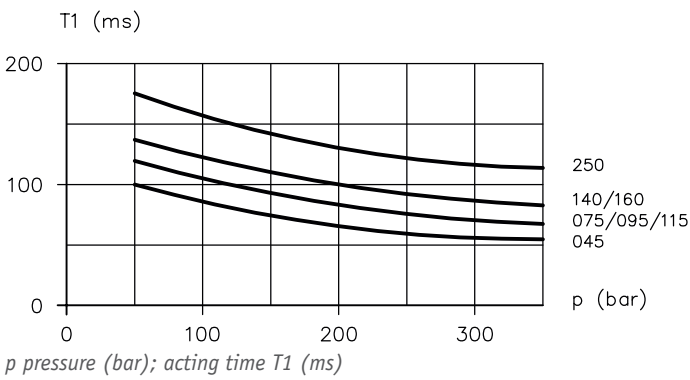

Structure

Coding VH

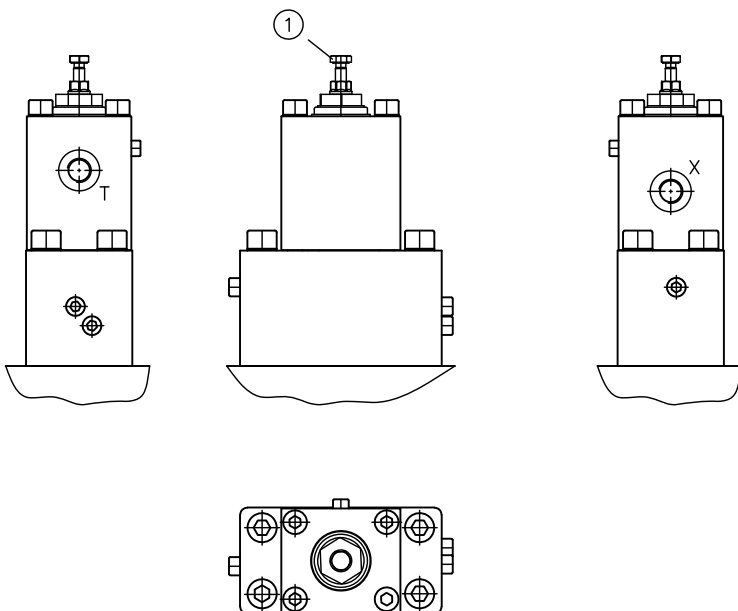

1 Stroke limitation control valve

Coding V

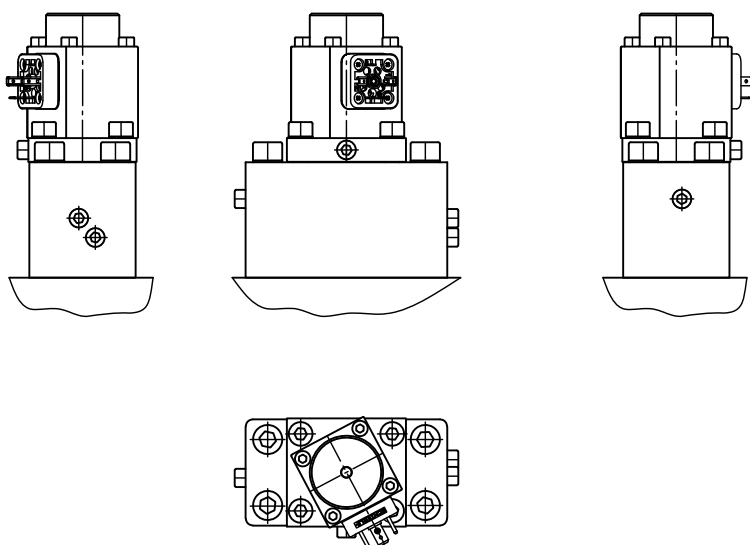

2.8.5 Solenoid voltage and solenoid version

Coding	Electrical connection	Nominal voltage	Protection class (IEC 60529)
V/12	EN 175 301-803 A	12 V DC	IP 65
V/24		24 V DC	

2.9 Stroke limitation

Coding	Description
without coding	Without stroke limitation
1	Prepared for power controller
2	Stroke limitation adjustable (not possible in combination with pump controller type V, VH)
2/...	Stroke limitation fixed with specification of displacement volume V_g (cm ³ /rev)

2.10 Flange version (output side)

Ordering example

V30D-075 RDGN-2-0-02/LSN-350 - C 426

Coding V30D						Flange	Shaft
045	075	095	115	140/160	250		
C 411	C 421	C 431	C 441	C 451/C 461	C 471	SAE-A 2-hole J744 82-2 DIN ISO 3019-1	SAE-A J744 (16-4 DIN ISO 3019-1) 9T 16/32 DP
C 412	C 422	C 432	C 442	C 452/C 462	C 472	SAE-A 2-hole J744 82-2 DIN ISO 3019-1	SAE-A J744 (16-4 DIN ISO 3019-1) * 9T 16/32 DP
C 413	C 423	C 433	C 443	C 453/C 463	C 473	SAE-A 2-hole J744 82-2 DIN ISO 3019-1	SAE-A J744 (19-4 DIN ISO 3019-1) 11T 16/32 DP
C 414	C 424	C 434	C 444	C 454/C 464	C 474	SAE-B 2-hole J744 101-2 DIN ISO 3019-1	SAE-B J744 (22-4 DIN ISO 3019-1) 13T 16/32 DP
C 415	C 425	C 435	C 445	C 455/C 465	C 475	SAE-B 4-hole J744 101-4 DIN ISO 3019-1	SAE-B J744 (22-4 DIN ISO 3019-1) 13T 16/32 DP
C 416	C 426	C 436	C 446	C 456/C 466	C 476	SAE-B 2-hole J744 101-2 DIN ISO 3019-1	SAE-BB J744 (25-4 DIN ISO 3019-1) 15T 16/32 DP
C 417	C 427	C 437	C 447	C 457/C 467	C 477	SAE-C 2-hole J744 127-2 DIN ISO 3019-1	SAE-C J744 (32-4 DIN ISO 3019-1) 14T 12/24DP
C 418	C 428	C 438	C 448	C 458/C 468	C 478	SAE-C 4-hole J744 127-4 DIN ISO 3019-1	SAE-C J744 (32-4 DIN ISO 3019-1) 14T 12/24 DP
C 419	C 429	C 439	C 449	C 459/C 469	C 479	SAE-C 2-hole J744 127-2 DIN ISO 3019-1	SAE-CC J744 (38-4 DIN ISO 3019-1) 17T 12/24 DP
--	--	C 440	C 450	C 460/C 470	C 480	SAE-D 4-hole J744 152-4 DIN ISO 3019-1	SAE-D J744 (44-4 DIN ISO 3019-1) 13T 8/16 DP
C 500	C 501	C 503	C 506	C 510/C 515	C 521	125 B4 HW DIN ISO 3019-2	W35x2x16x9g (DIN 5480)
--	C 502	C 504	C 507	C 511/C 516	C 522	140 B4 HW DIN ISO 3019-2	W40x2x18x9g (DIN 5480)
--	--	C 505	C 509	C 512/C 517	C 523	160 B4 HW DIN ISO 3019-2	W40x2x18x9g (DIN 5480)
--	--	--	--	C 514/C 520	C 525	180 B4 HW DIN ISO 3019-2	W50x2x24x9g (DIN 5480)
--	--	--	--	--	C 527	180 B4 HW DIN ISO 3019-2	W60x2x28x9g (DIN 5480)

* ANSI B 92.1, FLAT ROOT SIDE FIT spline width deviating from standard, $s = 2.357 - 0.03$

! NOTICE

Pay attention to the maximum permissible drive torque, as the flange or shaft may be damaged otherwise.

! NOTICE

An additional support is to be provided for pump combinations.

3 Parameters

3.1 General data

Designation	Variable displacement axial piston pump					
Pump version	Axial piston pump according to the swash plate principle					
Mounting	Mounting flange according to DIN ISO 3019-1 or DIN ISO 3019-2					
Surface	primed					
Drive/output torque	Nominal size					
		045	075	095 / 115	140 / 160	250
	Spline shaft D	550 / 275	910 / 455	1200 / 600	1700 / 850	3100 / 1550
	Parallel key K	280	460	650	850	1550
	Spline shaft S	500 / 272	500 / 445	1200 / 600	1200 / 850	1200 / 1000
Installation position	any Installation information see Chapter 5, "Installation, operation and maintenance information"					
Rotation direction	<ul style="list-style-type: none"> ▪ right ▪ left 					
Ports/connections	<ul style="list-style-type: none"> ▪ Suction port ▪ Pressure connection ▪ Drain port ▪ Pressure gauge connection 					
Hydraulic fluid	Hydraulic fluid, according to DIN 51524 Parts 1 to 3; ISO VG 10 to 68 according to DIN ISO 3448 Viscosity range: 10 - 1000 mm ² /s Optimal operating range: approx. 16 - 60 mm ² /s Also suitable for biologically degradable hydraulic fluids type HEPG (polyalkylene glycol) and HEES (synthetic ester) at operating temperatures up to approx. +70°C.					
Cleanliness level	ISO 4406 20/18/15					
Temperatures	Environment: approx. -40 to +60 °C, hydraulic fluid: -25 to +80 °C, pay attention to the viscosity range. Start temperature: down to -40 °C is permissible (take account of the start viscosities!), as long as the steady-state temperature is at least 20 K higher during subsequent operation. Biologically degradable hydraulic fluids: note manufacturer specifications. With consideration for the seal compatibility, not above +70°C.					

Designation	Nominal size						
	045	075	095	115	140	160	250
Max. swash plate angle	17°	17.5°	17°	20°	17.5°	20°	17.5°
Absolute inlet pressure required in open circuit	0.8 bar	0.85 bar	0.85 bar	0.85 bar	0.85 bar	0.85 bar	0.85 bar
Max. permissible housing pressure (static/dynamic)	1 / 2 bar	1 / 2 bar	1 / 2 bar	1 / 2 bar	1 / 2 bar	1 / 2 bar	1 / 2 bar
Max. permissible inlet pressure	25 bar	25 bar	25 bar	25 bar	25 bar	25 bar	25 bar
Max. rotation speed during suction operation and max. swash plate angle at 1 bar abs. Inlet pressure	2600 min ⁻¹	2400 min ⁻¹	2200 min ⁻¹	2000 min ⁻¹	2200 min ⁻¹	1900 min ⁻¹	1800 min ⁻¹
Max. rotation speed with zero stroke and 1 bar abs. Inlet pressure	3600 min ⁻¹	3200 min ⁻¹	2900 min ⁻¹	2800 min ⁻¹	2600 min ⁻¹	2500 min ⁻¹	2000 min ⁻¹
Min. rotation speed in continuous operation	500 min ⁻¹	500 min ⁻¹	500 min ⁻¹	500 min ⁻¹	500 min ⁻¹	500 min ⁻¹	500 min ⁻¹
Required drive torque at 100 bar	77 Nm	128 Nm	164 Nm	197 Nm	240 Nm	275 Nm	430 Nm
Drive power at 250 bar and 1450 min ⁻¹	30 kW	50 kW	64 kW	77 kW	95 kW	109 kW	174 kW
Inertia torque	0.0056 kg m ²	0.0124 kg m ²	0.0216 kg m ²	0.0216 kg m ²	0.03 kg m ²	0.03 kg m ²	0.0825 kg m ²
Service life L ₁₀ of the shaft bearing at 250 bar, 1450 min ⁻¹ and max. swash plate angle	31000 h	20000 h	17000 h	10000 h	17000 h	10000 h	23000 h
Noise level at 250 bar, 1450 min ⁻¹ and max. swash plate angle (measured in acoustic measurement chamber according to DIN ISO 4412-1 with measuring distance 1 m)	72 dB(A)	74 dB(A)	75 dB(A)	75 dB(A)	76 dB(A)	76 dB(A)	77 dB(A)

3.2 Weight

Type	Without controller	With controller
V30D-045	= 40 kg	+ 6 kg
V30D-075	= 60 kg	+ 6 kg
V30D-095	= 70 kg	+ 6 kg
V30D-115	= 70 kg	+ 6 kg
V30D-140	= 85 kg	+ 6 kg
V30D-160	= 85 kg	+ 6 kg
V30D-250	= 130 kg	+ 6 kg

3.3 Pressure and delivery flow

Operating pressure	see Chapter 2.1, "Basic type and nominal size"
Displacement volume	see Chapter 2.1, "Basic type and nominal size"

3.4 Characteristic lines

3.4.1 Basic pump

Delivery flow and power

The diagrams show delivery flow and drive power over pressure without a controller at 1450 min⁻¹.

V30D-045

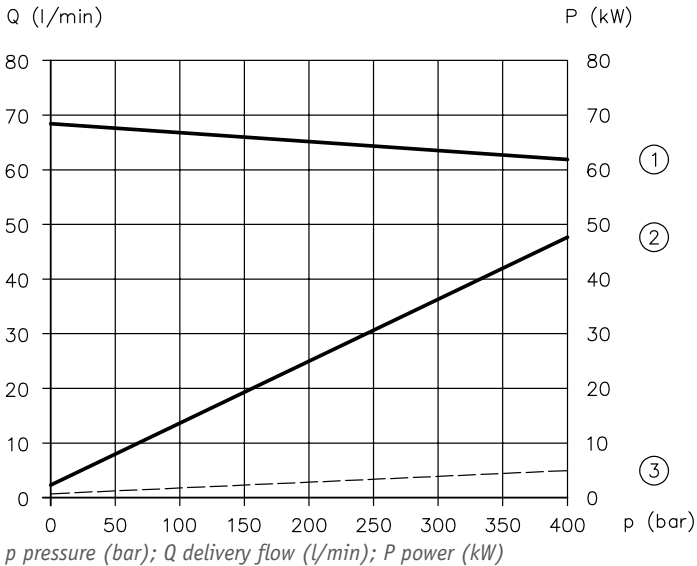

- 1 Delivery flow/pressure
- 2 Drive power/pressure (max. swash plate angle)
- 3 Drive power/pressure (zero stroke)

V30D-075

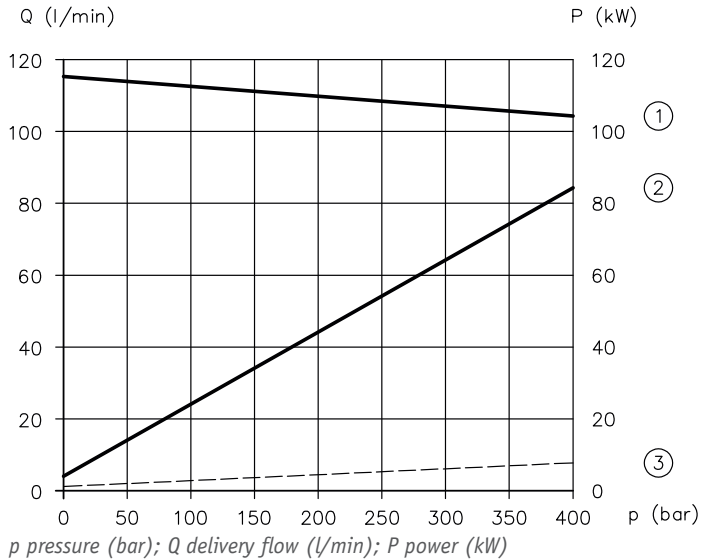

- 1 Delivery flow/pressure
- 2 Drive power/pressure (max. swash plate angle)
- 3 Drive power/pressure (zero stroke)

V30D-095(115)

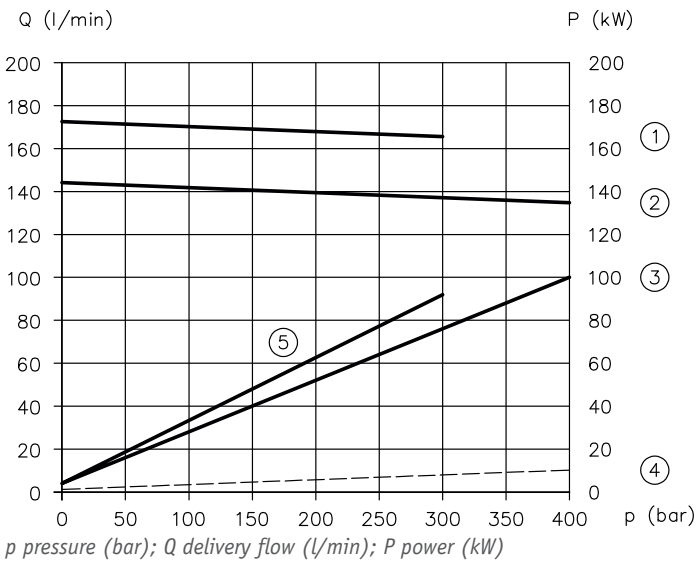

- 1 Delivery flow/pressure (V30D-115)
- 2 Delivery flow/pressure (V30D-095)
- 3 Drive power/pressure (V30D-095, max. swash plate angle)
- 4 Drive power/pressure (V30D-095/115, zero stroke)
- 5 Drive power/pressure (V30D-115, max. swash plate angle)

V30D-140(160)

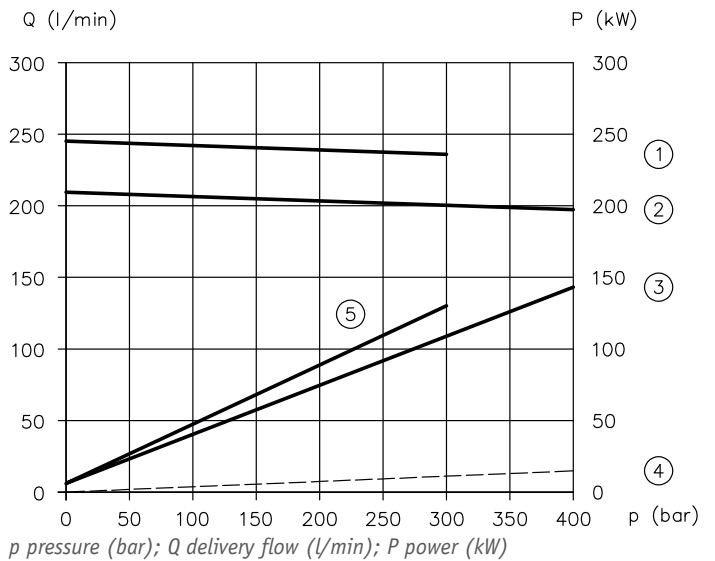

- 1 Delivery flow/pressure (V30D-160)
- 2 Delivery flow/pressure (V30D-140)
- 3 Drive power/pressure (V30D-140, max. swash plate angle)
- 4 Drive power/pressure (V30D-140/160, zero stroke)
- 5 Drive power/pressure (V30D-160, max. swash plate angle)

V30D-250

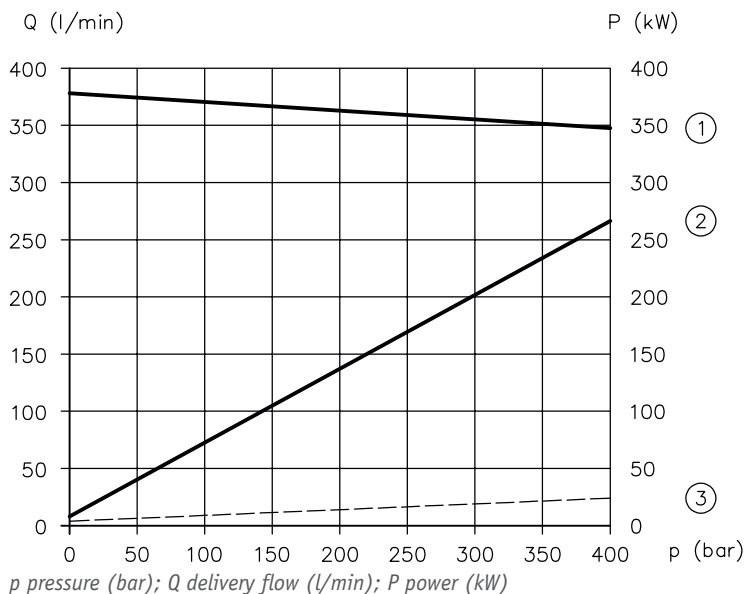

- 1 Delivery flow/pressure
- 2 Drive power/pressure (max. swash plate angle)
- 3 Drive power/pressure (zero stroke)

Inlet pressure and self-suction speed

The diagrams show the inlet pressure/rotation speed at the max. swash plate angle with an oil viscosity of 75 mm²/s.

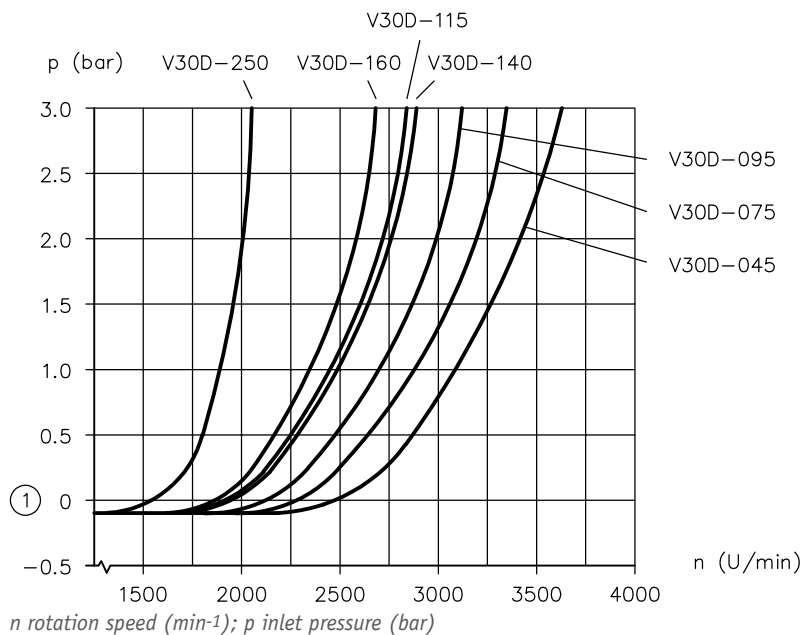

- 1 0 bar relative = 1 bar absolute

Acting times

Acting times T1 (LSN controller)

The diagram illustrates the on-stroke time based on the pressure for the LSN controller, i.e. the time required to swing out the pump and to adjust the geometric displacement from the minimum to the maximum.

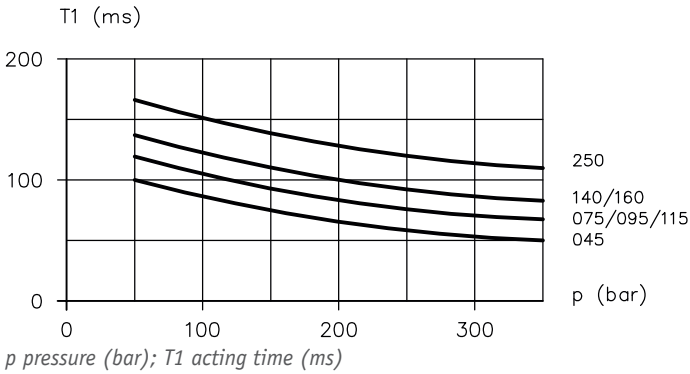

Acting times T2 (LSN controller)

The diagram illustrates the on-stroke time based on the pressure for the LSN controller, i.e. the time required to swing in the pump and to adjust the geometric displacement from the maximum to the minimum.

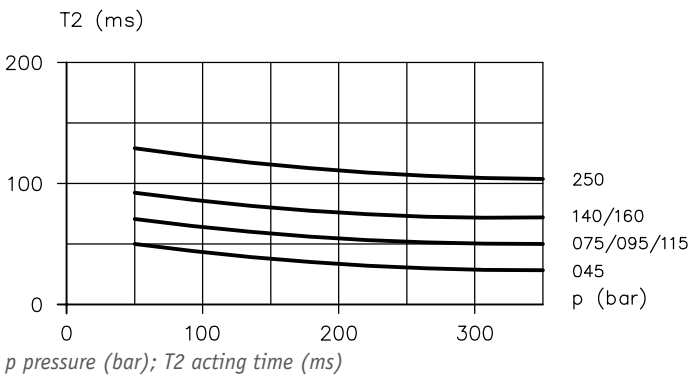

Acting times Tu, T1 and T2

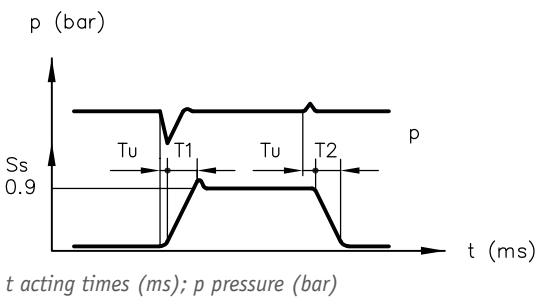

Ss Positioning travel of actuator

Tu Delay < 3 ms

T1 On-stroke time

T2 Destroke time

p Pressure

LS line approx. 10% of the volume of the P line

3.4.2 Swivel angle pick-up

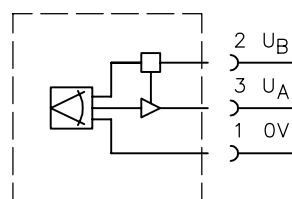
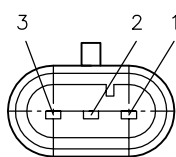
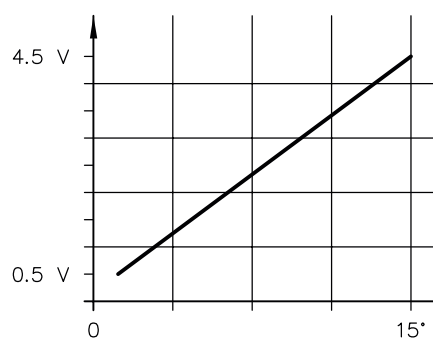

Operating voltage	U _B 10 ... 30 V DC
Output signal	U _A 0.5 ... 4.5 V
Tested for automotive field	DIN 40839
Test pulse	1, 2, 3 a/b
Electrical connection	3-PIN AMP Superseal 1.5 plug

3.5 Electrical data

Controller coding V

Nominal voltage	12 V DC	24 V DC
Resistance R ₂₀	4.6 Ω	21.7 Ω
Current, cold I ₂₀	2.6 A	1.2 A
Limit current I _G	1.8 A	0.81 A
Limit power P _G	21.5 W	21.5 W
Duty cycle	S1 (100%)	S1 (100%)
Dither frequency	50 - 150 Hz	50 - 150 Hz
Dither amplitude $A_D(\%) = \frac{I_{Peak-peak}}{I_G} \cdot 100$	20% ≤ A _D ≤ 40%	20% ≤ A _D ≤ 40%

Electrical connection

Coding V

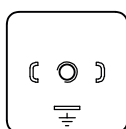
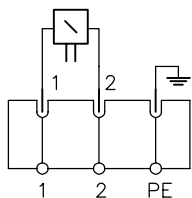

4 Dimensions

All dimensions in mm, subject to change.

4.1 Basic pump

4.1.1 V30D-045

Rotation direction **clockwise** (view: shaft journal)

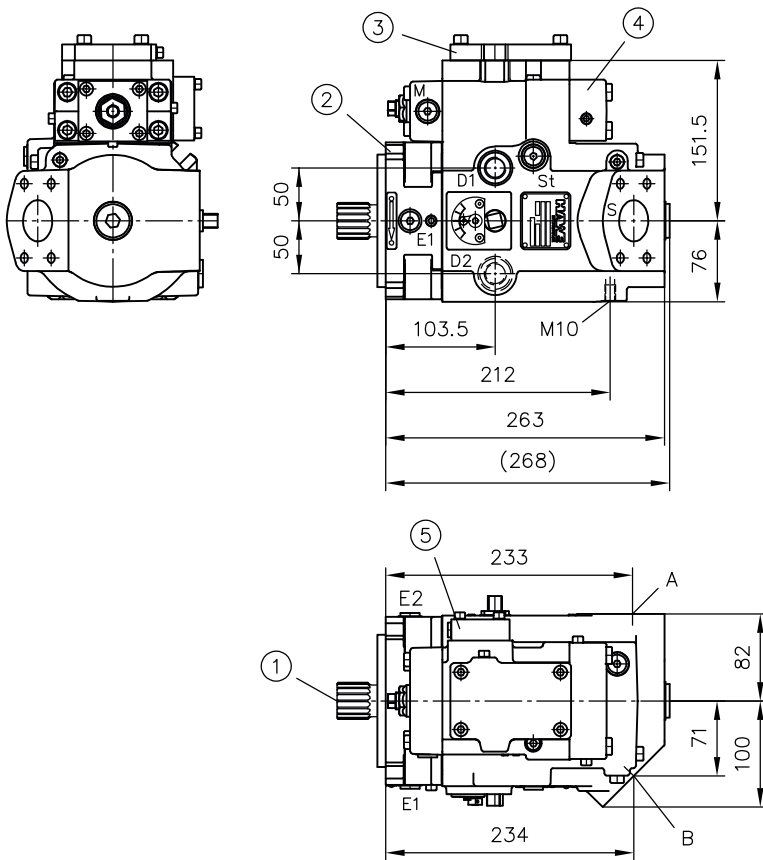

Rotation direction **anti-clockwise** (view: shaft journal)

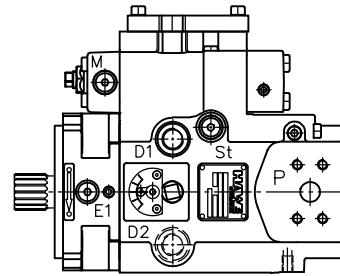

- 1 Shaft journal
- 2 Flange version
- 3 Controller for L, Lf1, LSD, PD5
- 4 Controller V, VH
- 5 Controller N, P, Pb, LS, Q, Qb, LSN, LSP

Pressure connection

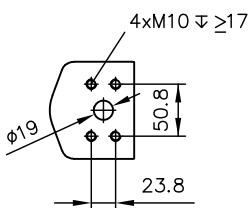

Suction port

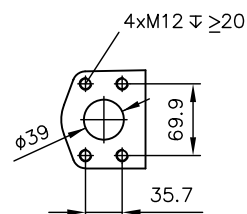

Ports (ISO 228-1)

D1, D2	Drain port G 3/4
E1	Venting and flushing port G 1/4 (9/16"-18 UNF for flange version "F")
E2	Venting and flushing port G 1/4 (flange version "F" only)
M	Measurement fitting G 1/4
St	Control oil connection G 1/4

Shaft journal
Spline shaft

Coding **D**
(W35x2x16x9g DIN 5480)

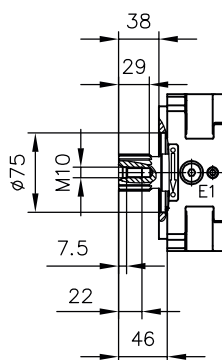

Coding **S**
(SAE-C J744 14T 12/24 DP)

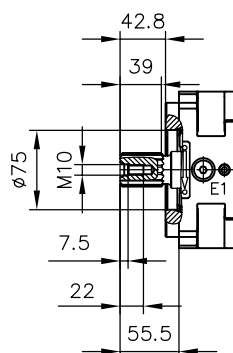
Parallel key shaft

Coding **K**
(Ø35 - AS10x8x56 DIN 6885)

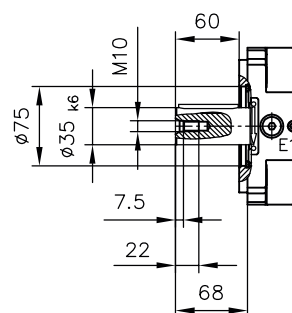
Flange versions

Coding **G**
(125 B4 HW DIN ISO 3019-2)

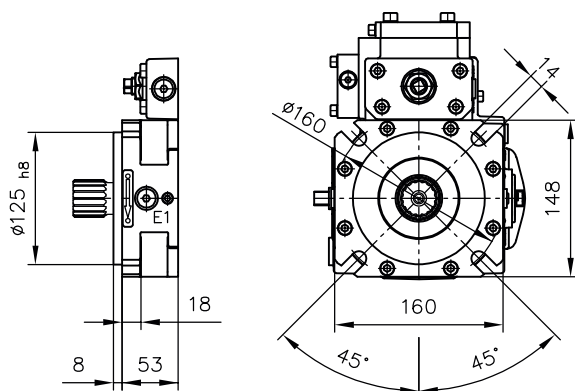

Coding **F**
(SAE-C 4-hole J744)
(127-4 DIN ISO 3019-1)

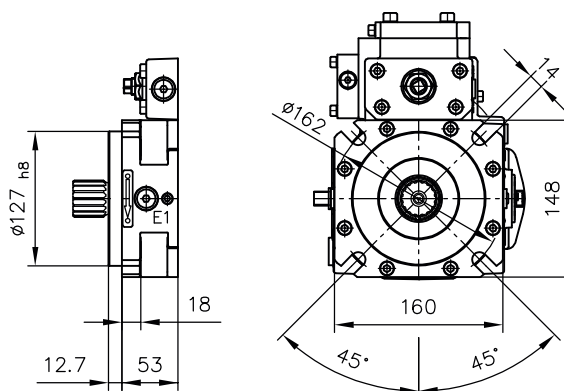

Housing version -2 (with thru-shaft)

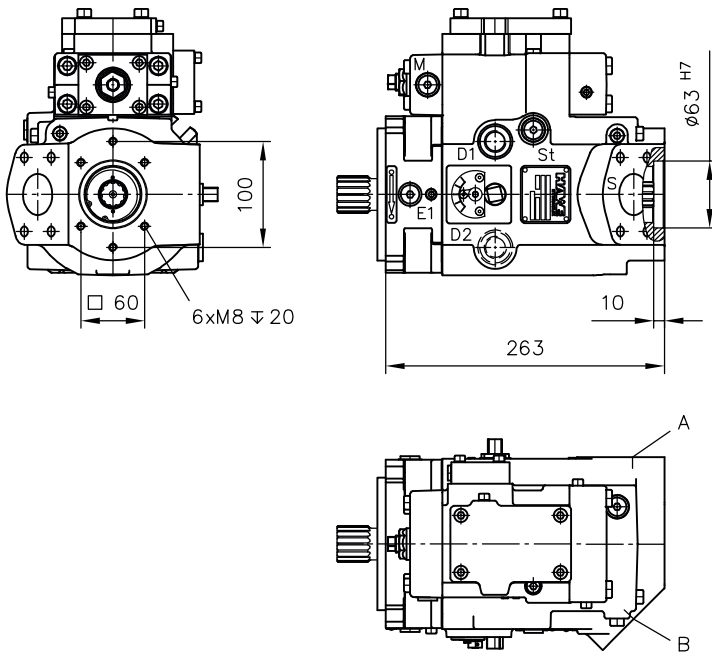

Flange version (output side)

Coding **C411, C412, C413**
(SAE-A 2-hole)

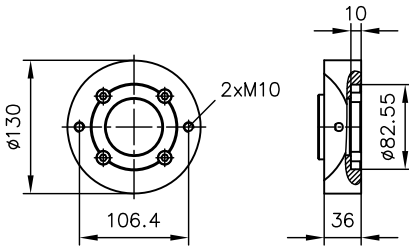

Coding **C414 and C416**
(SAE-B 2-hole)

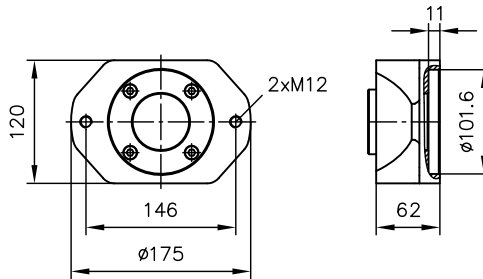

Coding **C415**
(SAE-B 4-hole)

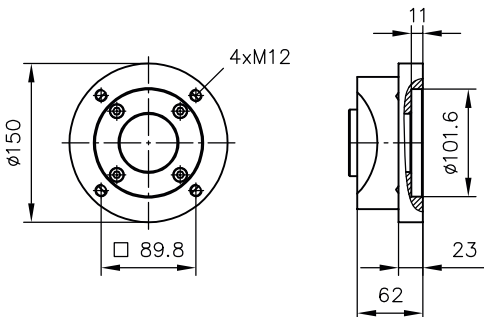

Coding **C418**
(SAE-C 4-hole)

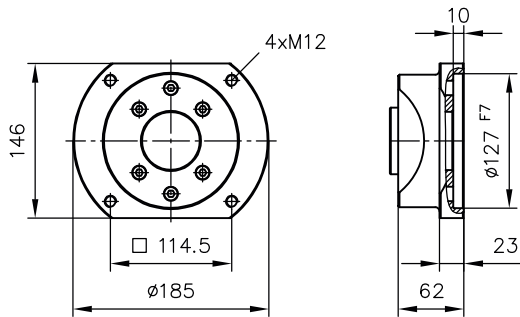

4.1.2 V30D-075

Rotation direction **clockwise** (viewed from shaft journal)

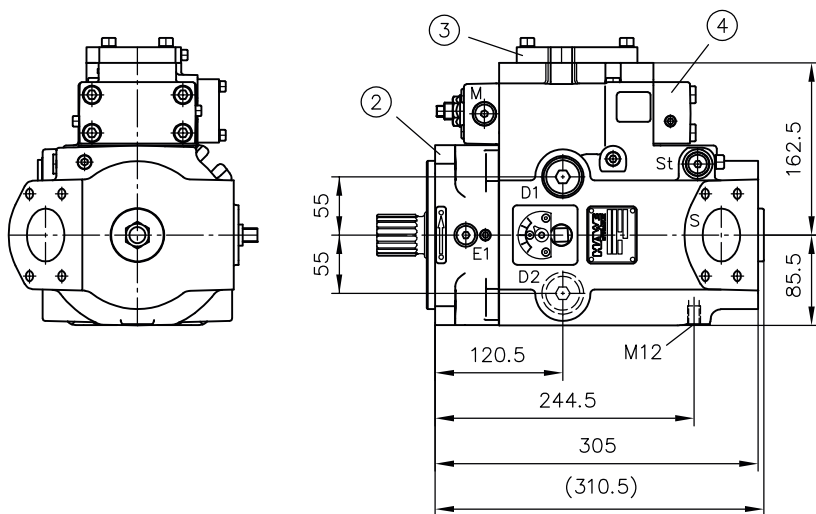

Rotation direction **anti-clockwise** (viewed from shaft journal)

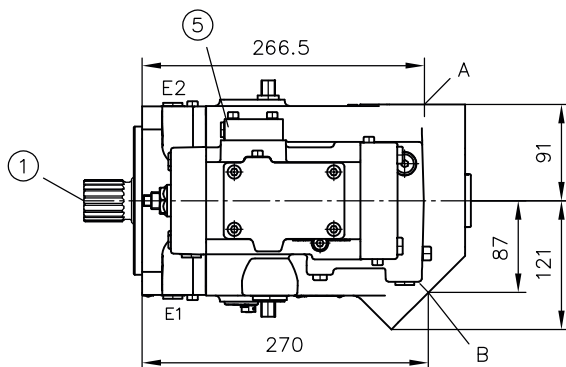
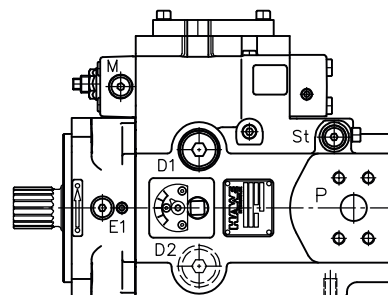

- 1 Shaft journal
- 2 Flange version
- 3 Controller for L, Lf1, LSD, PD5
- 4 Controller V, VH
- 5 Controller N, P, Pb, LS, Q, Qb, LSN, LSP

Pressure connection

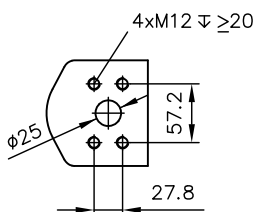

Suction port

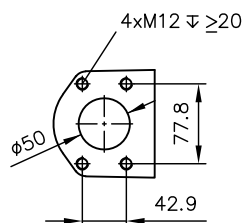

Ports (ISO 228-1)

D1, D2	Drain port G 3/4
E1	Venting and flushing port G 1/4 (9/16"-18 UNF for flange version "F")
E2	Venting and flushing port G 1/4 (flange version "F" only)
M	Measurement fitting G 1/4
St	Control oil connection G 1/4

Housing version -2 (with thru-shaft)

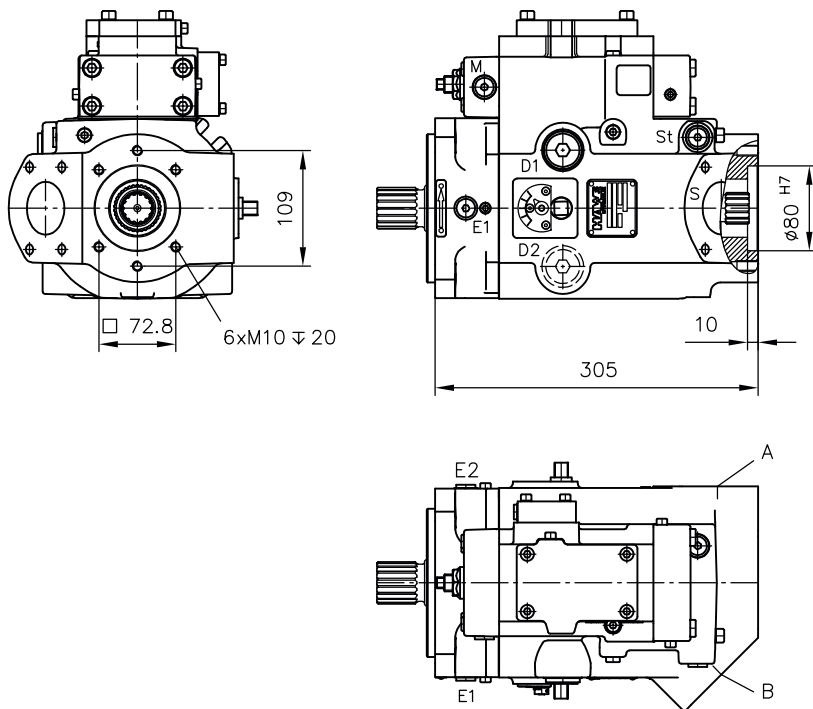

Flange version (output side)

Coding **C421, C422, C423**
(SAE-A 2-hole)

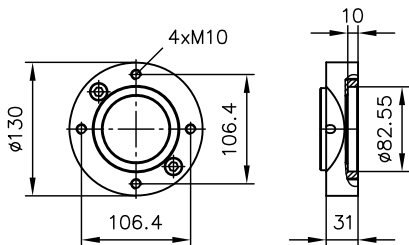

Coding **C424 and C426**
(SAE-B 2-hole)

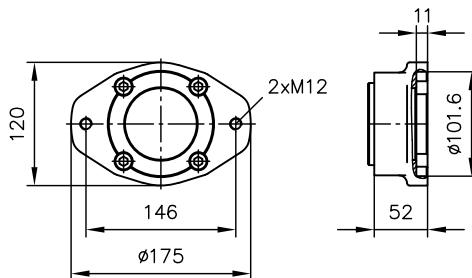

Coding **C425**
(SAE-B 4-hole)

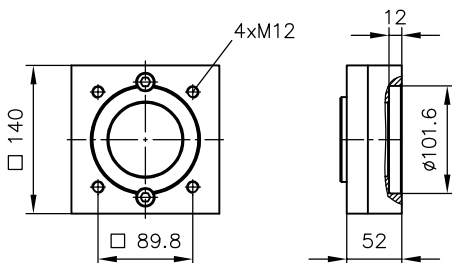

Coding **C427 and C429**
(SAE-C 2-hole)

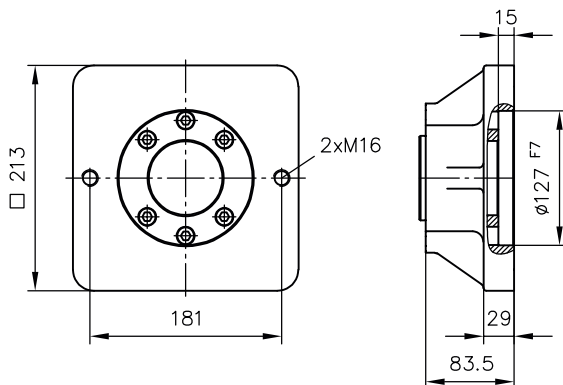

Coding **C428**
(SAE-C 4-hole)

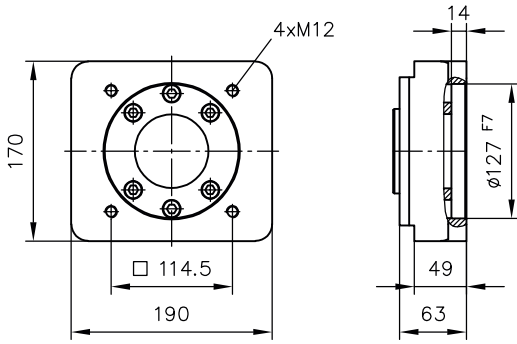

4.1.3 V30D-095/115

Rotation direction **clockwise** (viewed from shaft journal)

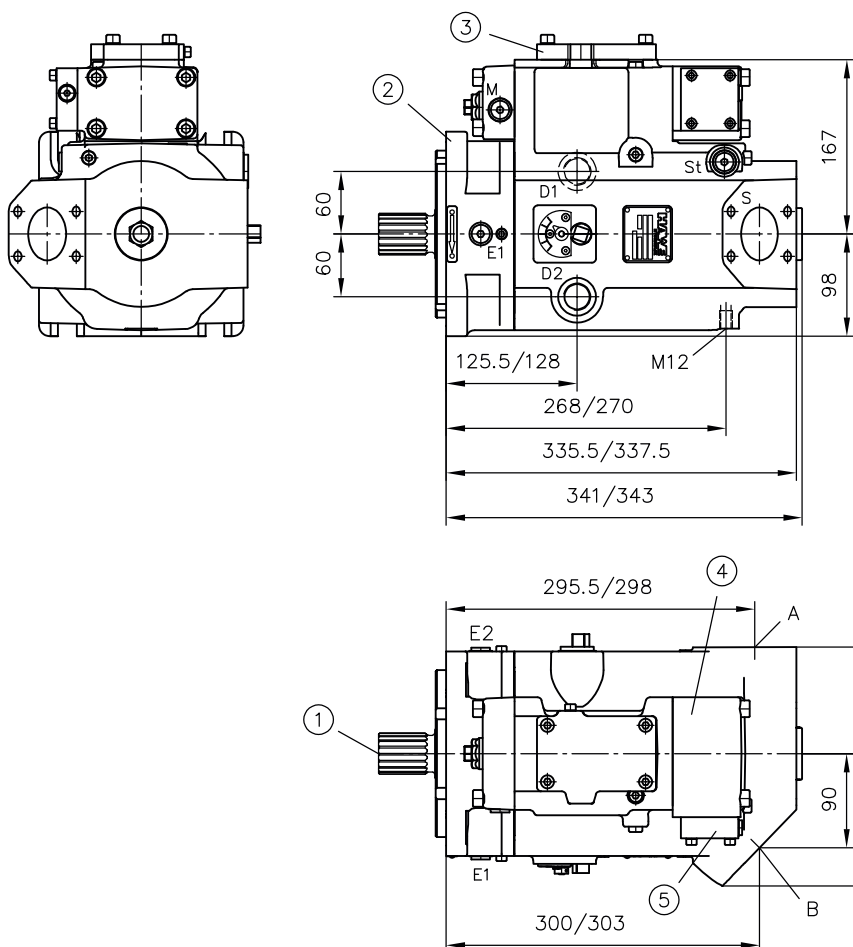

Rotation direction **anti-clockwise** (viewed from shaft journal)

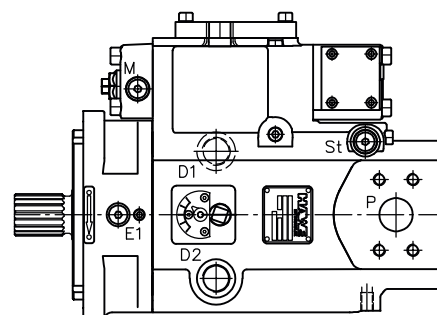

- 1 Shaft journal
- 2 Flange version
- 3 Controller for L, Lf1, LSD, PD5
- 4 Controller V, VH
- 5 Controller N, P, Pb, LS, Q, Qb, LSN, LSP

Pressure connection

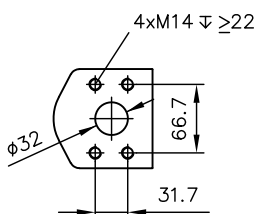

Suction port

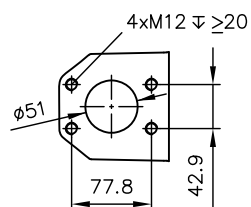

Ports (ISO 228-1)

D1, D2	Drain port G 3/4
E1	Venting and flushing port G 1/4 (9/16"-18 UNF for flange version "F")
E2	Venting and flushing port G 1/4 (flange version "F" only)

Ports (ISO 228-1)

M	Measurement fitting G 1/4
St	Control oil connection G 1/4

Shaft journal

Spline shaft

Coding **D**
(W40x2x18x9g DIN 5480)

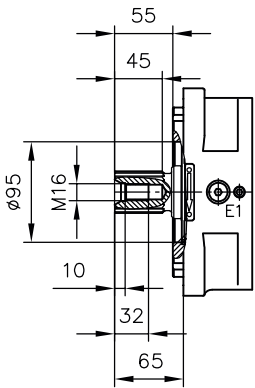

Coding **S**
(SAE-D J744 13T 8/16 DP)

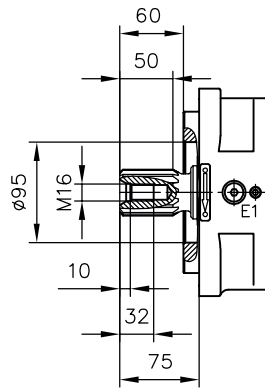

Parallel key

Coding **K**
($\varnothing 40$ - A12x8x80 DIN 6885)

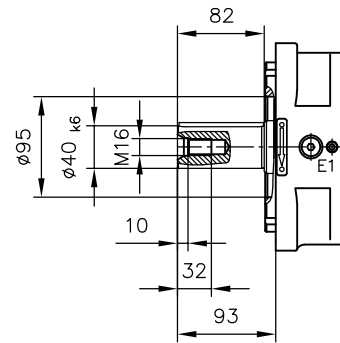

Flange versions

Coding **G**
(160 B4 HW DIN ISO 3019-2)

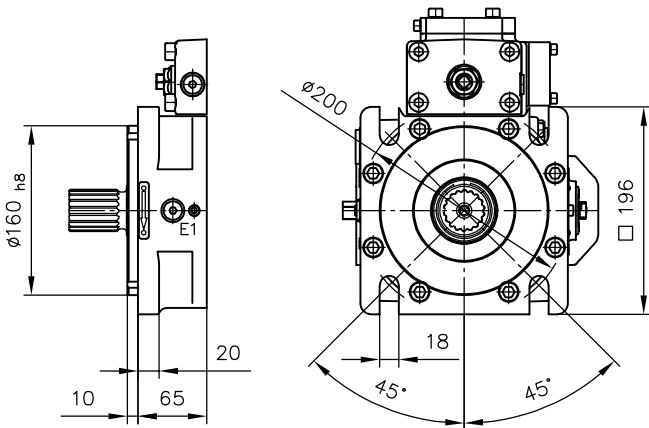

Coding **F**
(SAE-D 4-hole J744)
(152-4 DIN ISO 3019-1)

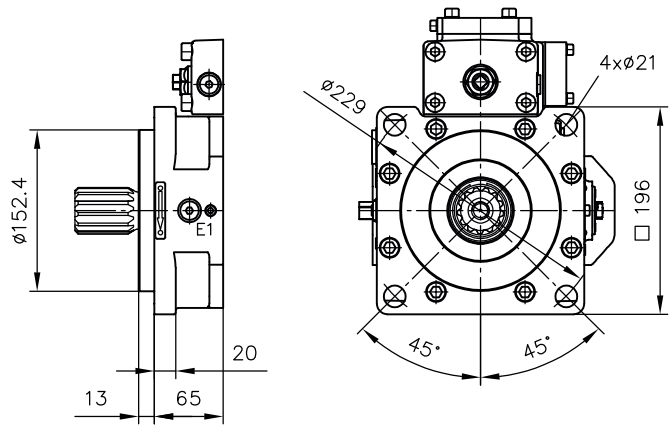

Housing version -2 (with thru-shaft)

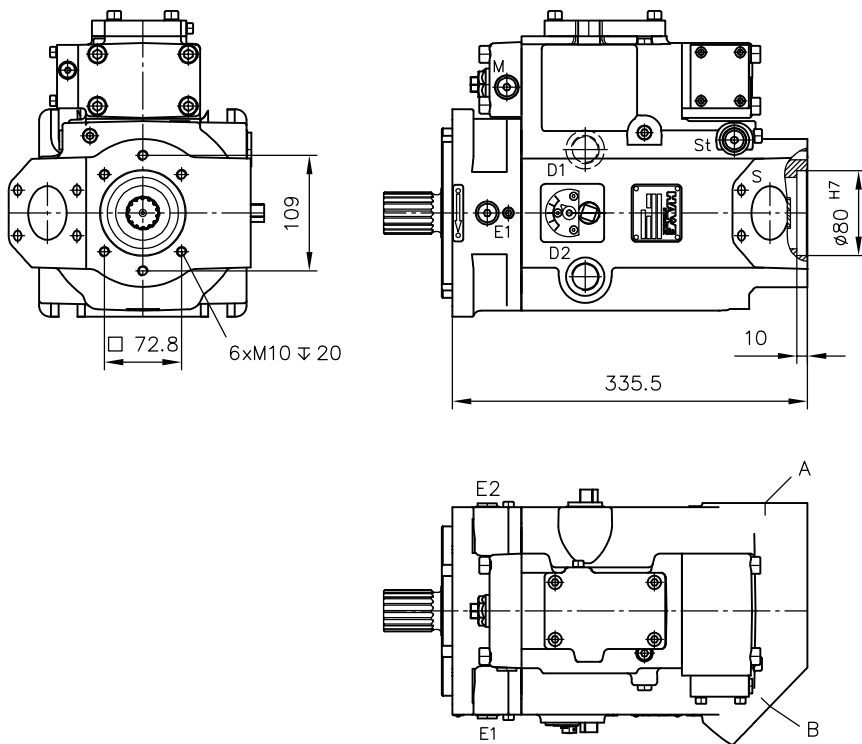

Flange version (output side)

Coding **C431 (C441), C432 (C442), C433 (C443)**
(SAE-A 2-hole)

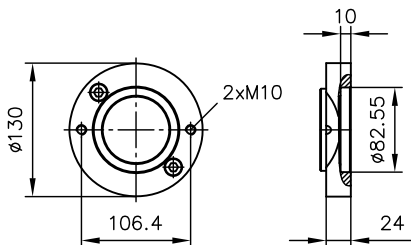

Coding **C434 (C444), C436 (C446)**
(SAE-B 2-hole)

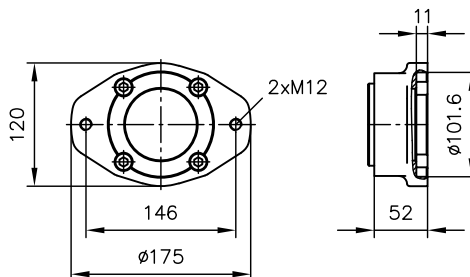

Coding **C435 (C445)**
(SAE-B 4-hole)

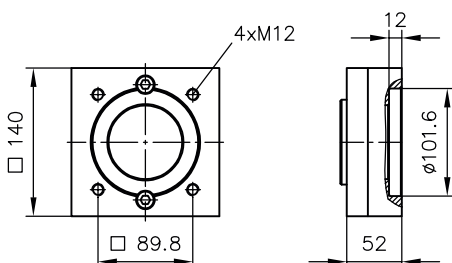

Coding **C437 (C447), C439 (C449)**
(SAE-C 2-hole)

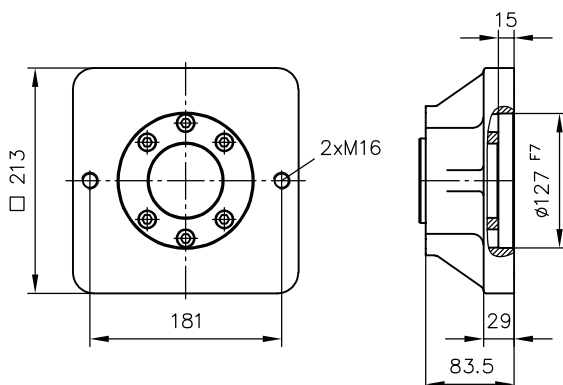

Coding **C438 (C448)**
(SAE-C 4-hole)

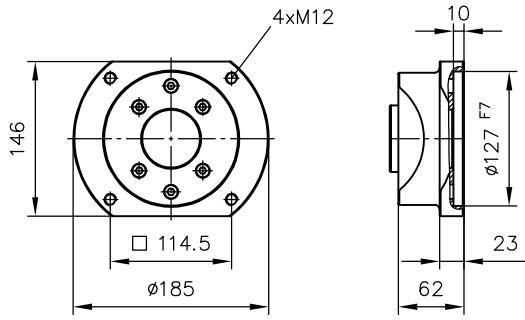

Coding **C440 (C450)**
(SAE-D 4-hole)

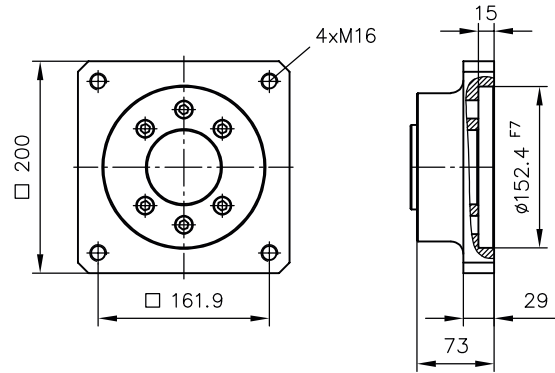

4.1.4 V30D-140/160

Rotation direction **clockwise** (viewed from shaft journal)

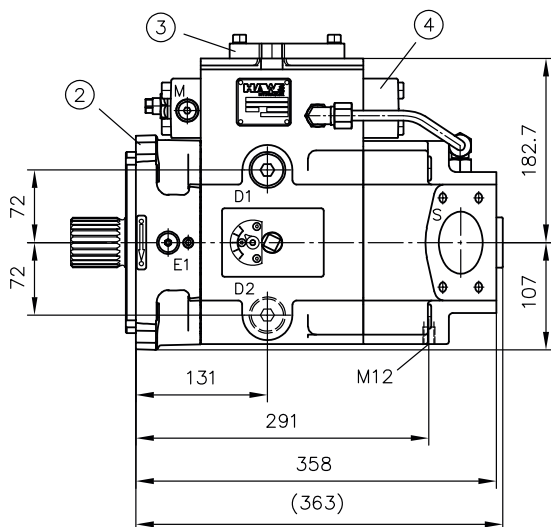
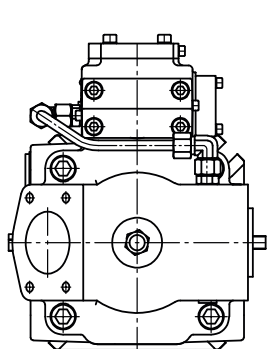

Rotation direction **anti-clockwise** (viewed from shaft journal)

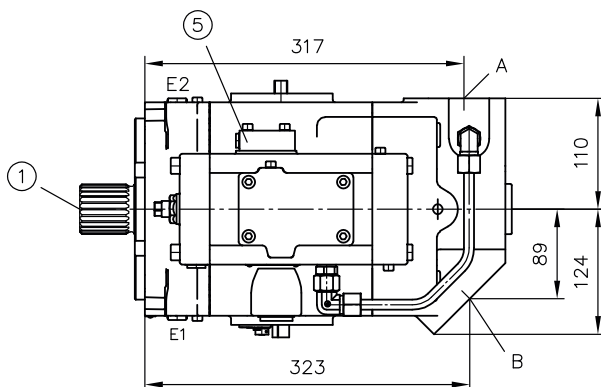
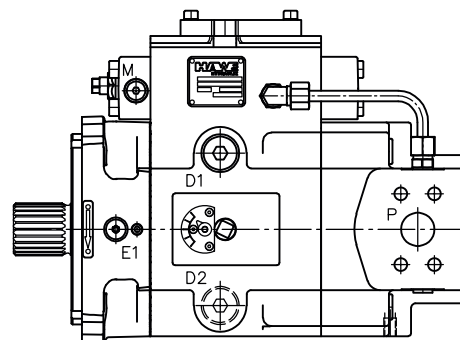

- 1 Shaft journal
- 2 Flange version
- 3 Controller for L, Lf1, LSD, PD5
- 4 Controller V, VH
- 5 Controller N, P, Pb, LS, Q, Qb, LSN, LSP

Pressure connection

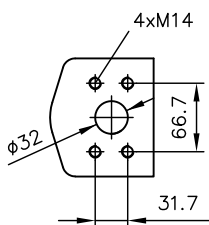

Suction port

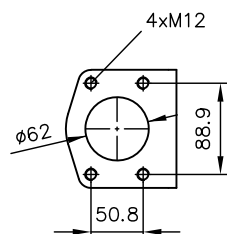

Ports (ISO 228-1)

D1, D2	Drain port G 3/4
E1	Venting and flushing port G 1/4 (9/16"-18 UNF for flange version "F")
E2	Venting and flushing port G 1/4 (flange version "F" only)

Ports (ISO 228-1)

M	Measurement fitting G 1/4
St	Control oil connection G 1/4

Shaft journal

Spline shaft

Coding D
(W50x2x24x9g DIN 5480)

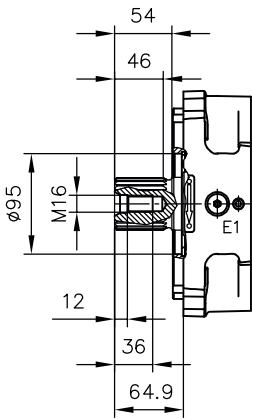

Coding S
(SAE-D J744 13T 8/16 DP)

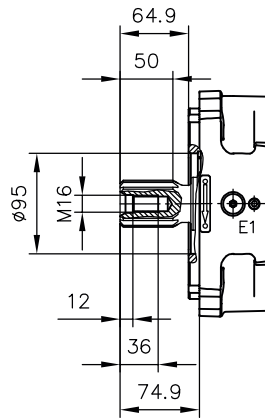

Parallel key

Coding K
($\varnothing 50$ - AS14x9x80 DIN 6885)

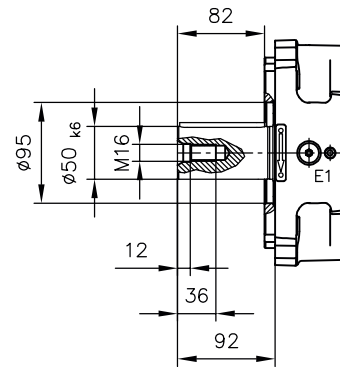

Flange versions

Coding G
(180 B4 HW DIN ISO 3019-2)

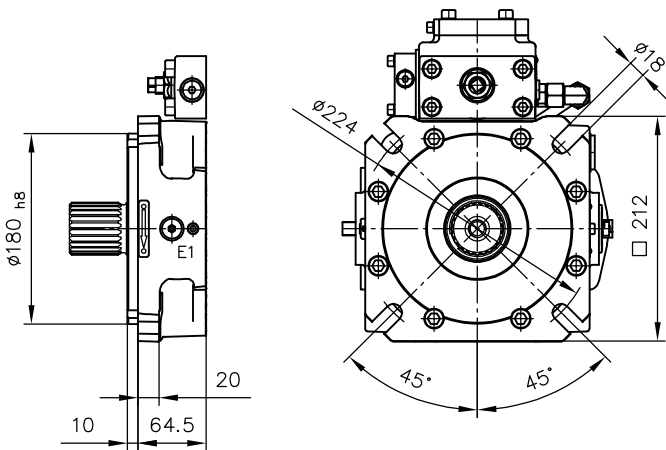

Coding F
(SAE-D 4-hole J744)
(152-4 DIN ISO 3019-1)

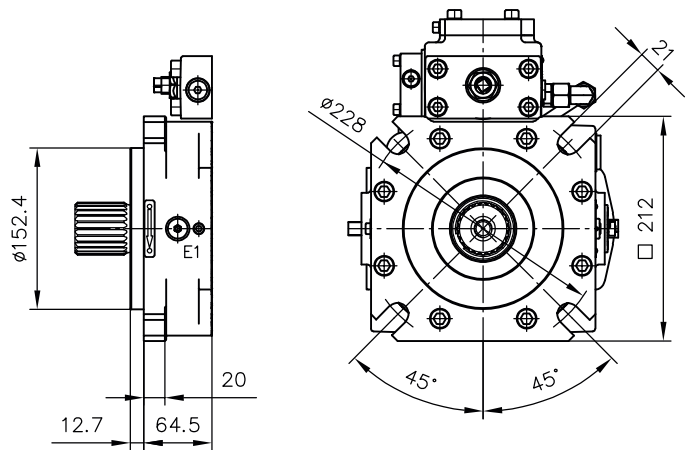

Housing version -2 (with thru-shaft)

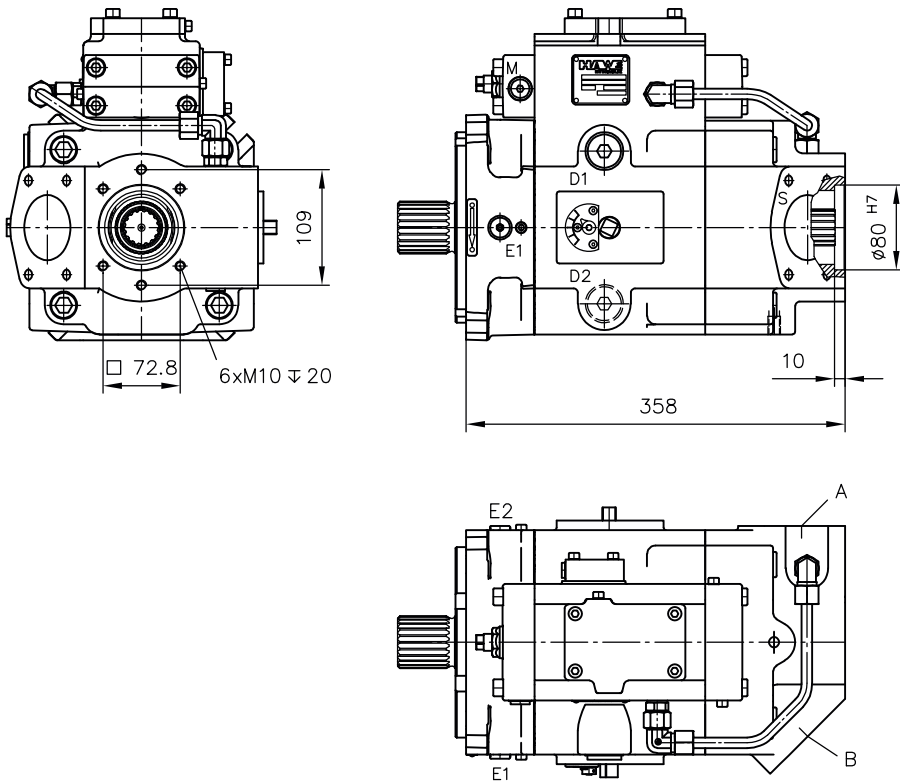

Flange version (output side)

Coding **C451 (C461), C452 (C462), C453 (C463)**
(SAE-A 2-hole)

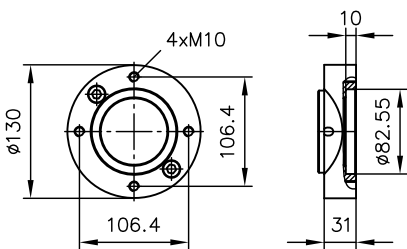

Coding **C454 (C464), C456 (C466)**
(SAE-B 2-hole)

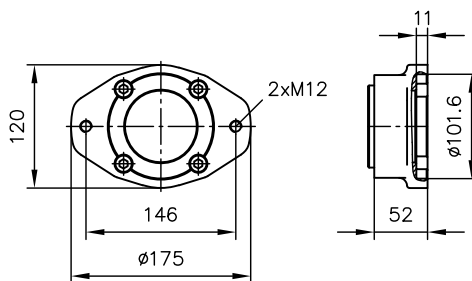

Coding **C455 (C465)**
(SAE-B 4-hole)

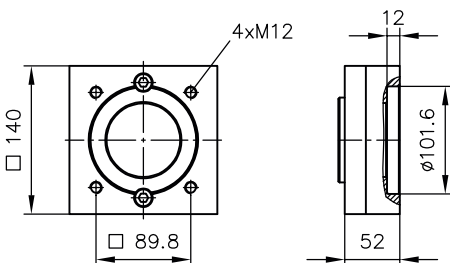

Coding **C457 (C467), C459 (C469)**
(SAE-C 2-hole)

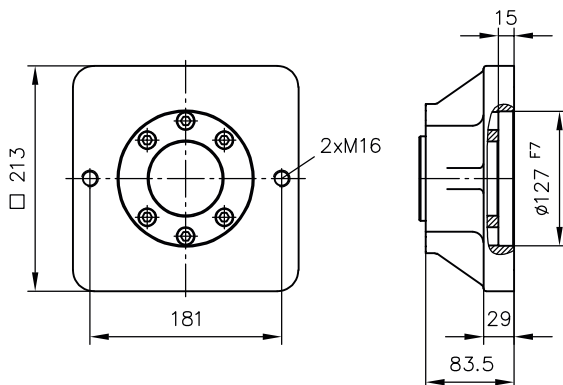

Coding **C458 (C468)**
(SAE-C 4-hole)

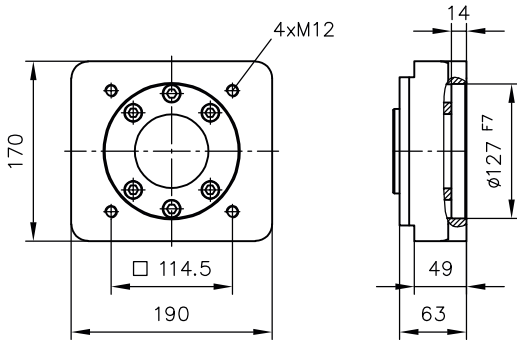

Coding **C460 (C470)**
(SAE-D 4-hole)

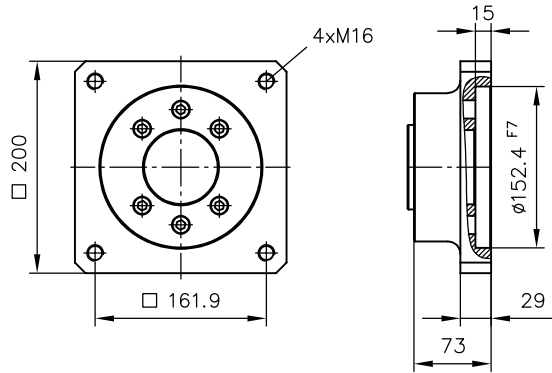

4.1.5 V30D-250

Rotation direction **clockwise** (viewed from shaft journal)

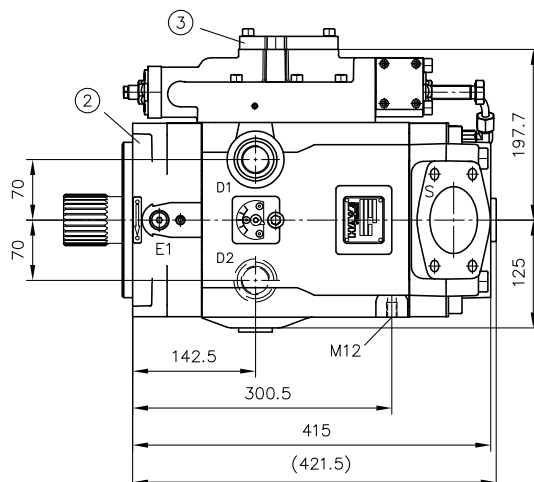
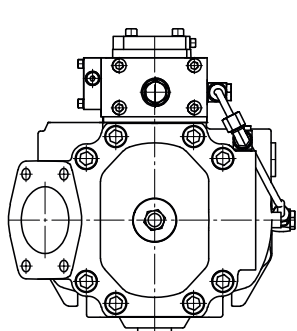

Rotation direction **anti-clockwise** (viewed from shaft journal)

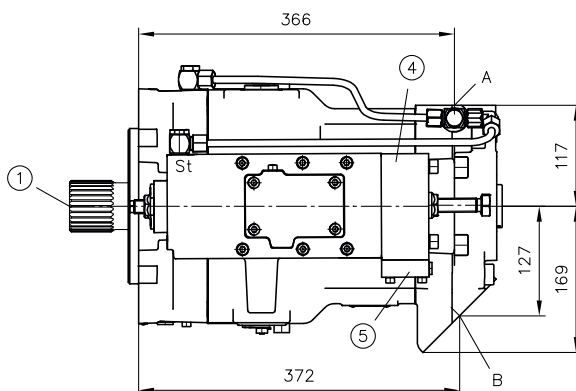
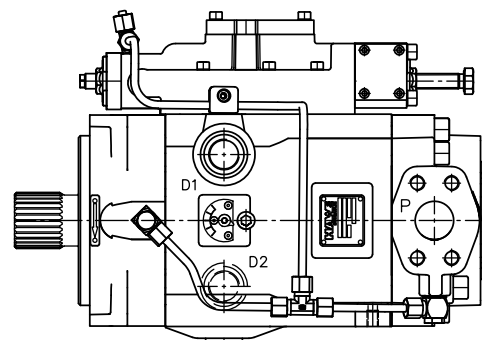

- 1 Shaft journal
- 2 Flange version
- 3 Controller for L, Lf1, LSD, PD5
- 4 Controller V, VH
- 5 Controller N, P, Pb, LS, Q, Qb, LSN, LSP

Pressure connection

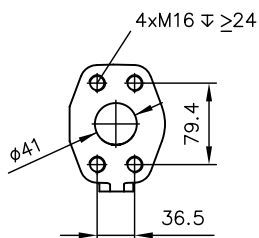

Suction port

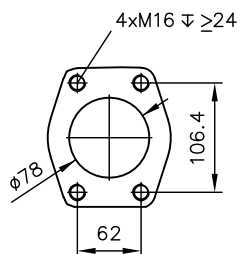

Ports (ISO 228-1)

D1, D2	Drain port M33x2
E1	Venting and flushing port G 1/4 (9/16"-18 UNF for flange version "F")
St	Control oil and pipe connection Ø8

Shaft journal

Spline shaft

Coding **D**
(W60x2x28x9g DIN 5480)

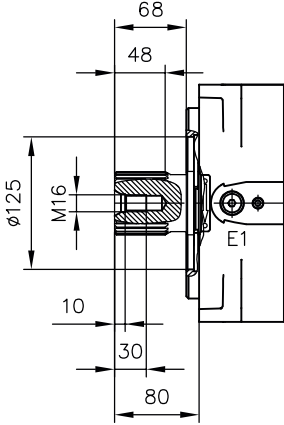

Coding **U**
(SAE-D J744 13T 8/16 DP)

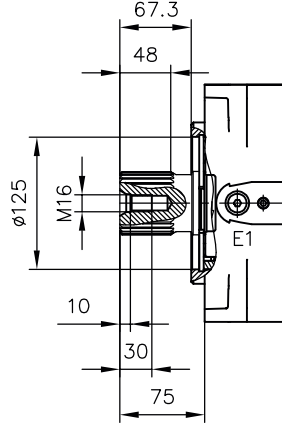

Parallel key

Coding **K**
(Ø60 - AS18x11x100 DIN 6885)

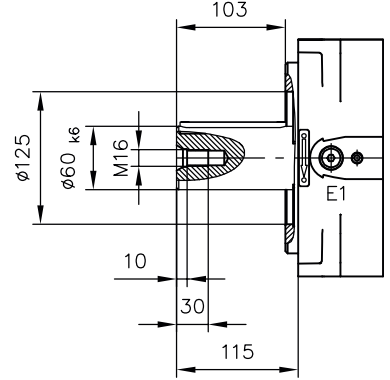

Flange versions

Coding **G**
(180 B4 HW DIN ISO 3019-2)

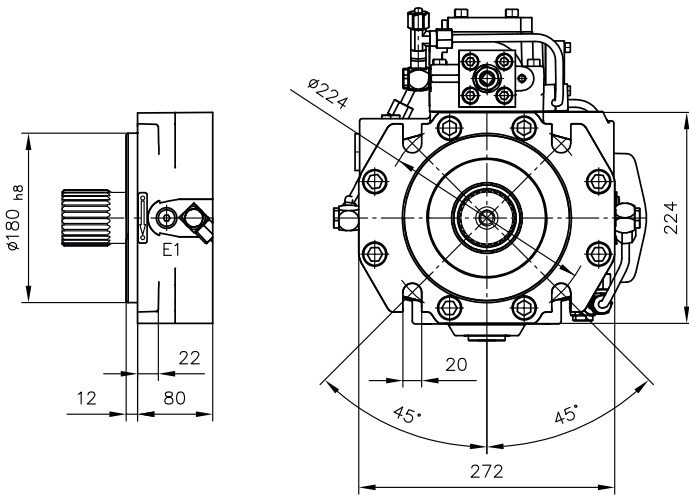

Coding **W**
(SAE-D 4-hole J744)
(152-4 DIN ISO 3019-1)

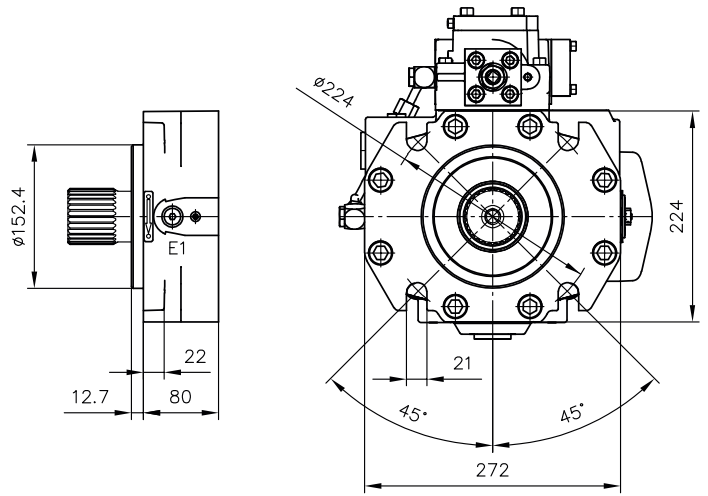

Housing version -2 (with thru-shaft)

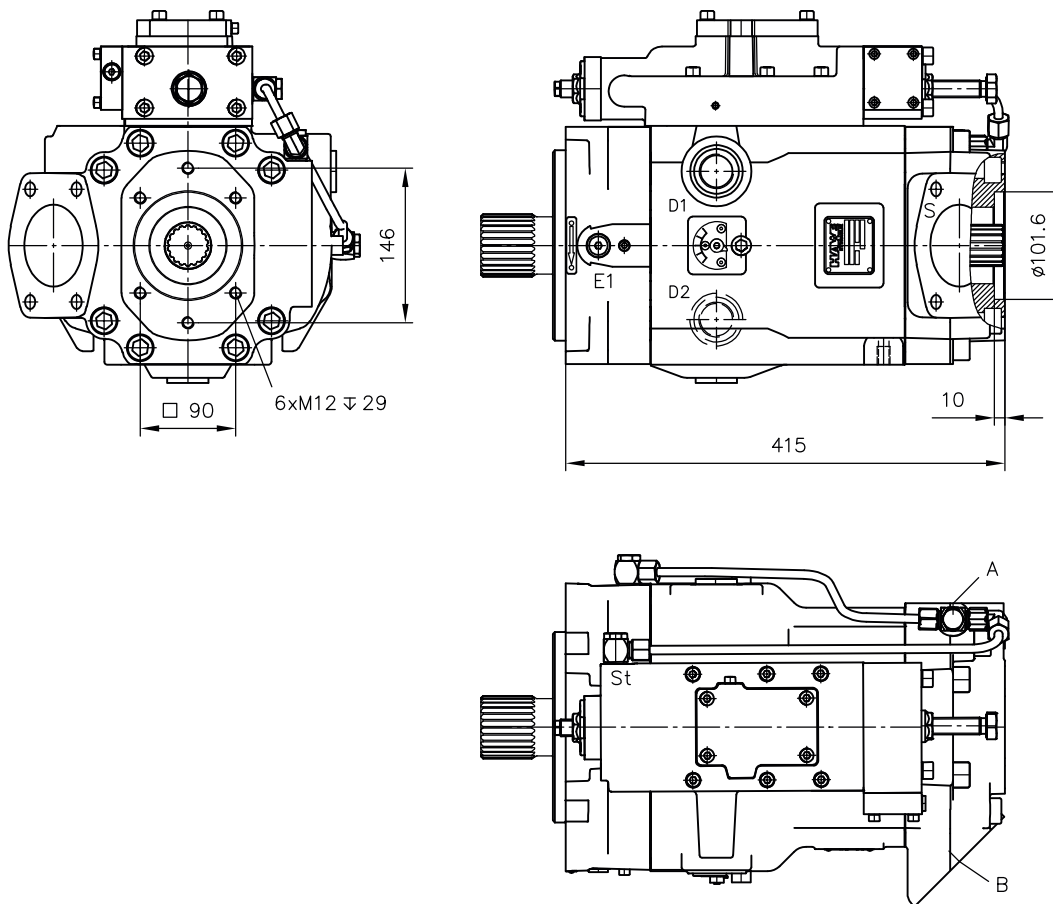

Flange version (output side)

Coding **C471, C472, C473**
(SAE-A 2-hole)

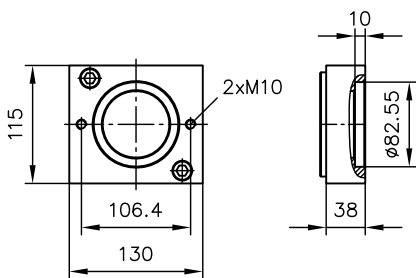

Coding **C474 and C476**
(SAE-B 2-hole)

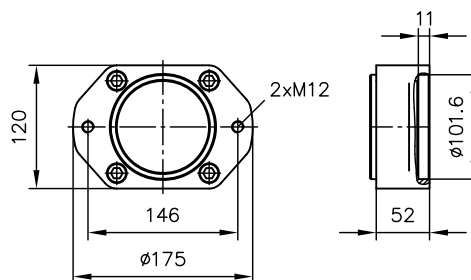

Coding **C475**
(SAE-B 4-hole)

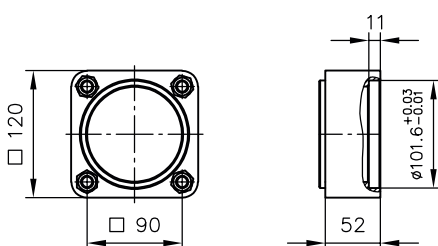

Coding **C477 and C479**
(SAE-C 2-hole)

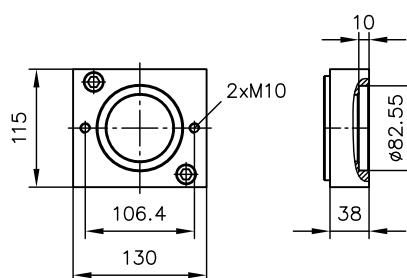

Coding **C478**
(SAE-C 4-hole)

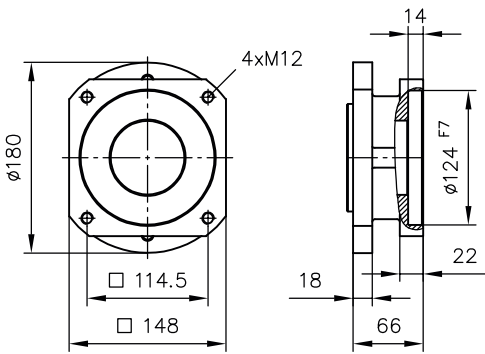

Coding **C480**
(SAE-D 4-hole)

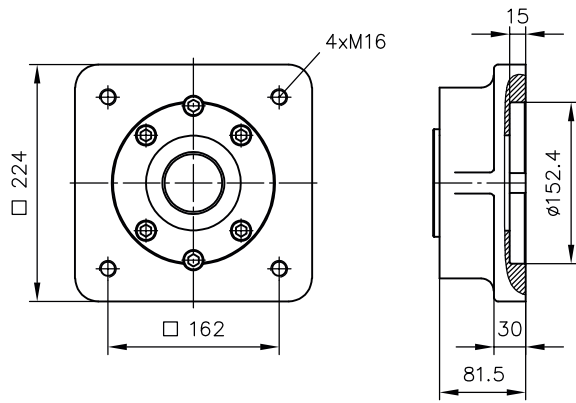

4.2 Swivel angle indicator

Swivel angle indicator

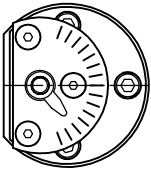

Swivel angle pick-up

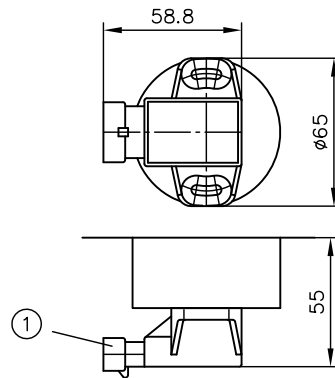

1 3-PIN AMP Superseal

4.3 Controllers

Coding LS

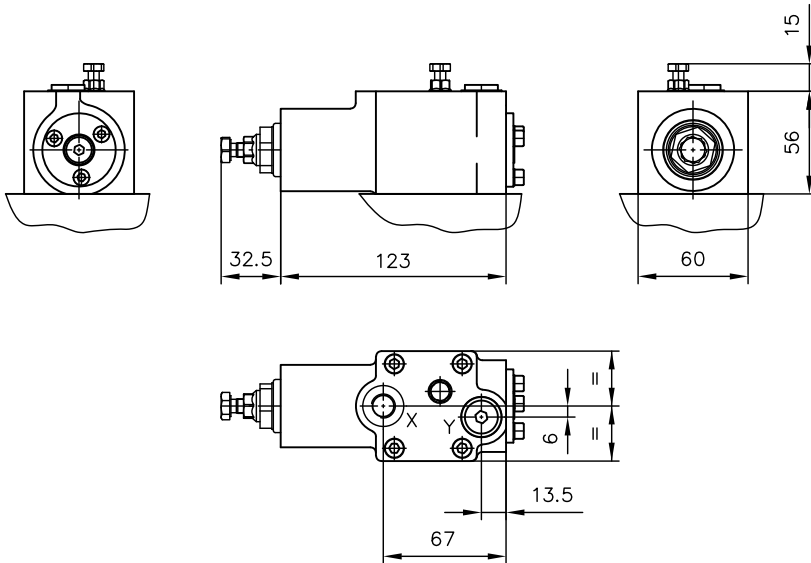

Coding LSN, LSP

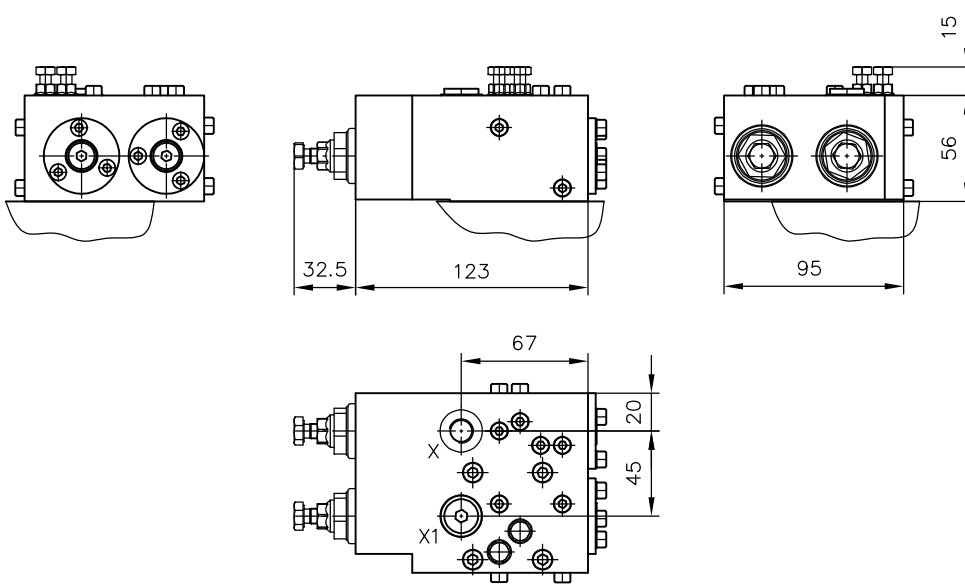

LSD

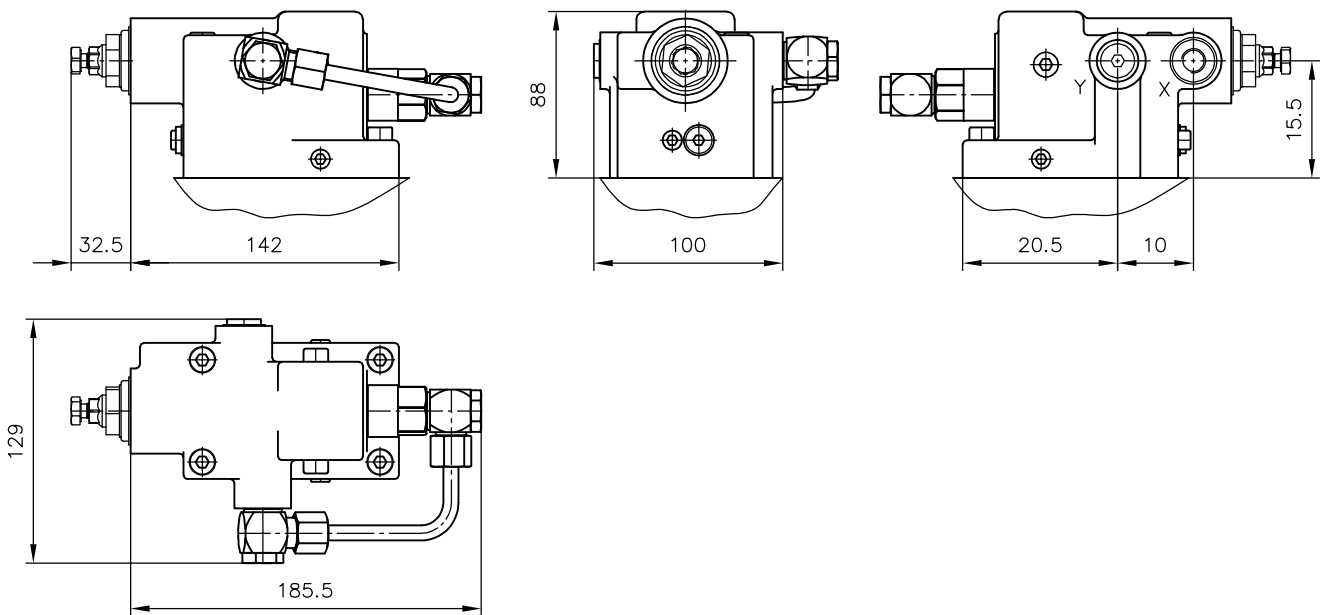

Coding **Q, Qb**

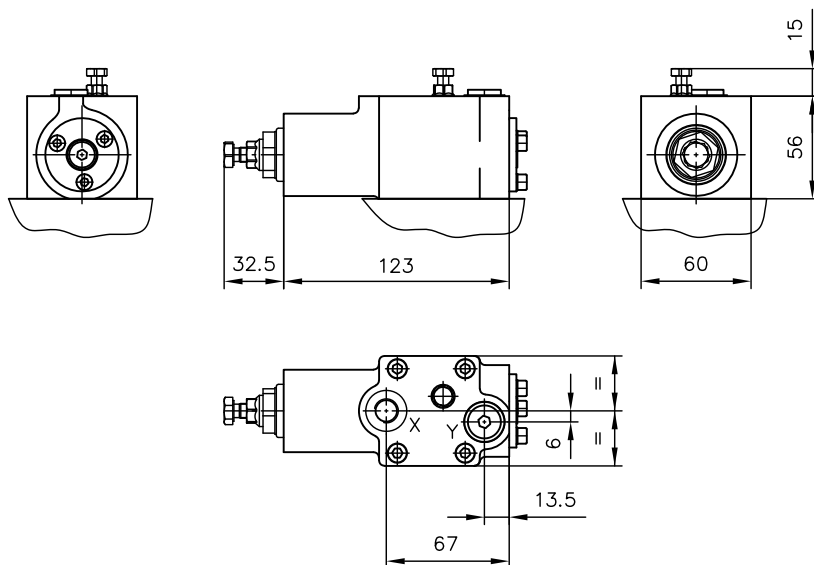

Coding **VH**

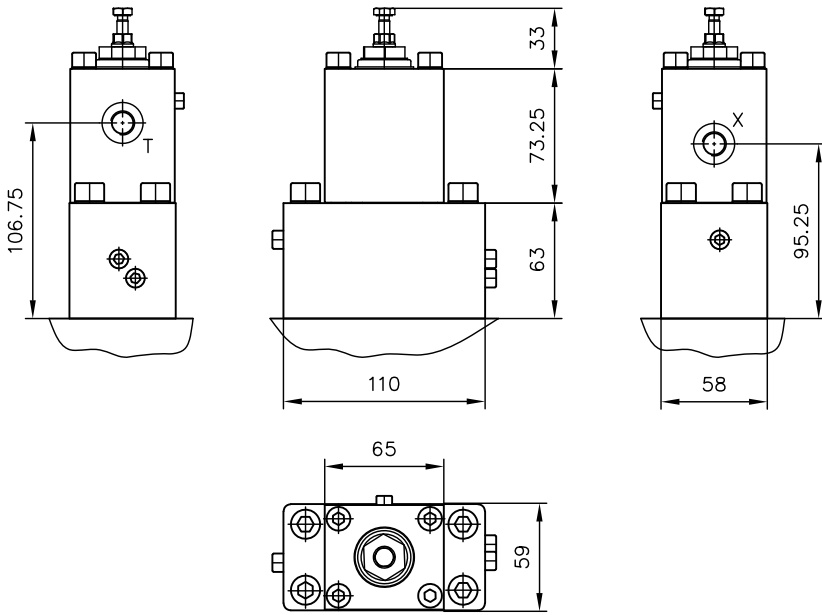

Coding **V**

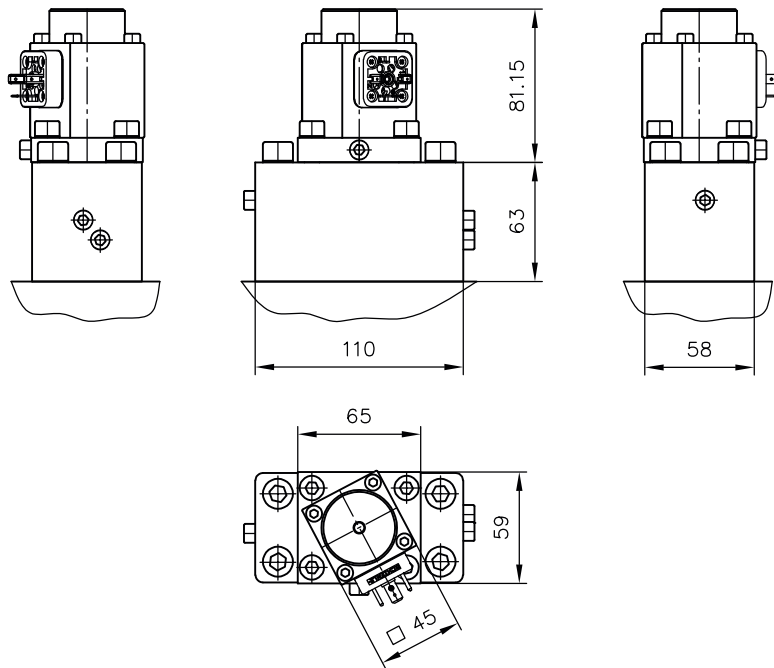

Coding **N, P, Pb**

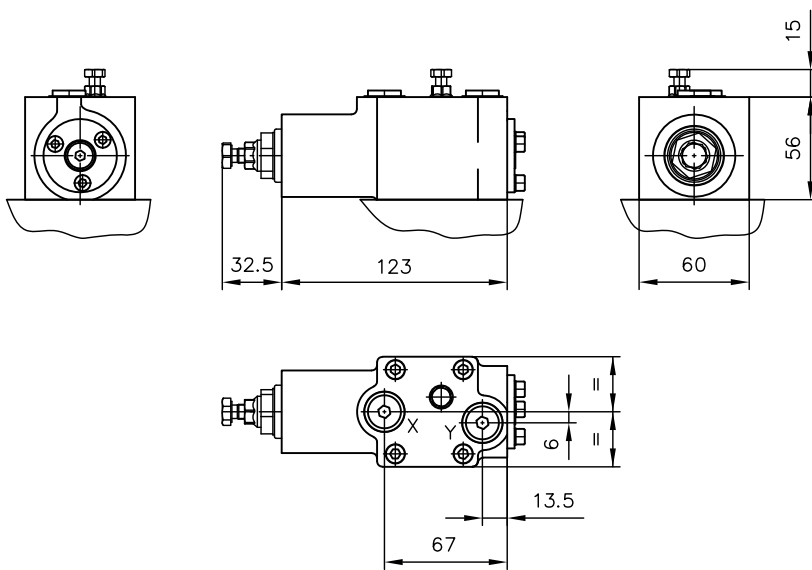

Coding **PD5**

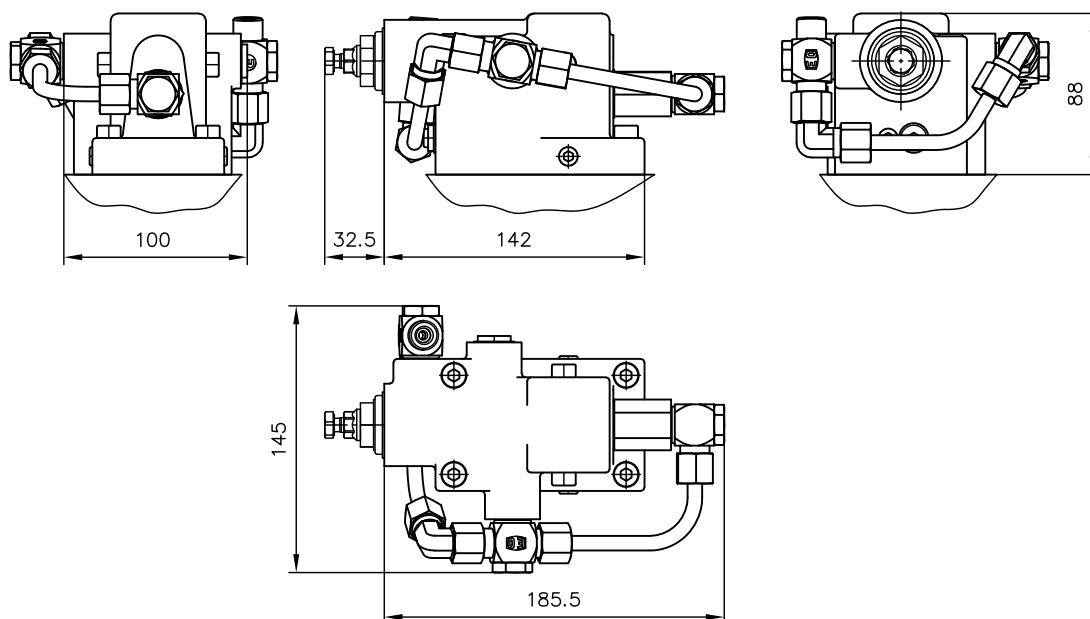

Coding L

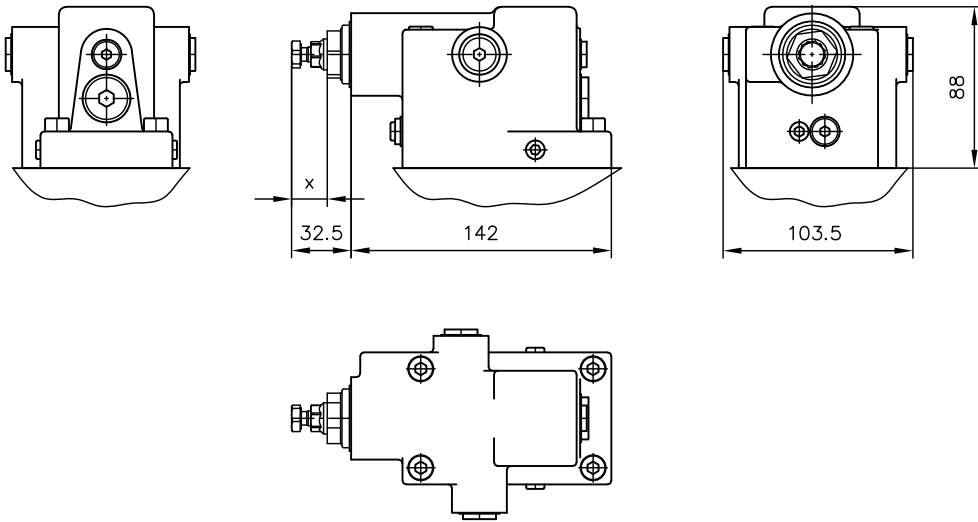

Coding Lf1

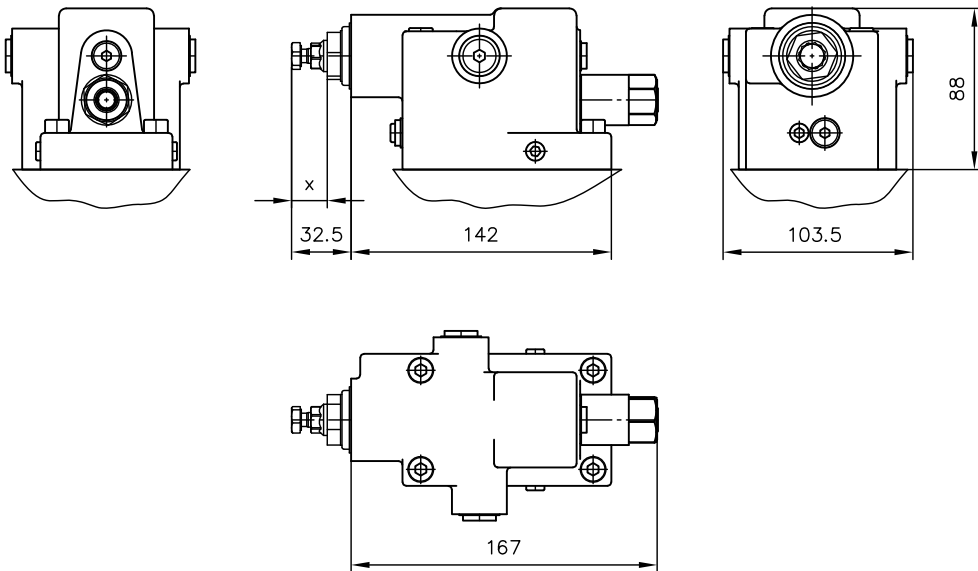

5 Installation, operation and maintenance information

Observe the document B 5488 "General operating instructions for assembly, commissioning, and maintenance."

5.1 Intended use

This product is intended exclusively for hydraulic applications (fluid technology).

The user must observe the safety measures and warnings in this document.

Essential requirements for the product to function correctly and safely:

- ▶ All information in this documentation must be observed. This applies in particular to all safety measures and warnings.
- ▶ The product must only be assembled and put into operation by specialist personnel.
- ▶ The product must only be operated within the specified technical parameters described in detail in this document.
- ▶ All components must be suitable for the operating conditions when using an assembly.
- ▶ The operating instructions for the components, assemblies and the specific complete system must also always be observed.

If the product can no longer be operated safely:

1. Remove the product from operation and mark it accordingly.
 - ✓ It is then not permitted to continue using or operating the product.

5.2 Assembly information

The product must only be installed in the complete system with standard and compliant connection components (screw fittings, hoses, pipes, fixtures etc.).

The product must be shut down correctly prior to disassembly (in particular in combination with hydraulic accumulators).



DANGER

Sudden movement of the hydraulic drives when disassembled incorrectly

Risk of serious injury or death

- ▶ Depressurise the hydraulic system.
- ▶ Perform safety measures in preparation for maintenance.

5.2.1 General information

The variable displacement axial piston pump V30D is designed for use in an open circuit. It can be mounted via a mounting flange according to DIN ISO 3019-1 or DIN ISO 3019-2 .

During assembly, note the following principles:

- Only trained persons are allowed to mount or remove the pump.
- Always ensure absolute cleanliness to prevent contamination from affecting the pump.
- Remove all plastic plugs before operation.
- Avoid installation above the tank (see Chapter 5.2.3, "Installation positions").
- Observe the electric reference values.
- Before initial use, fill the pump with hydraulic fluid and bleed. Automatic pump filling via the suction line by opening the drain ports is not possible.
- Always supply the pump with hydraulic fluid from the start. Even just a short period with insufficient hydraulic fluid can damage the pump. Such damage is not immediately visible once the pump is put into operation.
- Never drain the pump.
- Hydraulic fluid which flows back into the tank must not be sucked back in immediately (install baffles!).
- Before first use, run the pump for approx. 10 minutes at max. 50 bar after initial start-up.
- Do not use the entire pressure range of the pump until it has been thoroughly bled and flushed.

- From the start, always keep the temperature within the specified range (see Chapter 3, "Parameters"). Never exceed the maximum temperature.
- Always comply with the cleanliness level of the hydraulic fluid. In addition, filter the hydraulic fluid appropriately (see Chapter 3, "Parameters").
- Self-installed filters in the suction line must be approved beforehand by HAWE Hydraulik.
- A system pressure-limiting valve must be installed in the pressure line so that the maximum system pressure is not exceeded.

5.2.2 Connections

The connecting lines' nominal width depends on:

- the given usage conditions
- viscosity of the hydraulic fluid
- start-up and operating temperature
- pump speed

HAWE recommends: Use hose lines (improved damping characteristics) instead of rigid pipelines.

Bleeding and flushing port	<ul style="list-style-type: none"> ▪ V30D pumps are fitted with two G 1/4 venting and flushing ports. These are used to vent and flush the front shaft bearing in the case of vertical installation.
Pressure connection	<ul style="list-style-type: none"> ▪ Observe the fitting manufacturers' specified tightening torques.
Suction port	<ul style="list-style-type: none"> ▪ The suction port uses SAE ports, see Chapter 4, "Dimensions". Metric mounting threads are used in deviation from the standard. ▪ If possible, route the suction line to the tank on a rising gradient. This allows trapped air to escape. ▪ The absolute suction pressure must not fall below 0.85 bar. ▪ A hose line should generally be used in preference to a rigid pipe line.
Drain port	<ul style="list-style-type: none"> ▪ The pump features 2 drain ports G 1/2, G 3/4 or M33. ▪ The nominal width of the leakage line must not be less than 16 mm. The cross-section is determined by the max. permissible housing pressure. ▪ Integrate the leakage line in the system in such a way as to prevent direct connection with the suction line of the pump. ▪ All drain ports can be used simultaneously. ▪ A separate leakage line from the controller to the tank is not required. Observe the specifications in Chapter 5.2.3, "Installation positions". ▪ The top drain port can be used to fill the housing.
LS port on LS, LSN, LSP, Q and Qb version	<ul style="list-style-type: none"> ▪ The LS line is connected to the controller via a G 1/4" threaded connection. ▪ The nominal width of the line depends on the mounting position of the pump and should be 10% of the pressure line capacity. A hose line should generally be used in preference to a rigid pipe connection. ▪ When the proportional directional spool valve is in neutral position, the LS line must always be fully relieved (controller type LSNR, LSN only)! For controller type LSNRT relief is carried out within the controller.

5.2.3 Installation positions

The variable displacement axial piston pump can be mounted in any installation position.

A support is required for tandem pumps or multiple hydraulic pumps mounted in series (see Chapter 5.2.1, "General information").

Horizontal installation

Pump below the min. fill level

- ▶ For horizontal installation, use the uppermost drain port.

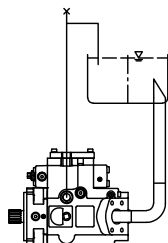

1 Suction port open

Vertical installation

Pump below the min. fill level

- ▶ Mount the pump so that the pump mounting flange is facing upwards.
- ▶ For vertical installation, use the uppermost drain port.
- ▶ Also connect the G 1/8" venting port to the pump flange (see Chapter 4, "Dimensions").
- ▶ Take appropriate measures to ensure continuous venting of this line (line routing/venting).

For installation with pump flange facing downwards: Get in touch with HAWE Hydraulik SE.

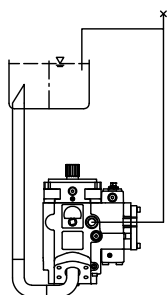

1 Suction port open

5.2.4 Tank installation

Pump below the min. fill level

The pump can be operated either with or without a suction intake. Using a short suction intake is recommended.

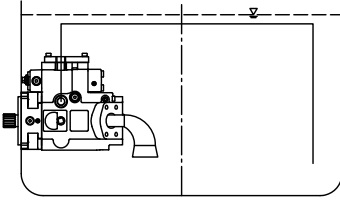

Pump above the fill level

! NOTICE

The pump must not run dry via the pressure, intake, drain, venting or control lines. This applies in particular to long periods of downtime.

- ▶ The leakage line must be installed in the tank in such a way that it ends below the oil level.
- ▶ Facilitate venting of connecting lines via separate vent openings.
- ▶ Adjust the venting sequence to suit the specific installation.
- ▶ If necessary, a gear pump should be provided in order to draw air from the suction line.

Contact form for special consultation on axial piston pump design:

Checklist for variable displacement axial piston pump design: B 7960 checklist

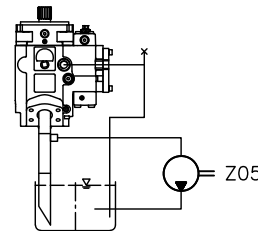
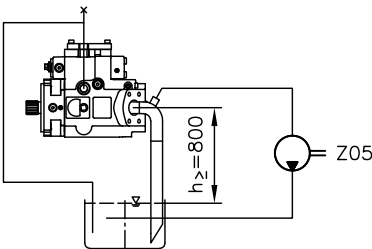

For further information on installation, operation and maintenance, see the relevant assembly instructions: [B 7960](#), [B 5488](#).

5.3 Operating instructions

Observe product configuration and pressure/flow rate.

The statements and technical parameters in this document must be strictly observed.

The instructions for the complete technical system must also always be followed.

! NOTICE

- ▶ Read the documentation carefully before usage.
- ▶ The documentation must be accessible to the operating and maintenance staff at all times.
- ▶ Keep documentation up to date after every addition or update.

! CAUTION

Overloading components due to incorrect pressure settings.

Risk of minor injury. Parts may burst or fly off, and uncontrolled leakage of hydraulic fluid.

- Pay attention to the maximum operating pressure of the pump, valves and fittings.
- Always monitor the pressure gauge when setting and changing the pressure.

Purity and filtering of the hydraulic fluid

Fine contamination can significantly impair the function of the product. Contamination can cause irreparable damage.

Examples of fine contamination include:

- Swarf
- Rubber particles from hoses and seals
- Dirt due to assembly and maintenance
- Mechanical debris
- Chemical ageing of the hydraulic fluid

! NOTICE

New hydraulic fluid from the manufacturer may not have the required purity.

Damage to the product is possible.

- ▶ Filter new hydraulic fluid to a high quality when filling.
- ▶ Do not mix hydraulic fluids. Always use hydraulic fluid that is from the same manufacturer, of the same type, and with the same viscosity properties.

For smooth operation, pay attention to the cleanliness level of the hydraulic fluid (cleanliness level see Chapter 3, "Parameters").

Additionally applicable document: [D 5488/1](#) oil recommendations

Restrictions in operation during cold start phase and warm-up phase

Phase	Temperature	Viscosity (mm ² /s)
Cold start phase	-25 to -40°C	< 1000
Warm-up phase	-25 to 80 °C	500 to 1000
Normal operation	-25 to 80 °C	10 to 500

! NOTICE

Optimum range: 16 - 60 mm²/s

Cold start phase:

- $p_B = 20 - 30$ bar
- $n \leq 1000$ rpm

Warm-up phase:

- $p_B = 20 - 200$ bar
- $n \leq 1500$ rpm

Normal operation:

- No further restrictions. Operating conditions see Chapter 3, "Parameters".

5.3.1 Limitations

For operation with HFC (35 - 50% water content) the following restrictions apply

- tank located above pump
- temperature does not exceed 50°C
- fluid rate in suction line is less than 1 m/s
- pump pressure no more than 200 bar
- each of a pump's two shaft bearings are flushed by their own separate, cool oil, at 2 l/min per bearing (V30D-045/075), 3 l/min per bearing (V30D-095/115), 4 l/min per bearing (V30D-140/160) and 5 l/min per bearing (V30D-250)

For operation with liquids with a water content ≤ 20 % the following restrictions apply

- tank located above pump
- tank temperature does not exceed 70°C
- fluid rate in suction line is less than 1 m/s
- pump pressure no more than 300 bar
- possible without bearing flushing

5.4 Maintenance information

This product is largely maintenance-free.

Check regularly (at least once a year) by visual inspection whether the hydraulic connections are damaged. If external leakages are found, shut down and repair the system.

Clean the surface of the device regularly (at least once a year) (dust deposits and dirt).

6 Other information

6.1 Planning information

Determination of nominal sizes

Delivery flow	$Q = \frac{V_g \cdot n \cdot \eta_V}{1000} \text{ (l/min)}$	Q = Flow rate (l/min)
Drive torque	$M = \frac{V_g \cdot \Delta p}{20 \cdot \pi \cdot \eta_{mh}} \text{ (Nm)}$	M = Torque (Nm)
Drive power	$P = \frac{2\pi \cdot M \cdot n}{60000} = \frac{Q \cdot \Delta p}{600 \cdot \eta_t} \text{ (kW)}$	P = Power (kW)

V_g = Geom. output volume (cm³/rev.)
 Δp = Differential pressure
 n = Speed (rpm)
 η_V = Volumetric efficiency
 η_{mh} = Mechanical-hydraulic efficiency
 η_t = Overall efficiency ($\eta_t = \eta_V \cdot \eta_{mh}$)

References

Additional versions

- Variable displacement axial piston pump type V30E: D 7960 E
- Variable displacement axial piston pump type V60N: D 7960 N
- Fixed displacement axial piston pump type K60N: D 7960 K
- Axial piston pump type K61N: D 7961 K
- Axial piston motors type M60N: D 7960 M
- Proportional directional spool valves types PSL, PSV size 2: D 7700-2
- Proportional directional spool valves types PSL/PSV/PSM, size 3: D 7700-3
- Proportional directional spool valve, type PSL, PSM and PSV size 5: D 7700-5
- D 7700-3F
- D 7700-5F
- Proportional directional spool valve banks type PSLF and PSVF size 7: D 7700-7F
- Load-holding valve type LHT: D 7918
- Load-holding valve type LHDV: D 7770
- Proportional amplifier type EV1M3: D 7831/2
- Proportional amplifier type EV1D: D 7831 D

Operating instructions

- General operating manual for the assembly, initial operation and maintenance of hydraulic components and systems: B 5488

