

Variable displacement axial piston pump type C41V

Product documentation



Open circuit

Nominal pressure $p_{\text{nom max}}$: 280 bar

Peak pressure p_{max} : 350 bar

Displacement volume V_{max} : 85 cm³/rev



© by HAWE Hydraulik SE.

The reproduction and distribution of this document, as well as the use and communication of its contents to others without explicit authorization, is prohibited.

Offenders will be held liable for the payment of damages.

All rights reserved in the event of patent or utility model applications.

Brand names, product names and trademarks are not specifically indicated. In particular with regard to registered and protected names and trademarks, usage is subject to legal provisions.

HAWE Hydraulik respects these legal provisions in all cases.

HAWE Hydraulik cannot provide individual guarantees that the stated circuits or procedures (including in part) are not subject to the intellectual property rights of third parties.

Printing date / document generated on: 2025-01-14

Table of Contents

1	Overview: variable displacement axial piston pump type C41V.....	4
2	Available versions.....	5
2.1	Basic type and nominal size.....	5
2.2	Rotation direction.....	6
2.3	Shaft version.....	6
2.4	Flange version.....	7
2.5	Housing versions.....	7
2.6	Suction and pressure connection.....	8
2.7	Seals.....	9
2.8	Pump controller.....	9
2.9	Additional and solenoid voltage.....	10
2.10	Magnetic plug.....	10
2.11	Stroke limitation.....	10
2.12	Thru-shaft.....	10
2.13	Coupling sleeve for thru-shaft.....	11
3	Parameters.....	12
3.1	General data.....	12
3.2	Weight and weight torque.....	15
3.3	Pressure and delivery flow.....	16
3.4	Characteristic lines.....	16
3.5	Electrical data.....	26
4	Dimensions.....	27
4.1	Basic pump.....	27
4.1.1	C41V 30.28, C41V 30.34.....	27
4.1.2	C41V 48.45, C41V 48.53.....	32
4.1.3	C41V 60.60, C41V 60.72, C41V 60.84.....	36
4.2	Pump controller.....	41
5	Installation, operation and maintenance information.....	43
5.1	Intended use.....	43
5.2	Assembly information.....	43
5.2.1	General information.....	43
5.2.2	Connections.....	44
5.2.3	Installation positions.....	45
5.3	Operating instructions.....	47
5.4	Maintenance information.....	47
6	Other information.....	48
6.1	Planning information.....	48
6.2	Pump controller - Further information.....	49
6.2.1	Pressure controller.....	49
6.2.2	Load-sensing controller.....	53
6.2.3	Power controller.....	56

1**Overview: variable displacement axial piston pump type C41V**

Variable displacement axial piston pumps adjust the geometric output volume from maximum to zero. As a result they vary the flow rate that is provided to the consumers.

The axial piston pump type C41V is designed for open circuits in mobile hydraulics and operates on the swash plate principle.

The large selection of different pump controllers allows the axial piston pump type C41V to be used in a variety of applications.

Features and advantages

- Optimised power-to-weight ratio
- Broad selection of controllers
- High self-suction speed
- Thru-shaft compatibility
- Compact design

Intended applications

- Machines for forestry and agricultural purposes
- Municipal trucks
- Construction machines
- Fan control systems
- Lifting platforms



Variable displacement axial piston pump type C41V

2 Available versions

Circuit symbol

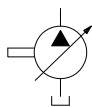

Ordering example

C41V 48.45	D	-05	S5	-L	SD/SB	-N	-PEC	-2	-D	-G	-AS5	/04
2.1 "Basic type and nominal size"	2.2 "Rotation direction"	2.3 "Shaft version"	2.4 "Flange version"	2.5 "Housing versions"	2.6 "Suction and pressure connection"	2.7 "Seals"	2.8 "Pump controller"	2.9 "Additional and solenoid voltage"	2.10 "Magnetic plug"	2.11 "Stroke limitation"	2.12 "Thru-shaft"	2.13 "Coupling sleeve for thru-shaft"

2.1 Basic type and nominal size

Type	Displacement volume V_g (cm ³ /rev)	Nominal pressure p_{nom} (bar)	Peak pressure p_{max} (bar)
C41V 30.28	28	280	350
C41V 30.34	34.8	250	315
C41V 48.45	45	280	350
C41V 48.53	53.7	250	315
C41V 60.60	60	280	350
C41V 60.72	72	280	350
C41V 60.84	84.7	250	315

2.2 Rotation direction

Coding	Description
S	Anticlockwise
D	Clockwise

When looking at the shaft journal.

2.3 Shaft version

Coding	Description	Max. drive torque (Nm)
03	<ul style="list-style-type: none"> ▪ SAE-A J 744 ▪ 9T 16/32 DP ▪ 16-4 ISO 3019-1 ▪ Without undercut <p>Only in combination with C41V 30.28 or C41V 30.34</p>	110
07	<ul style="list-style-type: none"> ▪ 11T 16/32 DP ▪ 19-4 ISO 3019-1 ▪ Without undercut <p>Only in combination with C41V 30.28 or C41V 30.34</p>	170
04	<ul style="list-style-type: none"> ▪ SAE-B J 744 ▪ 13T 16/32 DP ▪ 22-4 ISO 3019-1 ▪ With undercut 	270
4R	<ul style="list-style-type: none"> ▪ SAE-B J 744 ▪ 13T 16/32 DP ▪ 22-4 ISO 3019-1 ▪ Without undercut <p>Only in combination with C41V 30.28, C41V 30.34, C41V 48.45 or C41V 48.53</p>	290
32	<ul style="list-style-type: none"> ▪ SAE-B Parallel key shaft A6.35x6.35x25.4 <p>Only in combination with C41V 30.28, C41V 30.34, C41V 48.45 or C41V 48.53</p>	210
05	<ul style="list-style-type: none"> ▪ SAE-BB J 744 ▪ 15T 16/32 DP ▪ 25-4 ISO 3019-1 ▪ With undercut <p>Only in combination with C41V 48.45, C41V 48.53, C41V 60.60, C41V 60.72 or C41V 60.84</p>	440
5R	<ul style="list-style-type: none"> ▪ SAE-BB J 744 ▪ 15T 16/32 DP ▪ 25-4 ISO 3019-1 ▪ Without undercut <p>Only in combination with C41V 48.45, C41V 48.53, C41V 60.60, C41V 60.72 or C41V 60.84</p>	460
06	<ul style="list-style-type: none"> ▪ SAE-C J 744 ▪ 14T 12/24 DP ▪ 32-4 ISO 3019-1 ▪ With undercut <p>Only in combination with C41V 60.60, C41V 60.72 or C41V 60.84</p>	810

Coding	Description	Max. drive torque (Nm)
6R	<ul style="list-style-type: none"> ▪ SAE-C J 744 ▪ 14T 12/24 DP ▪ 32-4 ISO 3019-1 ▪ Without undercut <p>Only in combination with C41V 60.60, C41V 60.72 or C41V 60.84</p>	880
34	<ul style="list-style-type: none"> ▪ SAE-C Parallel key A7.94x7.94x38.1 <p>Only in combination with C41V 60.60, C41V 60.72 or C41V 60.84</p>	670

2.4 Flange version

Coding	Description
S1	<ul style="list-style-type: none"> ▪ SAE-A 2-Loch J 744 ▪ 82-2 ISO 3019-1 <p>Only in conjunction with shaft version coding 03 or 07</p>
S5	<ul style="list-style-type: none"> ▪ SAE-B 2-Loch J 744 ▪ 101-2 ISO 3019-1 <p>Only in conjunction with shaft version coding 04, 4R, 05, 5R or 32</p>
S7	<ul style="list-style-type: none"> ▪ SAE-C 2-Loch J 744 ▪ 127-2 ISO 3019-1 <p>Only in conjunction with shaft version coding 06, 6R or 34</p>
S8	<ul style="list-style-type: none"> ▪ SAE-C 4-Loch J 744 ▪ 127-4 ISO 3019-1 <p>Only in conjunction with shaft version coding 06, 6R or 34</p>

2.5 Housing versions

Coding	Description
L	Suction and pressure connection radial
P	Suction and pressure connection axial

2.6 Suction and pressure connection

Left rotation direction
(anticlockwise)

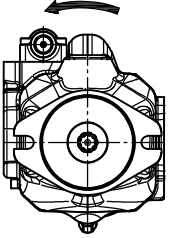

Radial connections

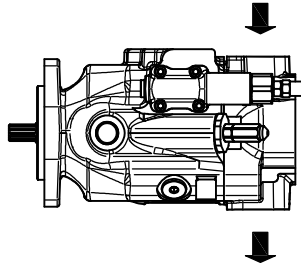

Axial connections

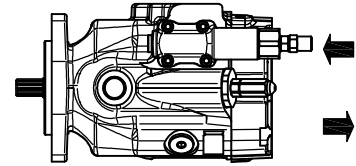

Right rotation direction
(clockwise)

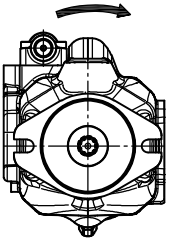

Radial connections

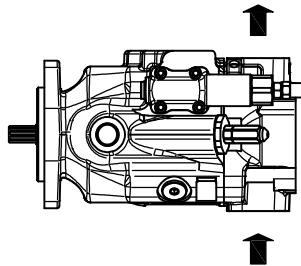

Axial connections

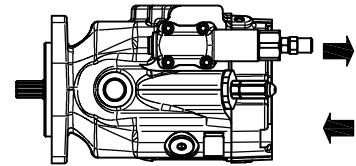

C41V 30..

Coding	Designation
MD/MB	Flange port with metric threads
SD/SB	Flange port with UNC threads
OG/OD	Threaded connection
	Only in combination with housing version coding P

C41V 48..

Coding	Designation
ME/MC	Flange port with metric threads
SE/SC	Flange port with UNC threads
OH/OF	Threaded connection
	Only in combination with housing version coding P

C41V 60..

Coding	Designation
MF/MC	Flange port with metric threads
SF/SC	Flange port with UNC threads
MF/OF	Combination of flange port and threaded connection <ul style="list-style-type: none"> ▪ Suction port: Flange port with metric threads ▪ Pressure connection: Threaded connection

2.7 Seals

Coding	Description
N	NBR
V	FKM

2.8 Pump controller

Pressure controller

Coding	Description
RP0	Mechanically adjustable pressure controller
RP2	2-stage pressure controller with electrical switching between two pressure settings
LS3	Mechanically adjustable pressure controller with remote-control port
PEC	Electro-proportional pressure controller with falling characteristic line

see Chapter 6.2.1, "Pressure controller"

Load-sensing controller

Coding	Description
LS2	Load-sensing controller with integrated pressure limitation (Standard version for combination with hydraulic valves that relieve the LS signal in the valve, for example, type PSV proportional directional spool valve)
LS0	Load-sensing controller with integrated pressure limitation and additional LS relief (only for use with hydraulic valves without their own relief of the LS signal)
RP2-LS2	Combination of load-sensing controller without LS relief (LS2) and 2-stage pressure controller (RP2)

see Chapter 6.2.2, "Load-sensing controller"

Power controller

Coding	Description
RNO	Combination of power controller and load-sensing controller with integrated pressure limitation without LS relief
RN1	Combination of power controller and mechanically adjustable pressure controller
RN2-LS2	Combination of power controller with electrical switching between two torque settings and load-sensing controller with pressure limitation without LS relief
RN2-LS0	Combination of power controller with electrical switching between two torque settings and load-sensing controller with pressure limitation with LS relief

see Chapter 6.2.3, "Power controller"

2.9 Additional and solenoid voltage

Coding	Description	Nominal voltage
1	N/C contact (closed in normal position)	12 V DC
2		24 V DC
6	N/O contact (open in normal position)	12 V DC
7		24 V DC

2.10 Magnetic plug

Coding	Description
D	Deutsch plug (DT04-2P)
S	DIN plug (EN 175 301-803 A)
JT	AMP plug (Junior Timer)

2.11 Stroke limitation

Coding	Description
G	With minimum stroke and maximum stroke limitation

2.12 Thru-shaft

Coding	Description
Without coding	No thru-shaft
AS1	With thru-shaft Flange version: <ul style="list-style-type: none"> ▪ SAE-A 2-Loch J 744 ▪ 82-2 ISO 3019-1 Only in combination with C41V 30.28 or C41V 30.34
AS5	With thru-shaft Flange version: <ul style="list-style-type: none"> ▪ SAE-B 2-Loch J 744 ▪ 101-2 ISO 3019-1

2.13 Coupling sleeve for thru-shaft

Coding	Description	Max. output torque (Nm)
03	<ul style="list-style-type: none"> ▪ SAE-A J 744 ▪ 9T 16/32 DP ▪ 16-4 ISO 3019-1 <p>Only in conjunction with thru-shaft version coding AS1</p>	100
31	<p>SAE-A Parallel key shaft with $\varnothing 16$ Only in conjunction with thru-shaft version coding AS1</p>	70
04	<ul style="list-style-type: none"> ▪ SAE-B J 744 ▪ 13T 16/32 DP ▪ 22-4 ISO 3019-1 <p>Only in conjunction with thru-shaft version coding AS5</p>	<ul style="list-style-type: none"> ▪ C41V 30.28 and C41V 30.34: 100 ▪ C41V 48.45, C41V 48.53, C41V 60.60, C41V 60.72 and C41V 60.84: 200
32	<p>SAE-B Parallel key shaft with $\varnothing 22$ Only in conjunction with thru-shaft version coding AS5 and with</p> <ul style="list-style-type: none"> – C41V 30.28 – C41V 30.34 – C41V 48.45 – or C41V 48.53 	<ul style="list-style-type: none"> ▪ C41V 30.28 and C41V 30.34: 100 ▪ C41V 48.45 and C41V 48.53: 250
05	<ul style="list-style-type: none"> ▪ SAE-BB J 744 ▪ 15T 16/32 DP ▪ 25-4 ISO 3019-1 <p>Only in conjunction with thru-shaft version coding AS5 and with</p> <ul style="list-style-type: none"> – C41V 48.45 – C41V 48.53 – C41V 60.60 – C41V 60.72 – or C41V 60.84 	250
33	<p>SAE-BB Parallel key shaft with $\varnothing 25$ Only in conjunction with thru-shaft version coding AS5 and with</p> <ul style="list-style-type: none"> – C41V 48.45 – or C41V 48.53 	250
06	<ul style="list-style-type: none"> ▪ SAE-C J 744 ▪ 14T 12/24 DP ▪ 32-4 ISO 3019-1 <p>Only in conjunction with thru-shaft version coding AS5 and with</p> <ul style="list-style-type: none"> – C41V 60.60 – C41V 60.72 – or C41V 60.84 	430

3.1 General data

Designation	Variable displacement axial piston pump
Pump version	Axial piston pump according to the swash plate principle
Mounting	DIN ISO 3019-1, SAE J 744
Surface	painted
Installation position	As desired Installation information see Chapter 5, "Installation, operation and maintenance information"
Rotation direction	<ul style="list-style-type: none"> ▪ right ▪ left
Ports/connections	<ul style="list-style-type: none"> ▪ Suction port ▪ Pressure connection ▪ Drain port ▪ LS port or remote-control port
Hydraulic fluid	Hydraulic fluid, according to DIN 51524 Parts 1 to 3; ISO VG 10 to 68 according to DIN ISO 3448 Viscosity range: 10 - 1500 mm ² /s Optimal operating range: approx. 15 - 35 mm ² /s see Chapter 5.3, "Operating instructions"
Cleanliness level	ISO 4406 <u>19/17/14</u>
Temperatures	Environment: approx. -40 to +60 °C, hydraulic fluid: -25 to +80 °C, pay attention to the viscosity range. Start temperature: down to -40 °C is permissible (take account of the start viscosities!), as long as the steady-state temperature is at least 20 K higher during subsequent operation.

Designation		Nominal size							
		30.28	30.34	48.45	48.53	60.60	60.72	60.84	
Absolute inlet pressure required in open circuit	bar	0.8	0.8	0.8	0.8	0.8	0.8	0.8	
Max. permissible housing pressure (static/dynamic)	bar	1.5	1.5	1.5	1.5	1.5	1.5	1.5	
Max. permissible inlet pressure (static/dynamic)	bar	25	25	25	25	25	25	25	
Max. rotation speed during suction operation and max. swash plate angle at 1 bar abs. inlet pressure	min ⁻¹	3500	2900	3000	2500	3000	2700	2300	
Max. rotation speed with zero stroke and 1 bar abs. inlet pressure	min ⁻¹	3500	3500	3000	3000	3000	3000	3000	
Required drive torque at $V_{g \max}$ and p_{nom}	Nm	124.8	138.5	200.5	213.7	267.4	320.9	337	
Drive power at $V_{g \max}$, n_{max} and p_{nom}	kW	45.7	42.1	63	55.9	84	90.7	81	
Inertia torque	kg m ²	0.002	0.002	0.003	0.003	0.008	0.008	0.008	
Fill volume	l	0.85	0.85	1.0	1.0	1.3	1.3	1.3	
Max. permissible force on drive shaft	F_{ax} axial force	N	1000	1000	1500	1500	2000	2000	2000
	F_{rad} radial force	N	1500	1500	1500	1500	3000	3000	3000

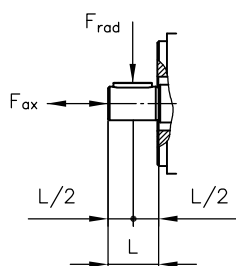

Maximum rotation speed depending on the inlet pressure and displacement volume

Inlet pressure absolute (bar)	Displacement volume (% of $V_{g \max}$)					Rotation speed (% of n_{max})
	65	70	80	90	100	
0.8	120	115	105	97	90	
0.9	120	120	110	103	95	
1.0	120	120	115	107	100	
1.2	120	120	120	113	106	
1.4	120	120	120	120	112	
1.6	120	120	120	120	117	
2.0	120	120	120	120	120	

Max. rotation speed with zero stroke and 1 bar abs. Inlet pressure (see Chapter 3.1, "General data") must not be exceeded.

Example 1:

- Displacement volume: 100%
- Rotation speed: 100%
- Inlet pressure abs.: 1.0 bar

Example 2:

- Displacement volume: 80%
- Inlet pressure abs.: 1.0 bar
- Rotation speed: 115%

Example 3:

- Displacement volume: 100%
- Inlet pressure abs.: 1.4 bar
- Rotation speed: 112%

Setting for the minimum and maximum stroke limitation

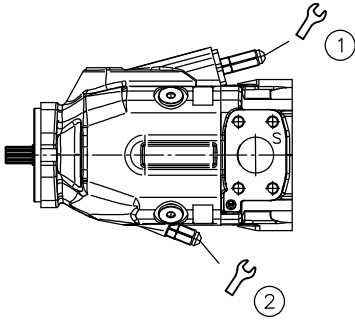

- 1 Maximum stroke limitation
- 2 Minimum stroke limitation

🔑 Tightening torque 15 ±1 Nm			C41V 30..	C41V 48..	C41V 60..
Adjustment range for maximum stroke limitation	cm ³ /rev		14 - 34	34 - 53	53 - 84
Adjustment range for minimum stroke limitation	cm ³ /rev		0 - 14	0 - 10.7	0 - 38.1
Change of the setting value per revolution of the adjusting screw	cm ³ /rev	Maximum stroke limitation	approx. 2.8	approx. 3.2	approx. 5.0
		Minimum stroke limitation	approx. 2.3	approx. 3.0	approx. 4.2

3.2 Weight and weight torque

Weight

Basic pump	Nominal size	
	30.28	= 15 kg
	30.34	= 15 kg
	48.45	= 19 kg
	48.53	= 19 kg
	60.60	= 22 kg
	60.72	= 22 kg
	60.84	= 22 kg

Weight torque

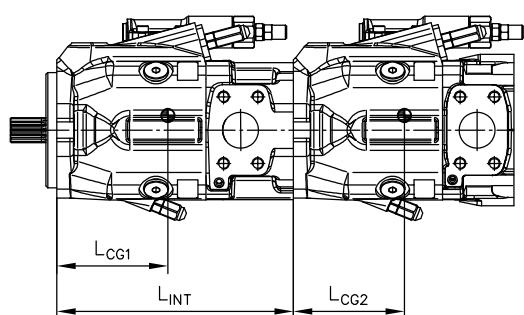

= Centre of gravity

$$M_{MF} = \frac{L_{CG1} \cdot m_1 + (L_{INT} + L_{CG2}) \cdot m_2}{102} \text{ [Nm]}$$

M_{MF} = Weight torque at the front flange

L_{CG} = Distance of the centre of gravity from the front flange (mm)

m = Weight (kg)

Type	L_{CG1} (mm)	L_{CG2} (mm)	L_{INT} (mm)
C41V 30.28 C41V 30.34	100	90	208
C41V 48.45 C41V 48.53	116	99	233
C41V 60.60 C41V 60.72 C41V 60.84	120	107	253

For single pumps: Use L_{CG2} values

Average values: Precise values for specific configurations available on request

3.3 Pressure and delivery flow

Operating pressure see Chapter 2, "Available versions"

Displacement volume see Chapter 2, "Available versions"

3.4 Characteristic lines

Viscosity of the hydraulic fluid approx. 40 mm²/s

Delivery flow and power

C41V 30.28

- 1 1500 min⁻¹
- 2 2000 min⁻¹
- 3 3500 min⁻¹

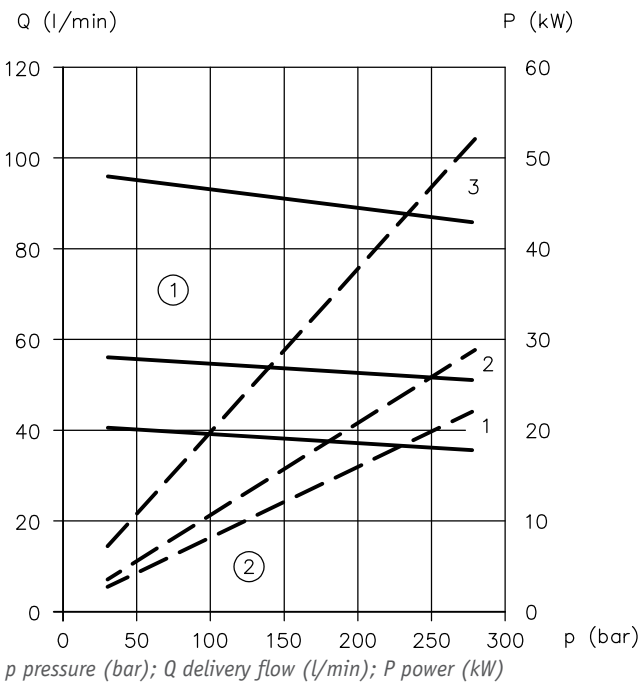

- ① Delivery flow/pressure
- ② Drive power/pressure (max. swash plate angle)

C41V 30.34

- 1 1500 min⁻¹
- 2 2000 min⁻¹
- 3 2900 min⁻¹

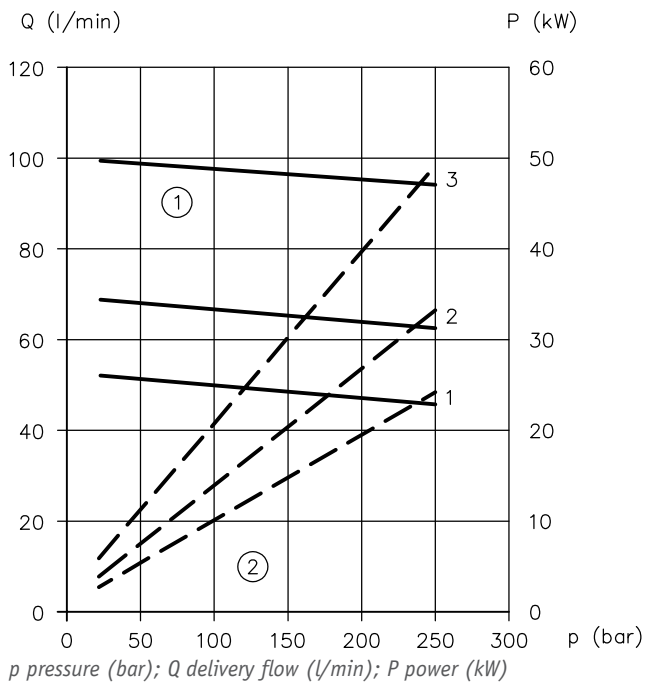

- ① Delivery flow/pressure
- ② Drive power/pressure (max. swash plate angle)

C41V 48.45

- 1 1500 min⁻¹
- 2 2000 min⁻¹
- 3 3000 min⁻¹

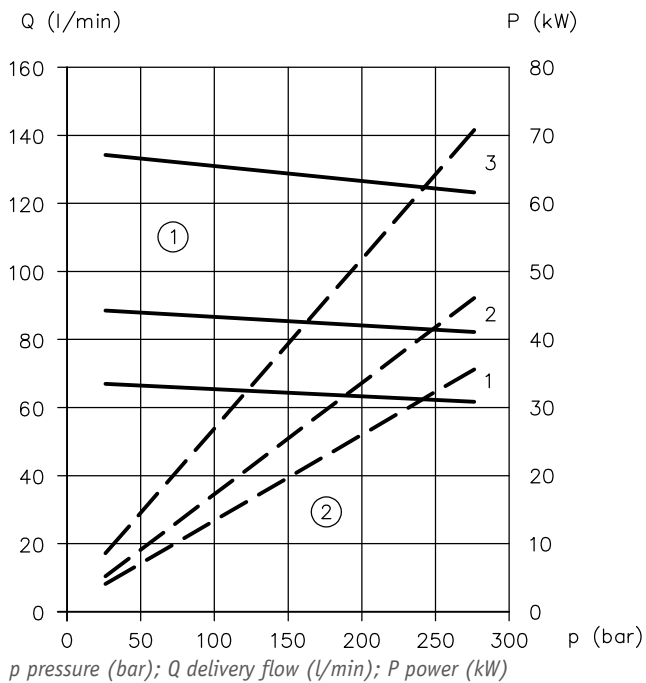

- ① Delivery flow/pressure
- ② Drive power/pressure (max. swash plate angle)

C41V 48.53

- 1 1500 min⁻¹
- 2 2000 min⁻¹
- 3 2500 min⁻¹

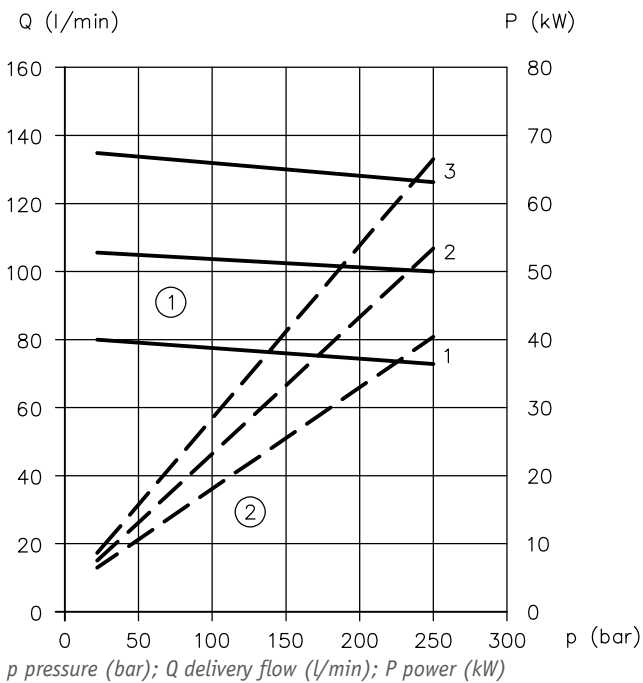

- ① Delivery flow/pressure
- ② Drive power/pressure (max. swash plate angle)

C41V 60.60

- 1 1500 min⁻¹
- 2 2000 min⁻¹
- 3 3000 min⁻¹

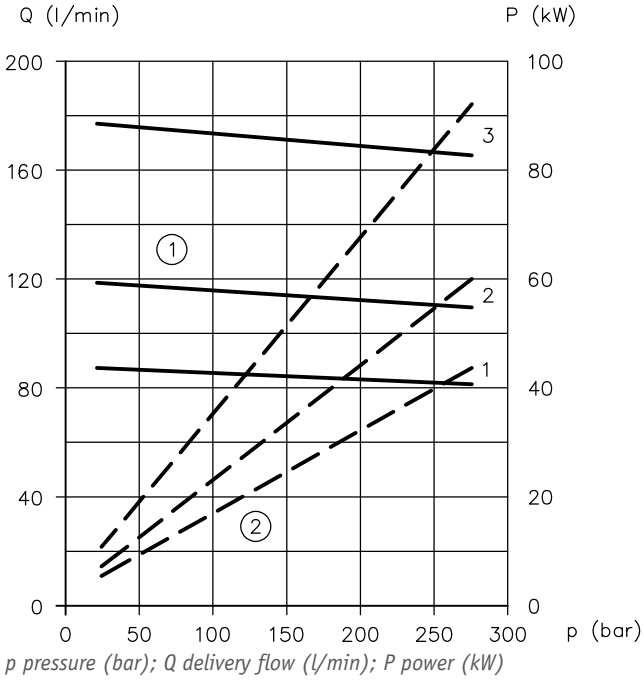

- ① Delivery flow/pressure
- ② Drive power/pressure (max. swash plate angle)

C41V 60.72

- 1 1500 min⁻¹
- 2 2000 min⁻¹
- 3 2700 min⁻¹

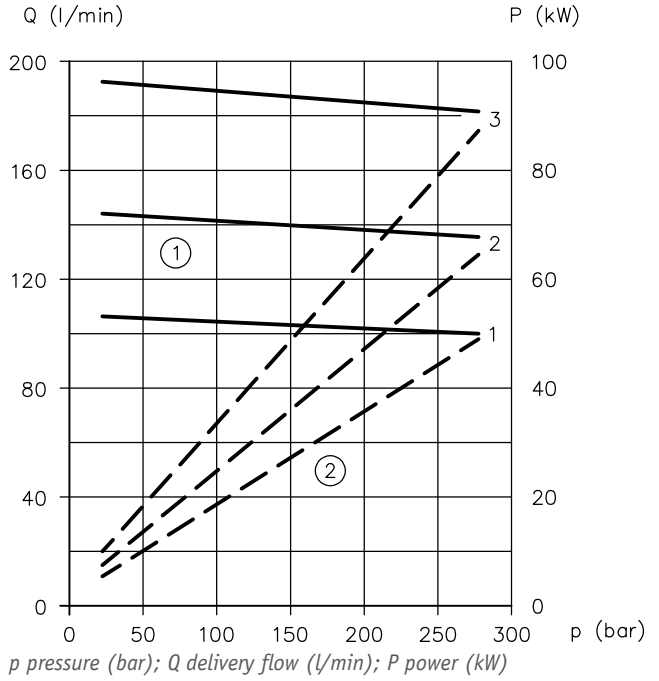

- ① Delivery flow/pressure
- ② Drive power/pressure (max. swash plate angle)

C41V 60.84

- 1 1500 min⁻¹
- 2 2000 min⁻¹
- 3 2300 min⁻¹

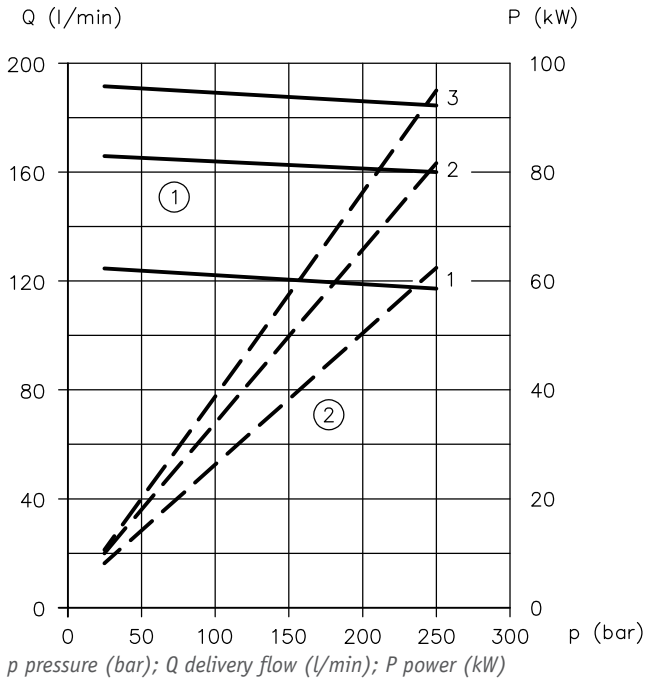

- ① Delivery flow/pressure
- ② Drive power/pressure (max. swash plate angle)

Noise level

The diagrams show the noise level measured in the acoustic measurement chamber as per ISO 3744, distance between sound receiver and pump (d) = 1 m

C41V 30.28

dB (A)

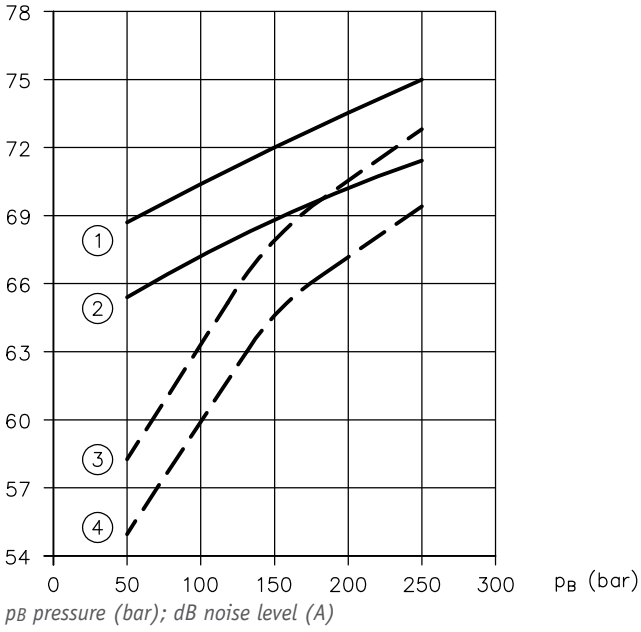

- 1 Vg max at n = 2000 min⁻¹
- 2 Vg max at n = 1500 min⁻¹
- 3 Vg min at n = 2000 min⁻¹
- 4 Vg min at n = 1500 min⁻¹

C41V 30.34

dB (A)

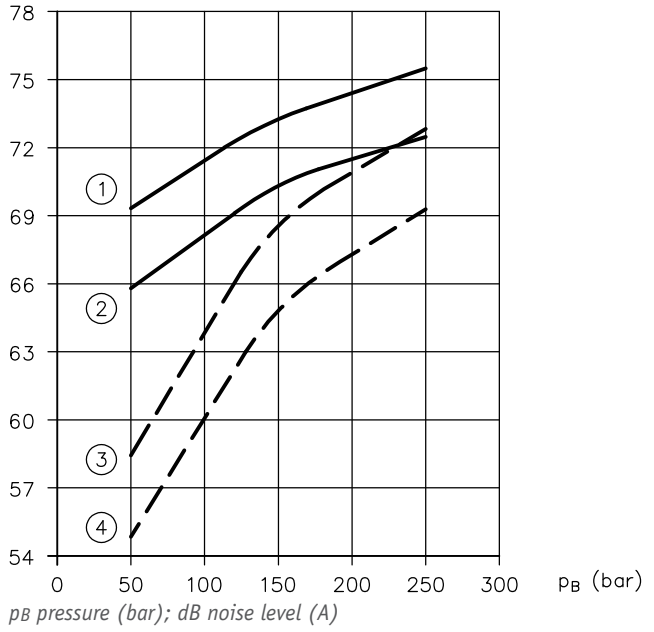

- 1 Vg max at n = 2000 min⁻¹
- 2 Vg max at n = 1500 min⁻¹
- 3 Vg min at n = 2000 min⁻¹
- 4 Vg min at n = 1500 min⁻¹

C41V 48.45

dB (A)

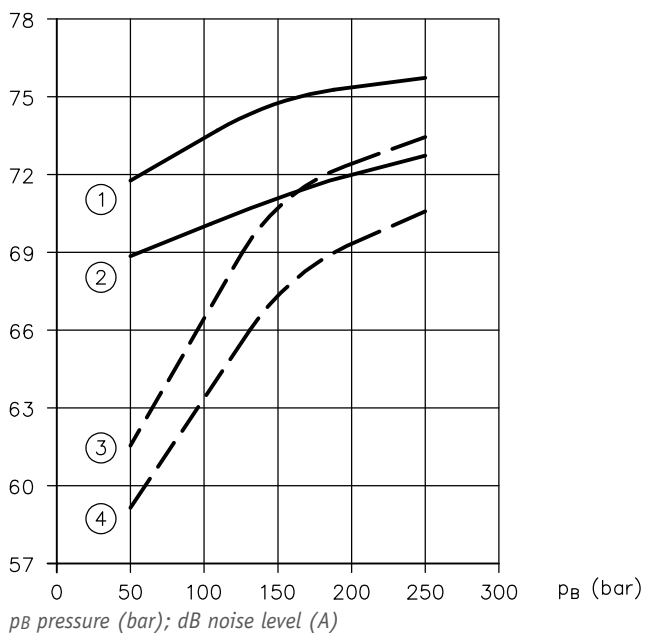

- 1 V_g max at $n = 2000 \text{ min}^{-1}$
- 2 V_g max at $n = 1500 \text{ min}^{-1}$
- 3 V_g min at $n = 2000 \text{ min}^{-1}$
- 4 V_g min at $n = 1500 \text{ min}^{-1}$

C41V 48.53

dB (A)

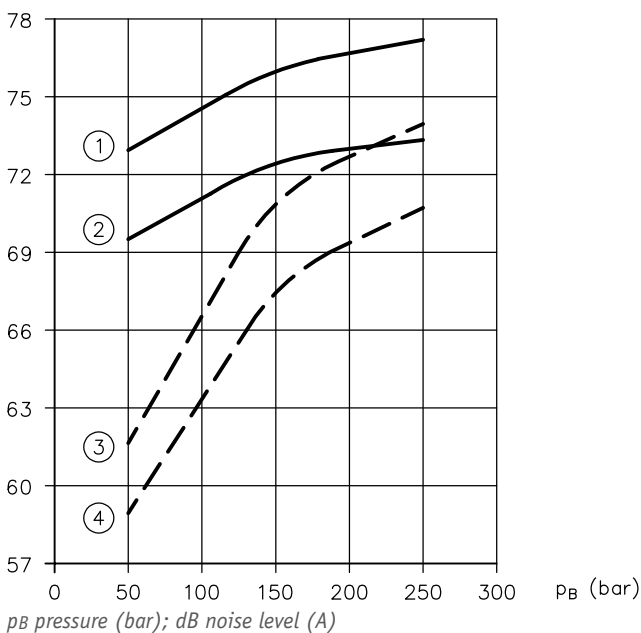

- 1 V_g max at $n = 2000 \text{ min}^{-1}$
- 2 V_g max at $n = 1500 \text{ min}^{-1}$
- 3 V_g min at $n = 2000 \text{ min}^{-1}$
- 4 V_g min at $n = 1500 \text{ min}^{-1}$

C41V 60.60

dB (A)

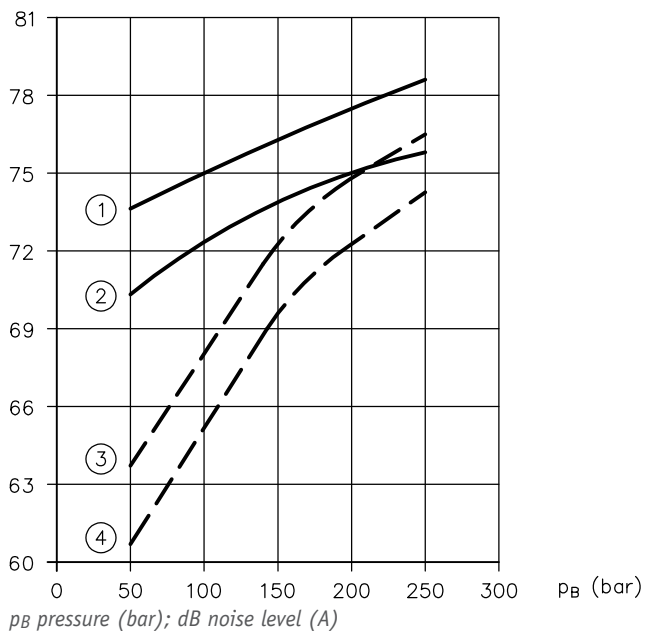

- 1 V_g max at $n = 2000 \text{ min}^{-1}$
- 2 V_g max at $n = 1500 \text{ min}^{-1}$
- 3 V_g min at $n = 2000 \text{ min}^{-1}$
- 4 V_g min at $n = 1500 \text{ min}^{-1}$

C41V 60.72

dB (A)

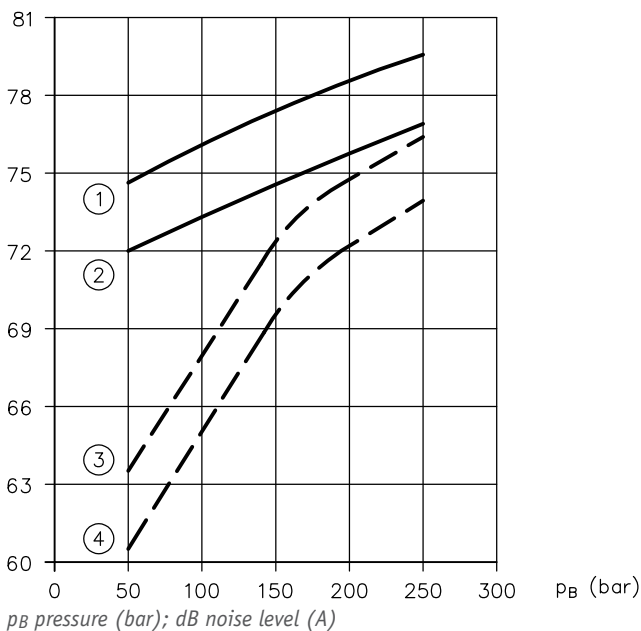

- 1 V_g max at $n = 2000 \text{ min}^{-1}$
- 2 V_g max at $n = 1500 \text{ min}^{-1}$
- 3 V_g min at $n = 2000 \text{ min}^{-1}$
- 4 V_g min at $n = 1500 \text{ min}^{-1}$

C41V 60.84

dB (A)

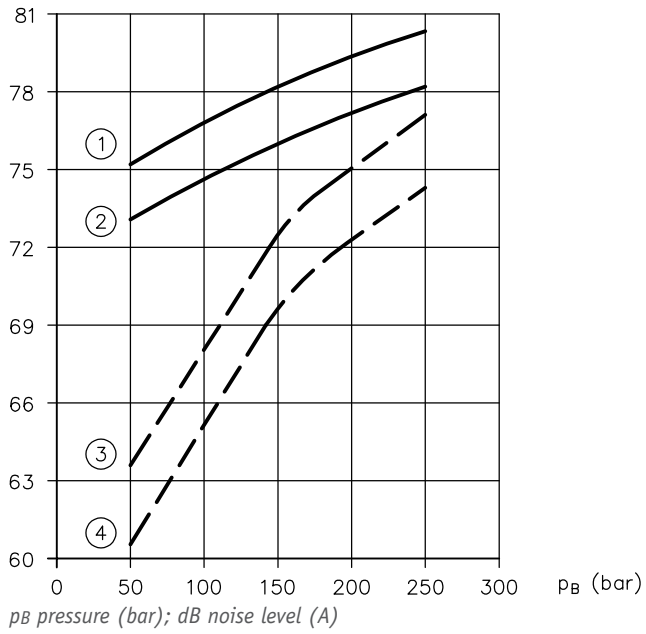

- 1 V_g max at n = 2000 min⁻¹
- 2 V_g max at n = 1500 min⁻¹
- 3 V_g min at n = 2000 min⁻¹
- 4 V_g min at n = 1500 min⁻¹

Efficiency

The diagrams show the volumetric efficiency and the total efficiency as a percentage value in each case, measured at maximum displacement volume.

C41V 30.28

Volumetric efficiency

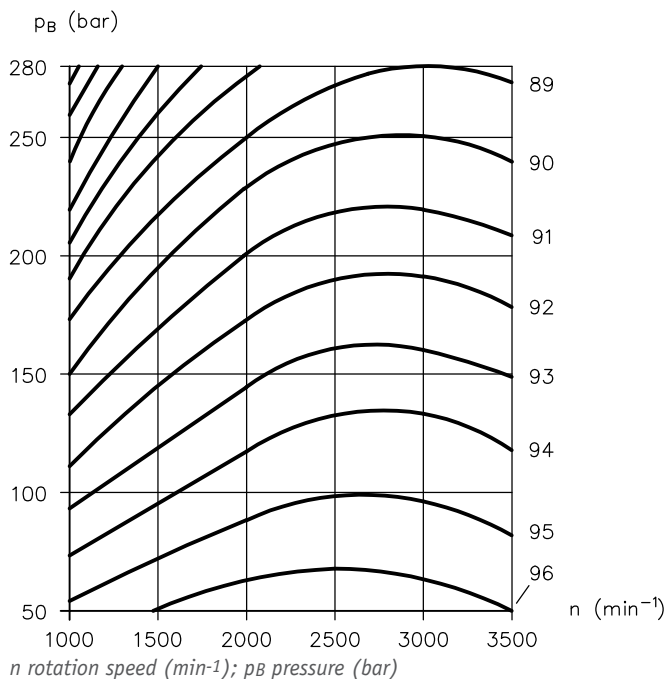

Total efficiency

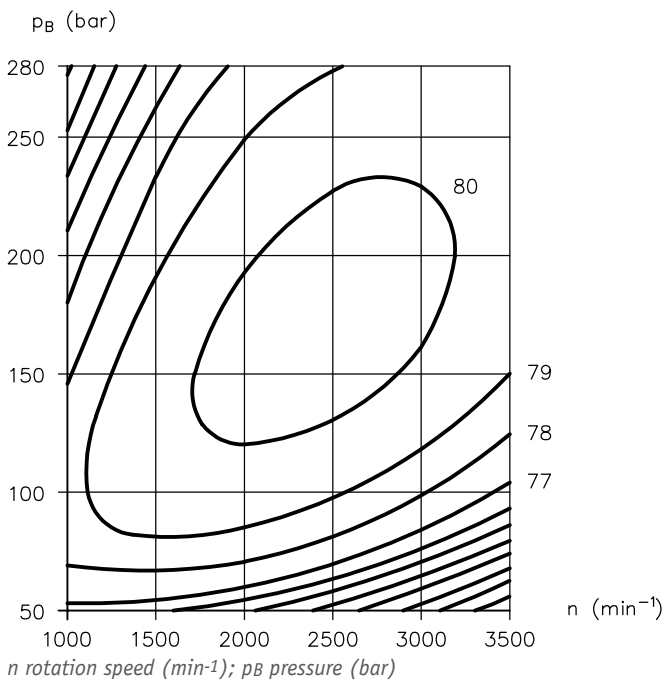

C41V 30.34

Volumetric efficiency

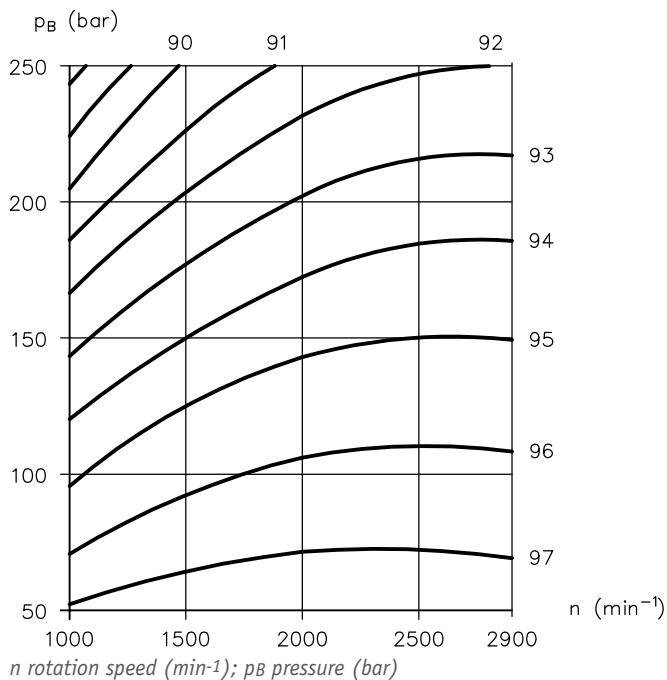

Total efficiency

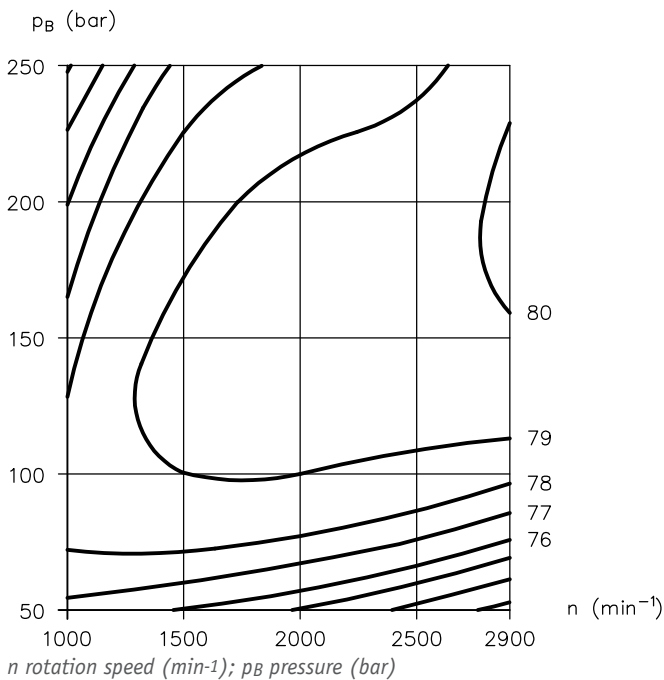

C41V 48.45

Volumetric efficiency

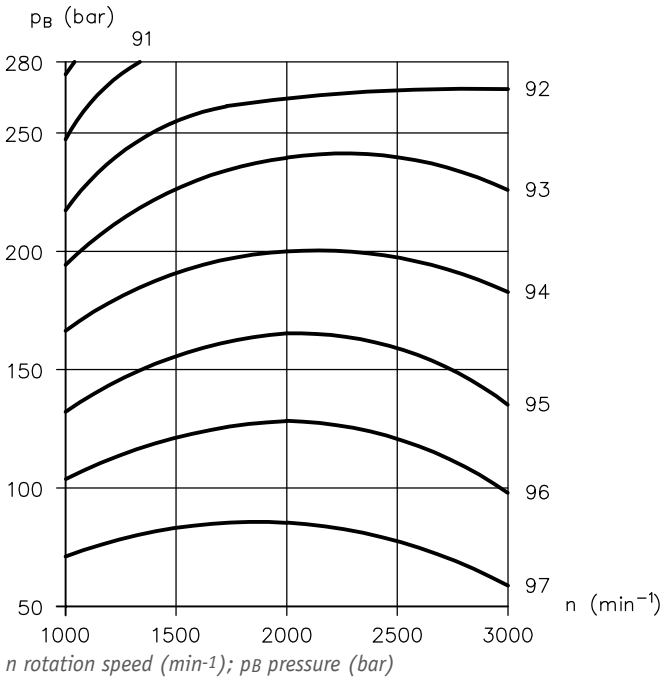

Total efficiency

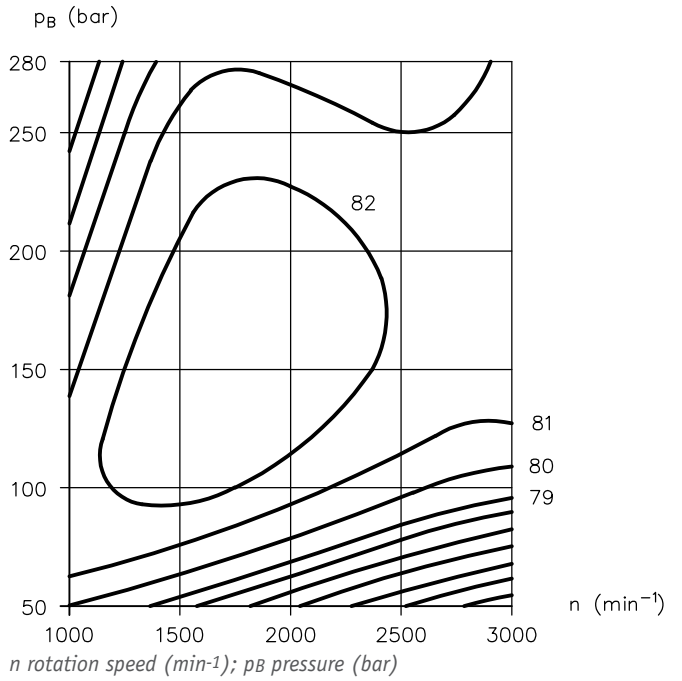

C41V 48.53

Volumetric efficiency

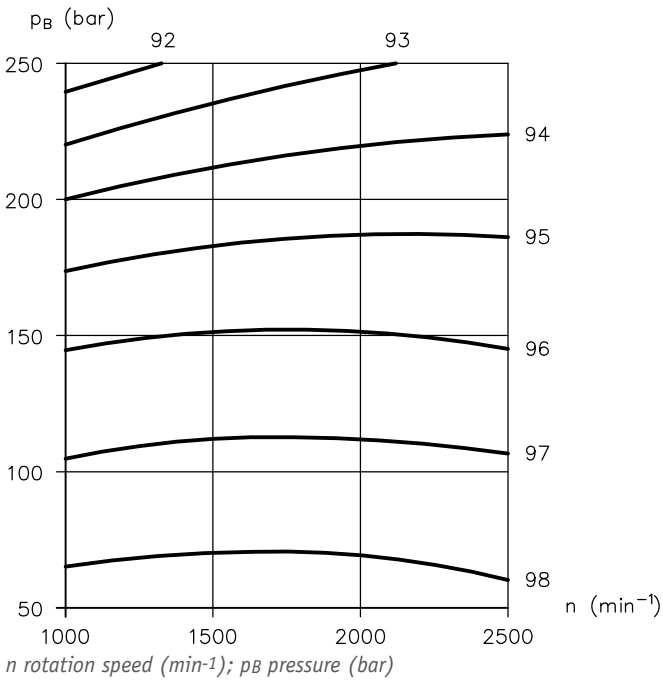

Total efficiency

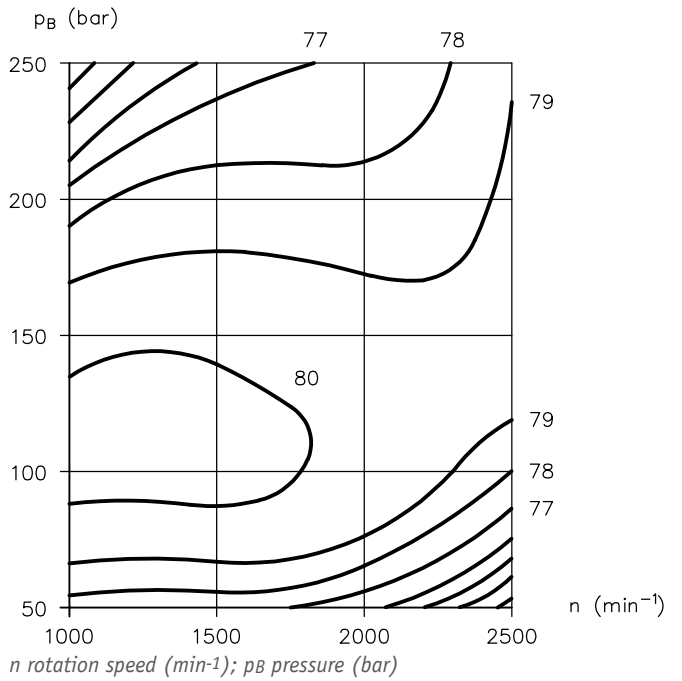

C41V 60.60

Volumetric efficiency

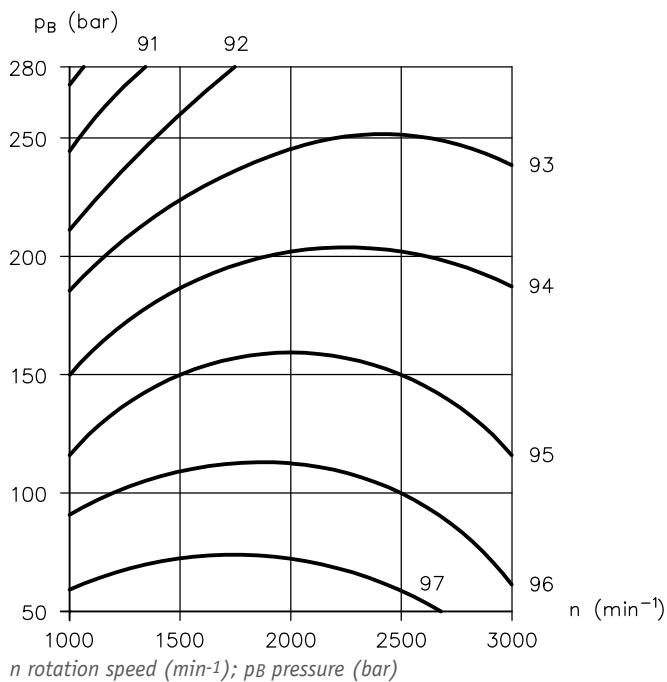

Total efficiency

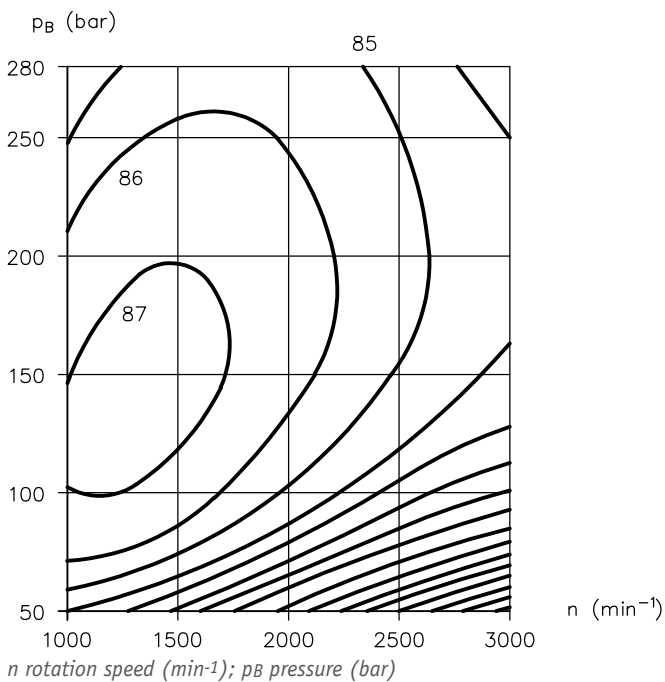

C41V 60.72

Volumetric efficiency

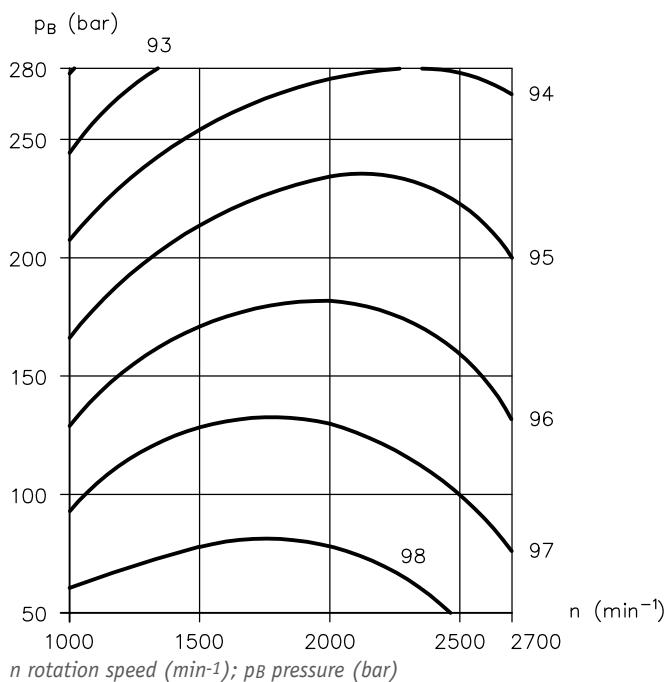

Total efficiency

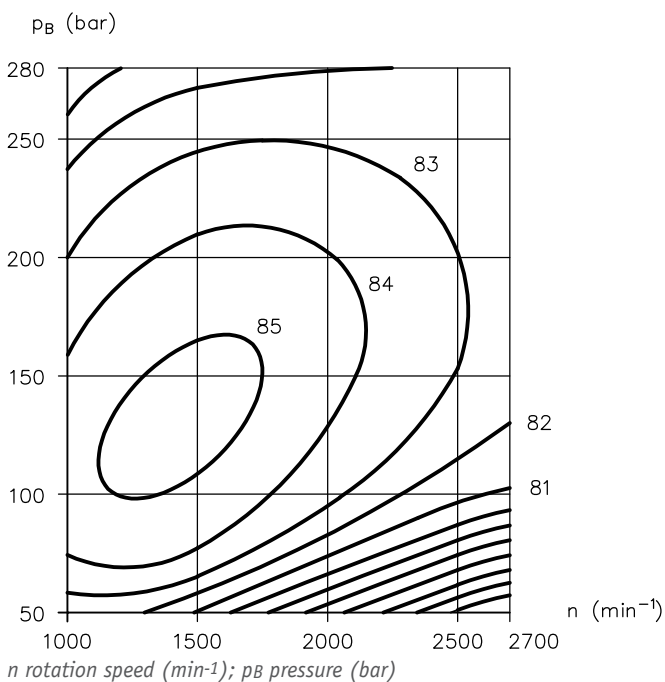

C41V 60.84

Volumetric efficiency

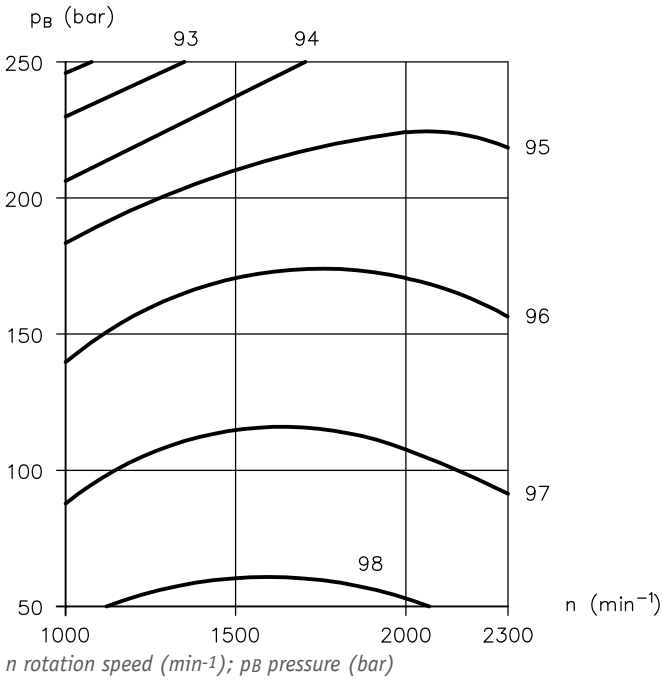

Total efficiency

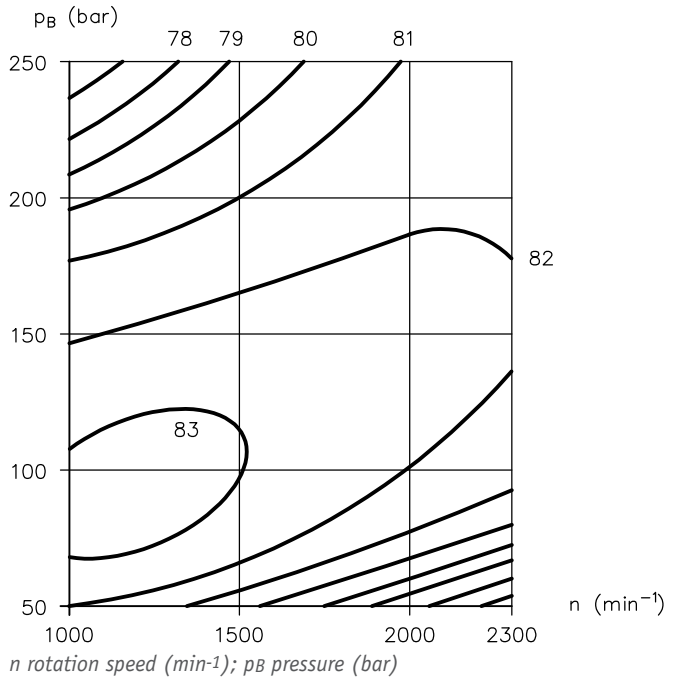

3.5 Electrical data

Nominal voltage	12 V DC	24 V DC
Resistance R_{20}	$4.9 \Omega \pm 3\%$	$17.1 \Omega \pm 5\%$
Current, cold I_{20}	2450 mA	1400 mA
Power P	30 W	34 W
Duty cycle	S1 (100%)	
Dither frequency	150 Hz	
Dither amplitude $A_D(\%) = \frac{I_{\text{Peak-Peak}}}{I_G} \cdot 100$	$20\% \leq A_D \leq 40\%$	
Permissible ambient temperature	-30°C to $+110^\circ\text{C}$	
Protection class in accordance with DIN VDE 0470 when mounted and plugged in	Coding for magnetic plug <ul style="list-style-type: none"> ▪ D: IP 69K ▪ S: IP 65 ▪ JT: IP 67 	

4 Dimensions

All dimensions in mm, subject to change.

4.1 Basic pump

4.1.1 C41V 30.28, C41V 30.34

Version with radial connections without thru-shaft

Clockwise rotation direction
(viewed from shaft journal)

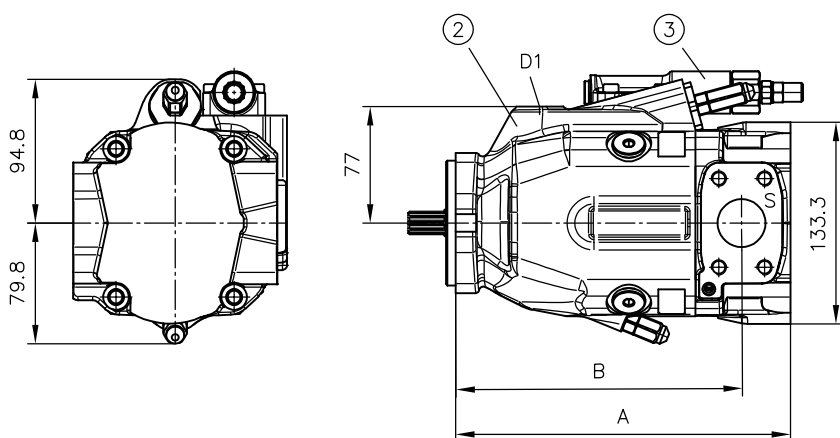

Anticlockwise rotation direction
(viewed from shaft journal)

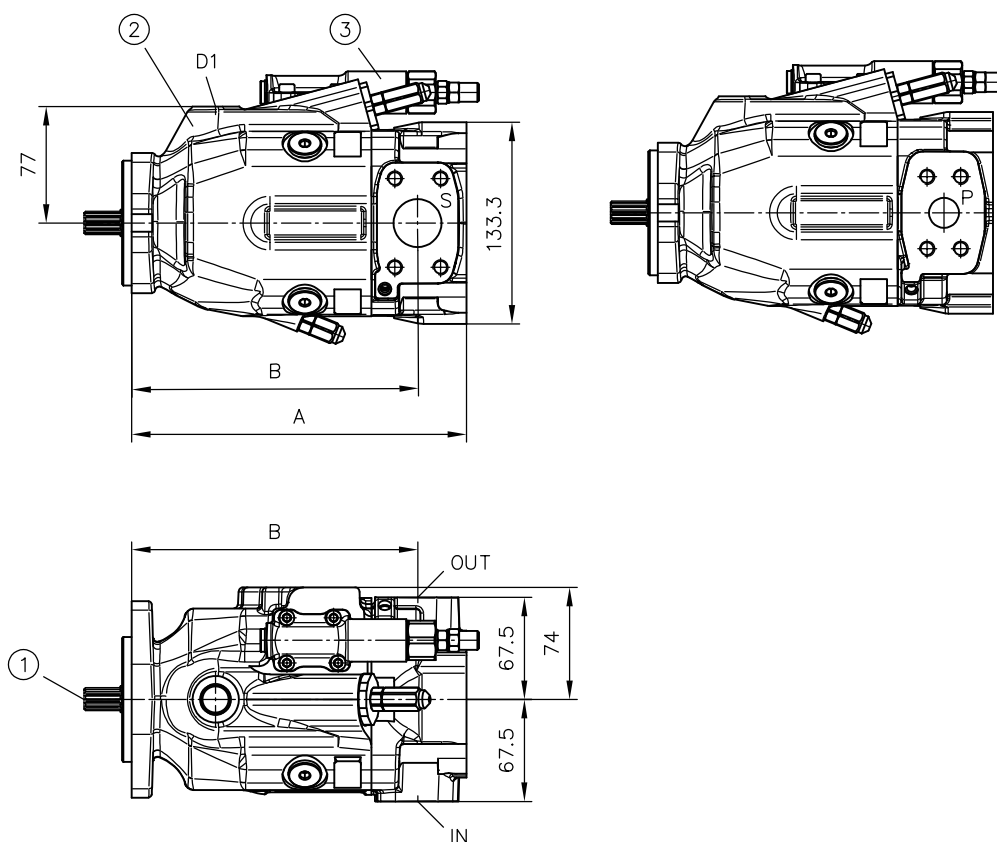

- 1 Shaft version
- 2 Flange version
- 3 Controller

Coding	A	B
S1	221.5	189.2
S5	194.5	162.2

Version with axial connections

Clockwise rotation direction
(viewed from shaft journal)

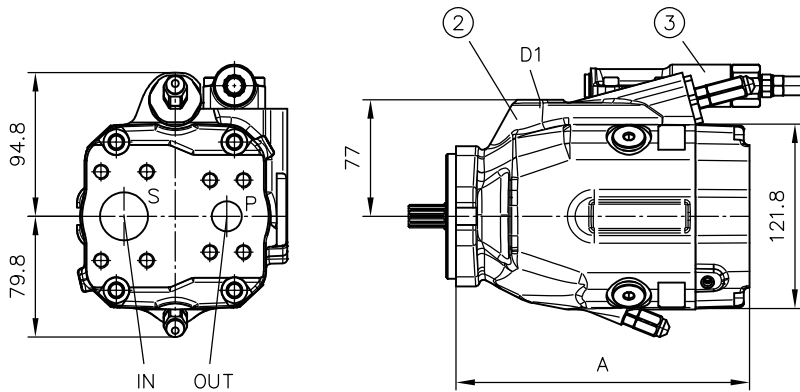

Anticlockwise rotation direction
(viewed from shaft journal)

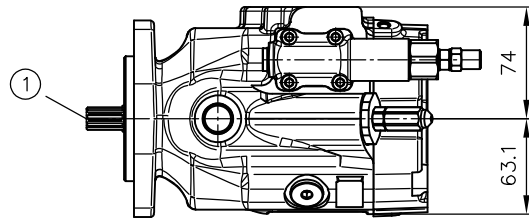
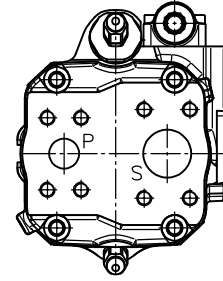

- 1 Shaft version
- 2 Flange version
- 3 Controller

Coding	A
S1	194.2
S5	167.2

Flange version

Coding **S1**

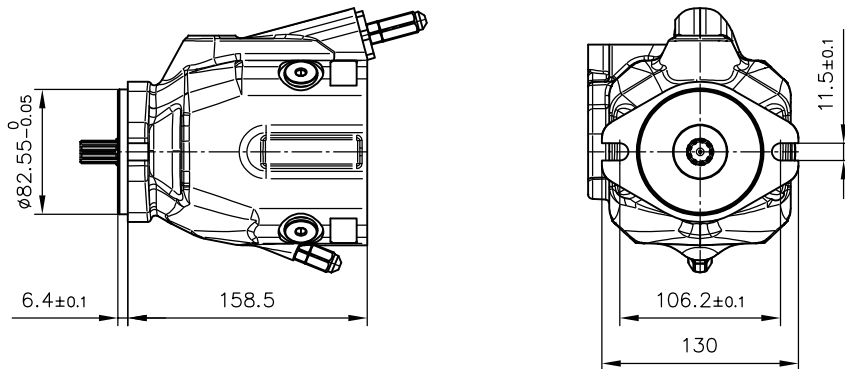

Coding **S5**

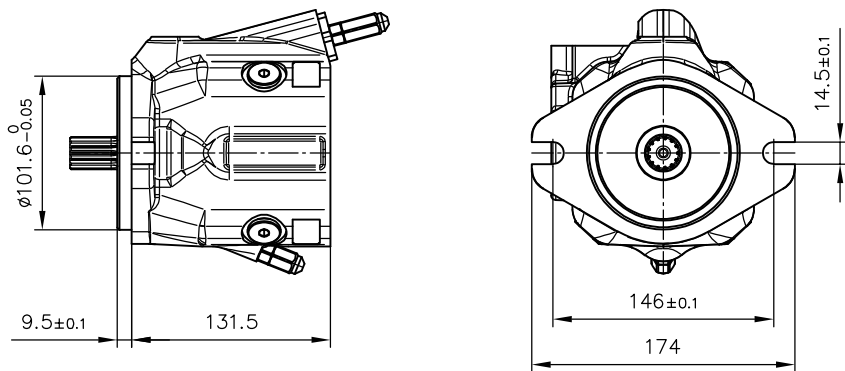

Shaft version

Coding 03

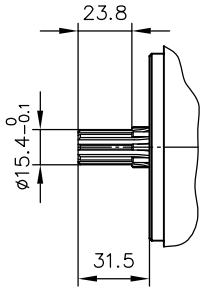

Coding 07

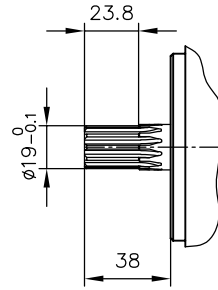

Coding 04

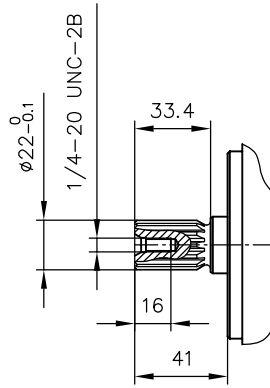

Coding 4R

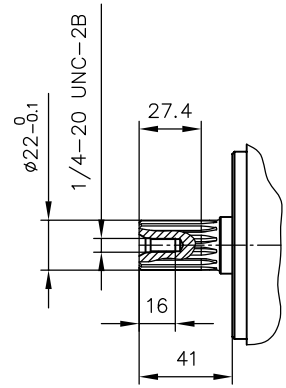

Coding 32

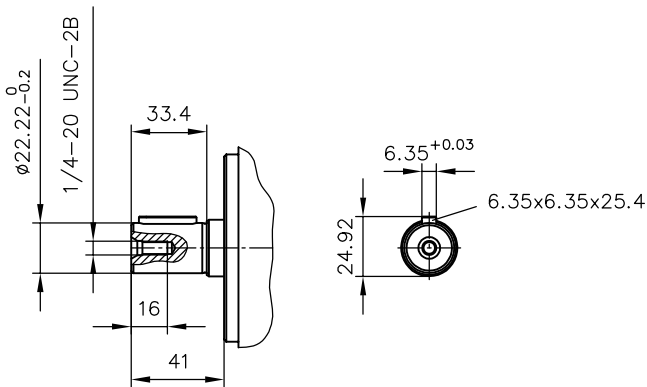

Suction and pressure connection

Suction port S

Coding MD, SD

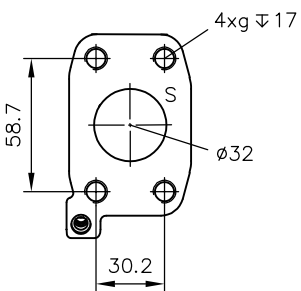

Pressure connection P

Coding MB, SB

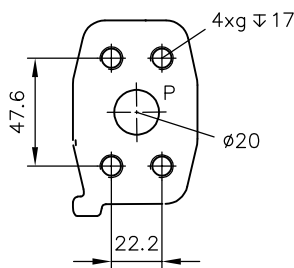

Coding	g
MD	M10
SD	7/16-14 UNC-2B

Coding	g
MB	M10
SB	3/8-16 UNC-2B

Suction and pressure connection for axial connections

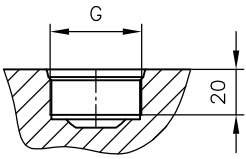

Coding	G
Suction port S	
0G	1 5/8"-12 UNF-2B
Pressure connection P	
0D	1 1/16"-12 UNF-2B

Version with radial connections with thru-shaft

Coding AS1

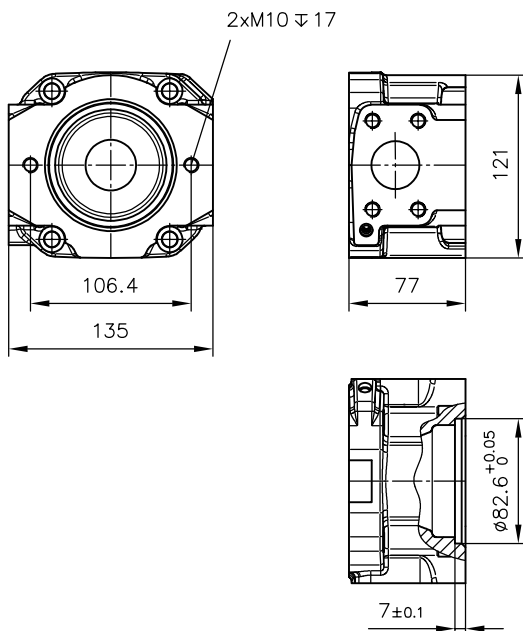

Coding AS5

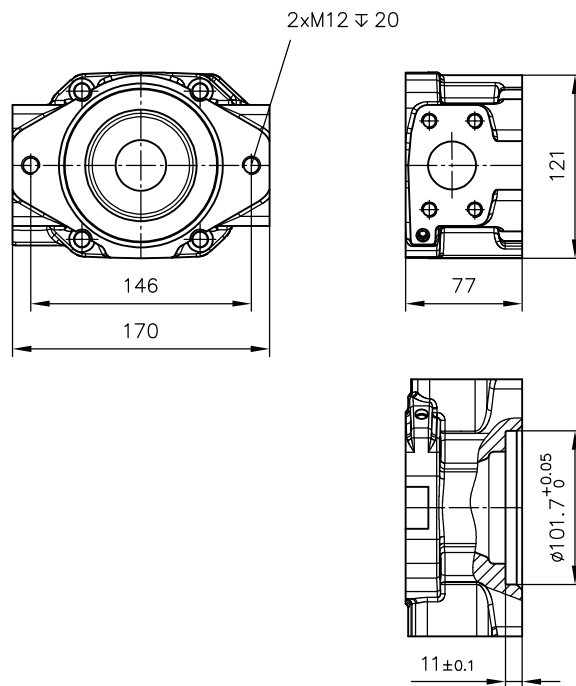

4.1.2 C41V 48.45, C41V 48.53

Version with radial connections without thru-shaft

Clockwise rotation direction
(viewed from shaft journal)

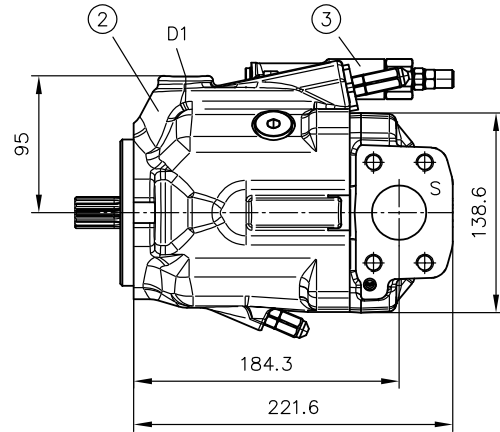
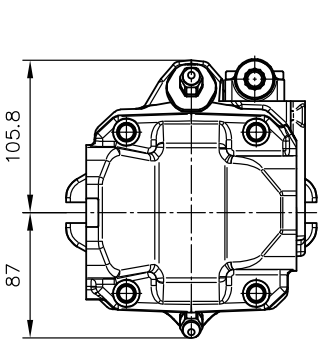

Anticlockwise rotation direction
(viewed from shaft journal)

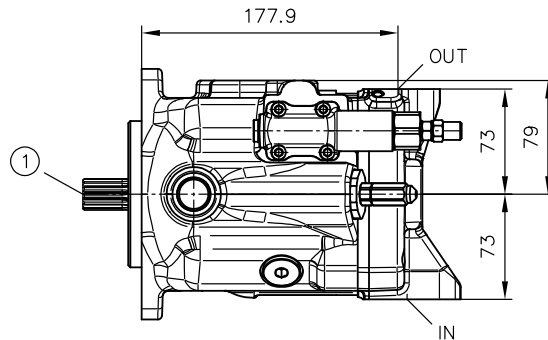
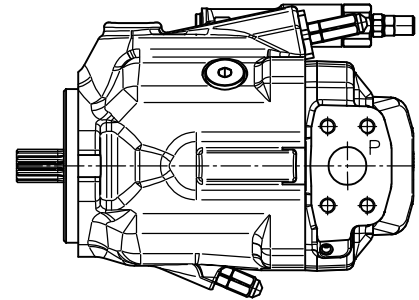

- 1 Shaft version
- 2 Flange version
- 3 Controller

Version with axial connections

Clockwise rotation direction
(viewed from shaft journal)

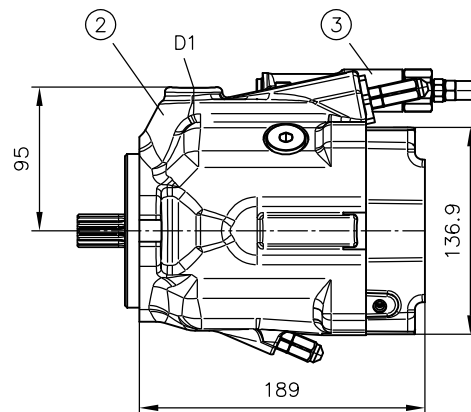
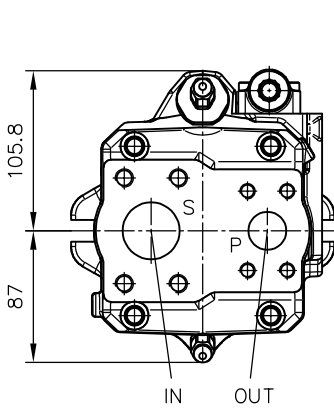

Anticlockwise rotation direction
(viewed from shaft journal)

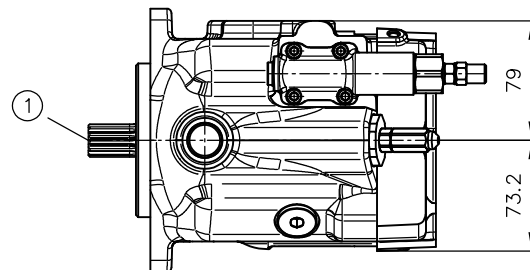
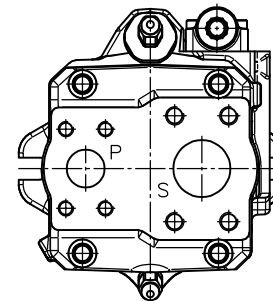

- 1 Shaft version
- 2 Flange version
- 3 Controller

Flange version

Coding S5

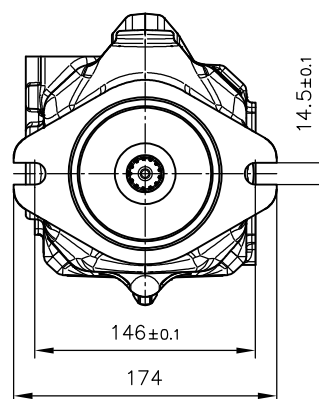
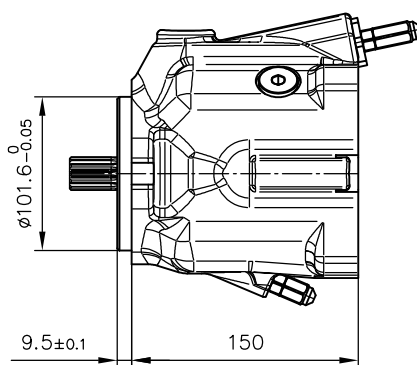

Shaft version

Coding 04

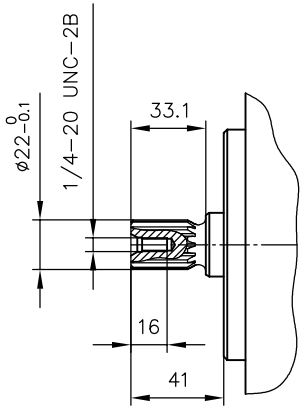

Coding 4R

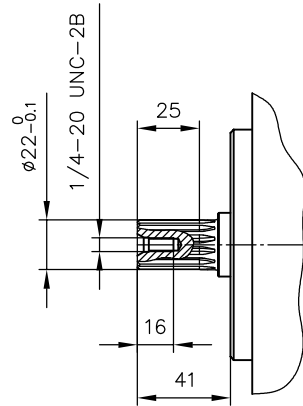

Coding 05

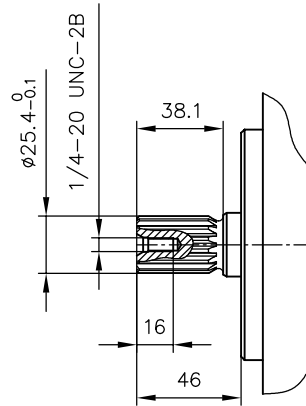

Coding 5R

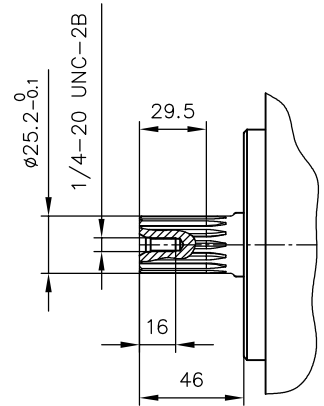

Coding 32

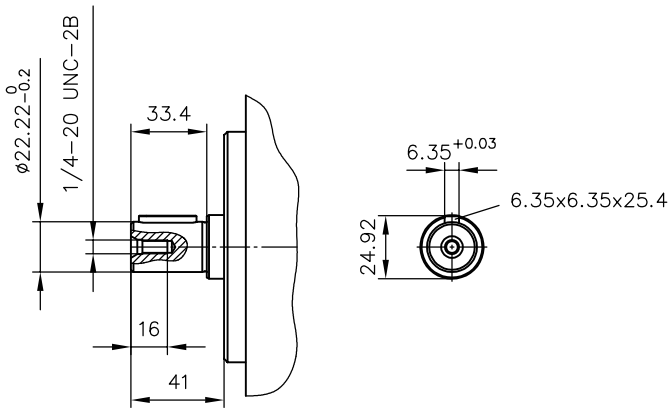

Suction and pressure connection

Suction port S

Coding ME, SE

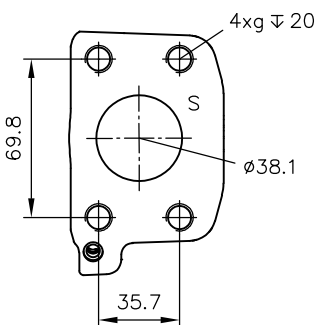

Pressure connection P

Coding MC, SC

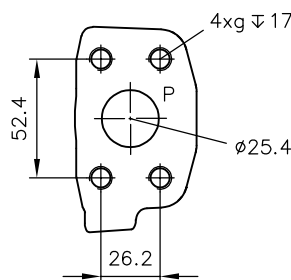

Coding	g
ME	M12
SE	1/2-13 UNC-2B

Coding	g
MC	M10
SC	3/8-16 UNC-2B

Suction and pressure connection for axial connections

Coding **OH, OF**

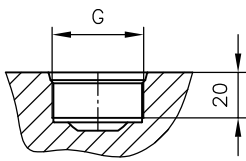

Coding	G
Suction port S	
OH	1 7/8"-12 UNF-2B
Pressure connection P	
OF	1 5/16"-12 UNF-2B

Version with radial connections with thru-shaft

Coding **AS5**

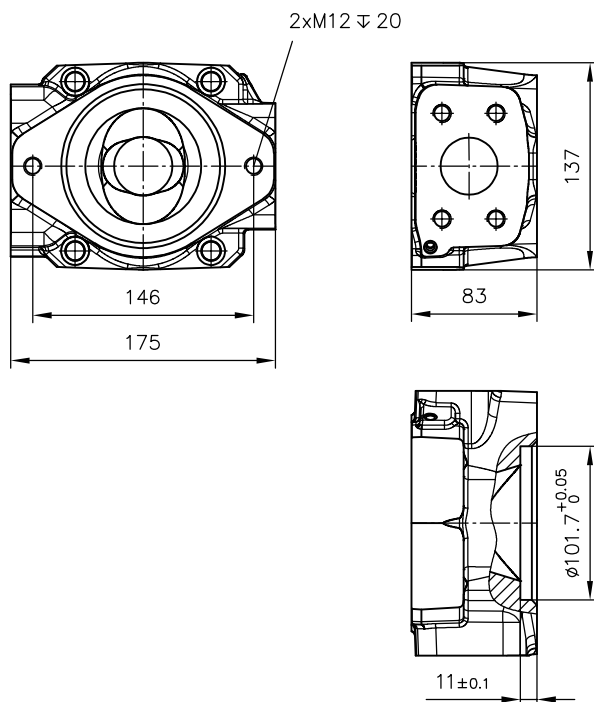

4.1.3 C41V 60.60, C41V 60.72, C41V 60.84

Version with radial connections without thru-shaft

Clockwise rotation direction
(viewed from shaft journal)

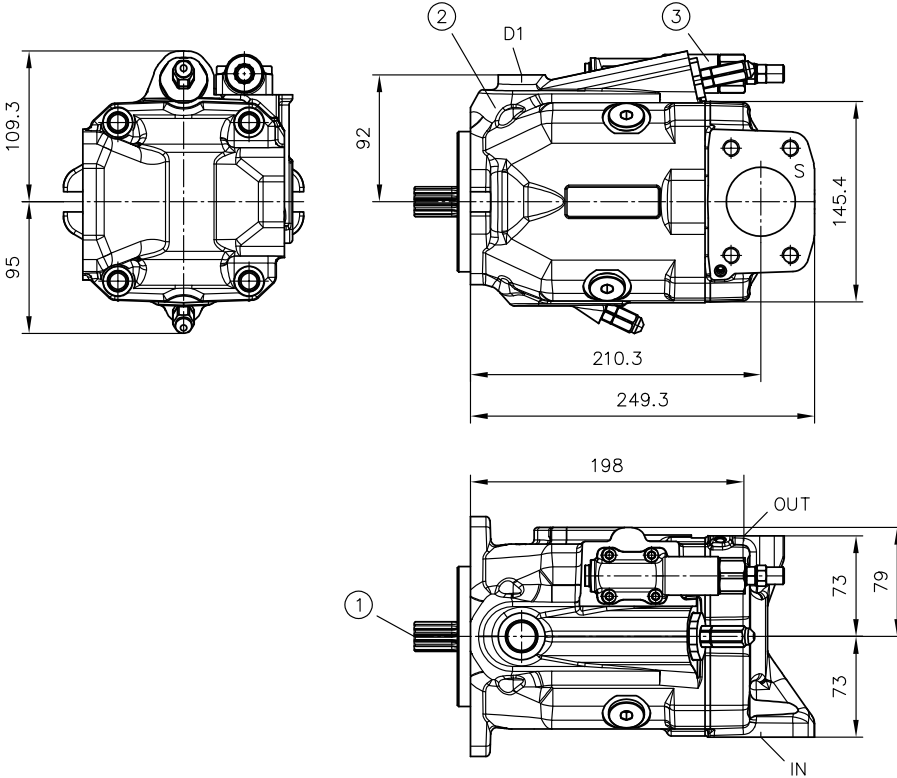

Anticlockwise rotation direction
(viewed from shaft journal)

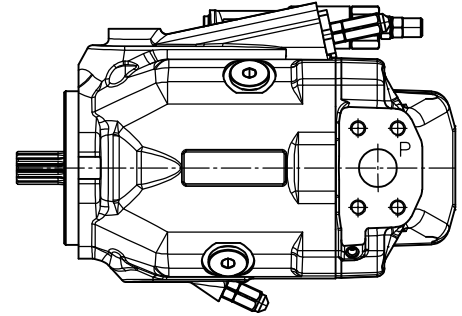

- 1 Shaft version
- 2 Flange version
- 3 Controller

Version with axial connections

Clockwise rotation direction
(viewed from shaft journal)

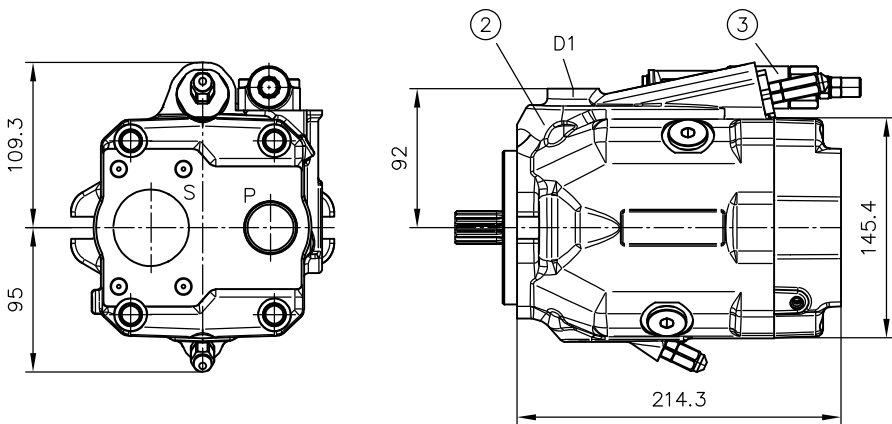

Anticlockwise rotation direction
(viewed from shaft journal)

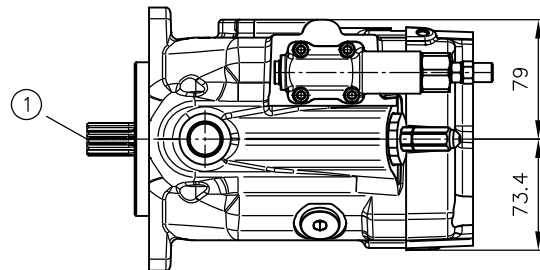
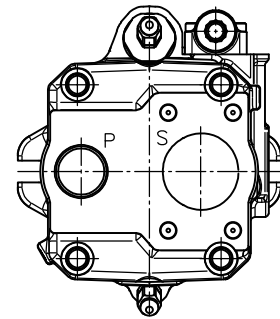

- 1 Shaft version
- 2 Flange version
- 3 Controller

Flange version

Coding S5

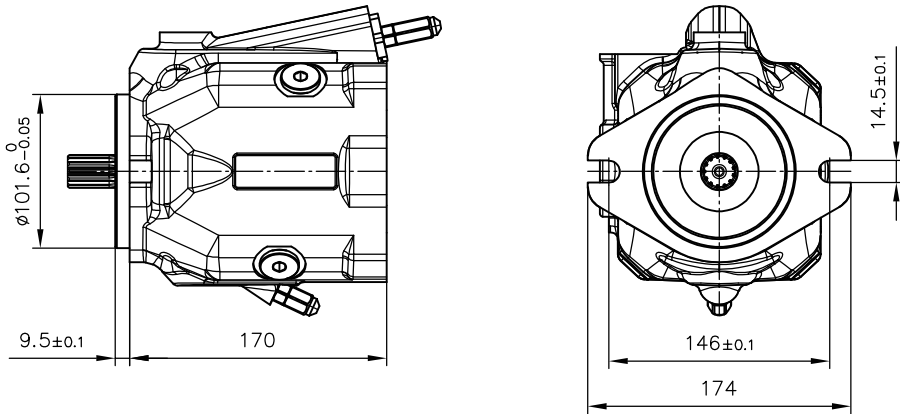

Coding S7

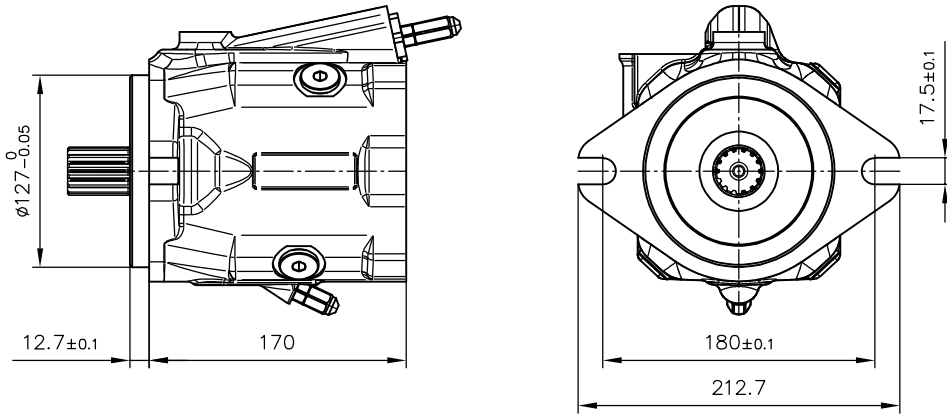

Coding S8

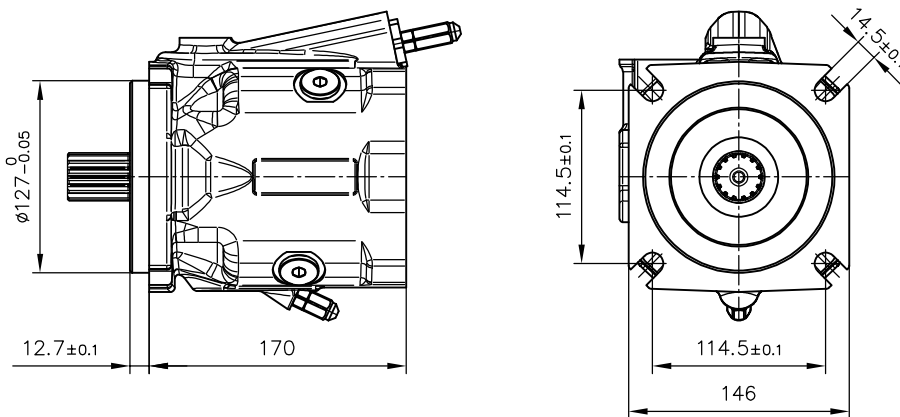

Shaft version

Coding 04

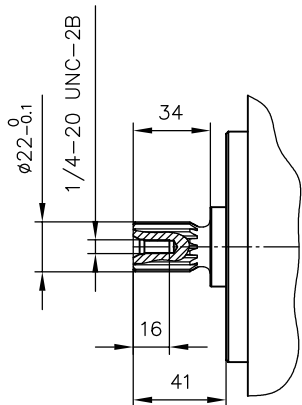

Coding 05

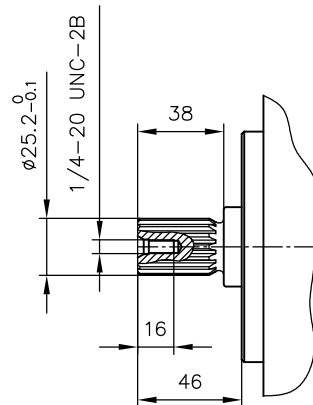

Coding 5R

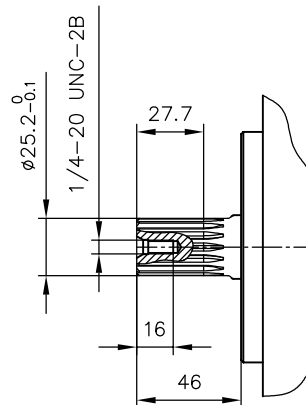

Coding 06

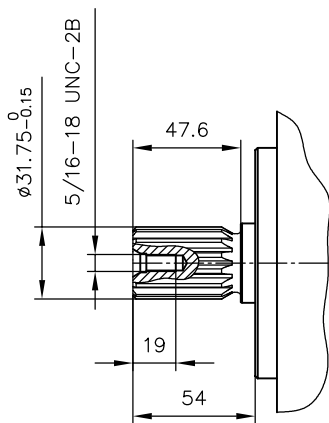

Coding 6R

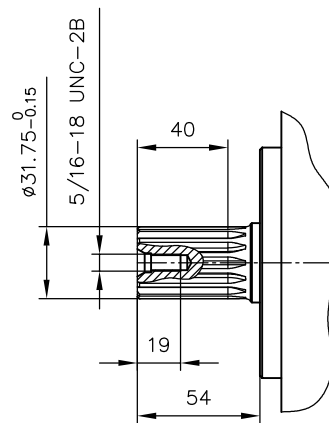

Coding 34

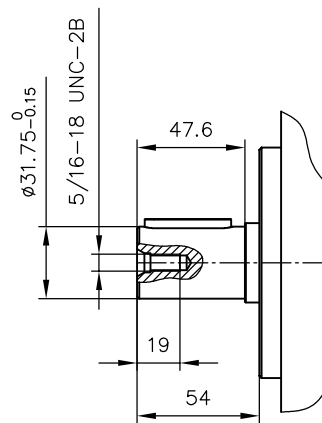

Suction and pressure connection

Suction port S

Coding MF, SF

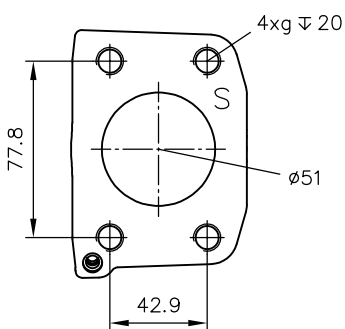

Pressure connection P

Coding MC, SC

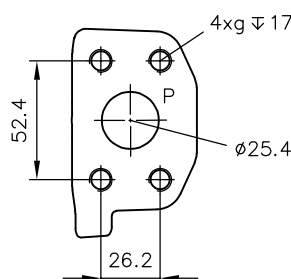

Coding	g
MF	M12
SF	1/2-13 UNC-2B

Coding	g
MC	M10
SC	3/8-16 UNC-2B

Suction and pressure connection for axial connections

Coding **MF, OF**

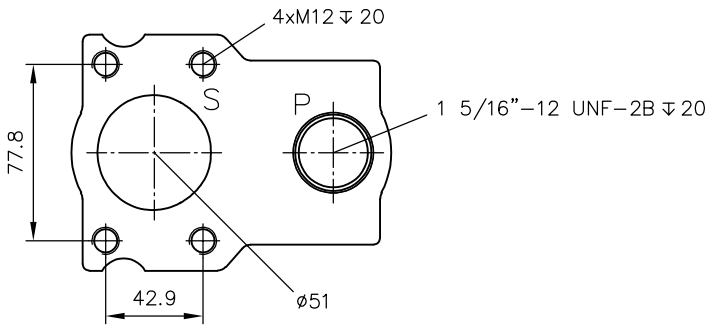

- Suction port **S** = Coding **MF**
- Pressure connection **P** = Coding **OF**

Version with radial connections with thru-shaft

Coding **AS5**

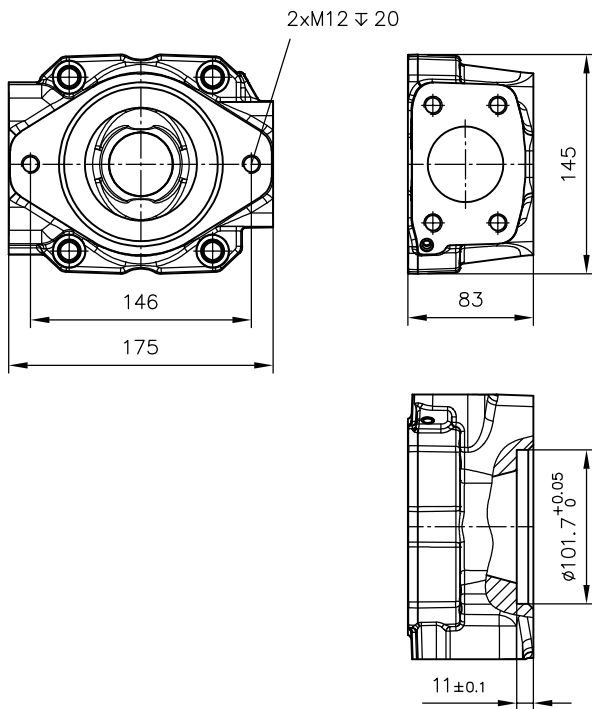

4.2 Pump controller

Coding RP0

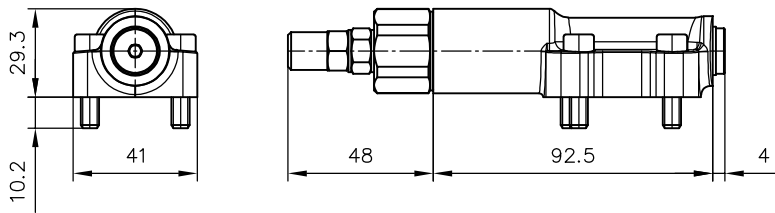

Coding RP2 and RP2-LS2

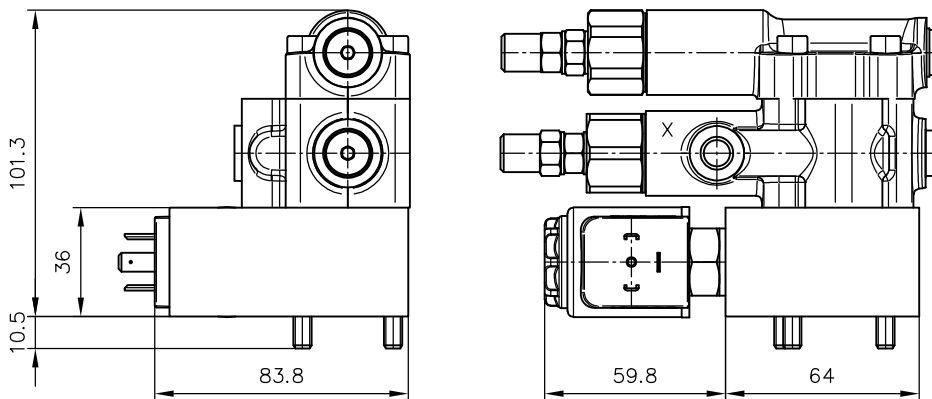

Coding LS0, LS2, LS3

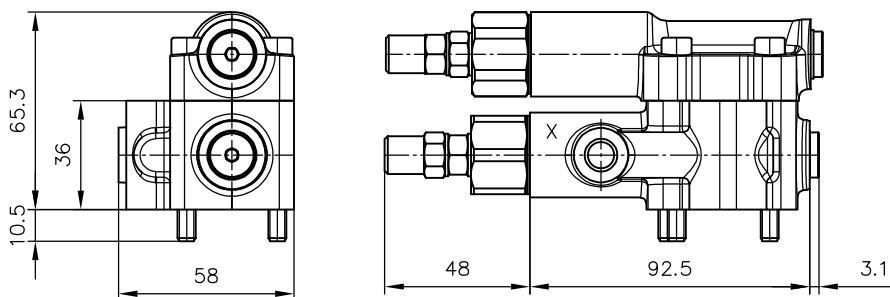

Coding PEC

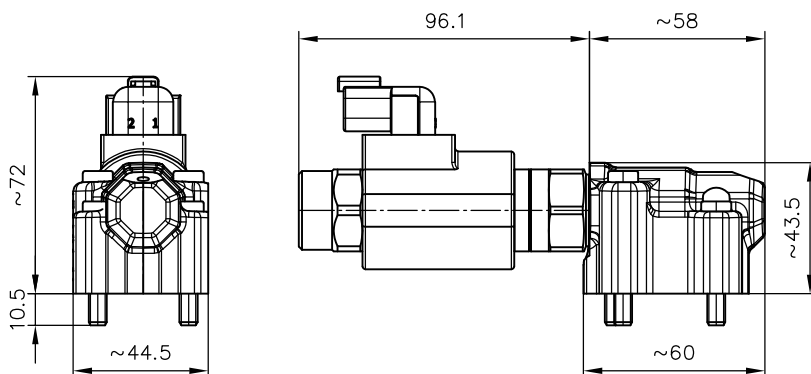

Coding **RNO and RN1**

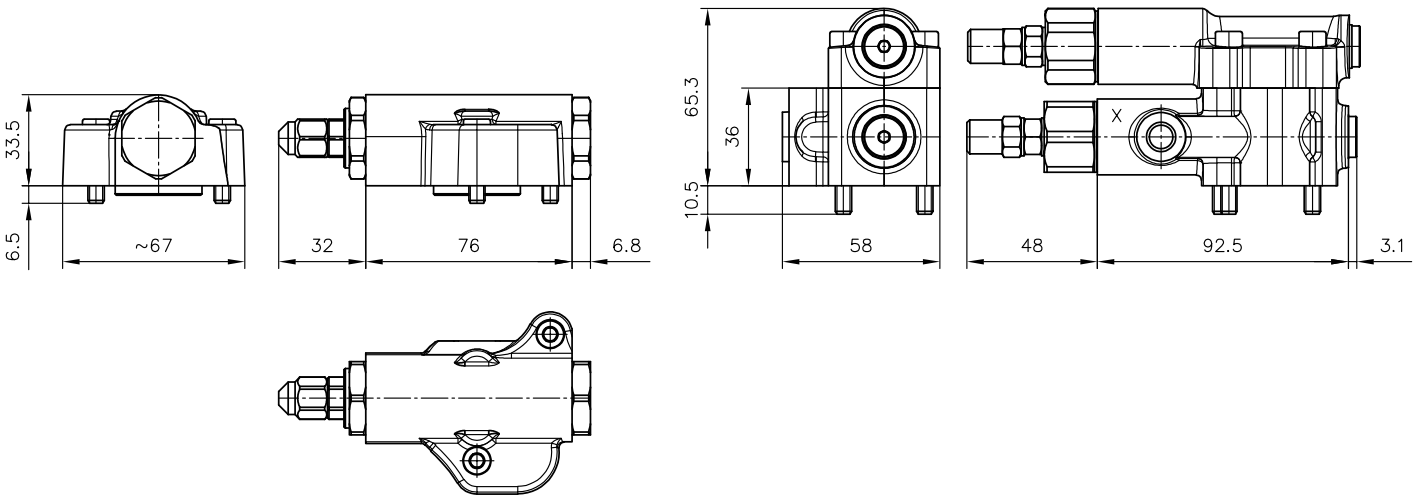

Coding **RN2-LS2 and RN2-LS0**

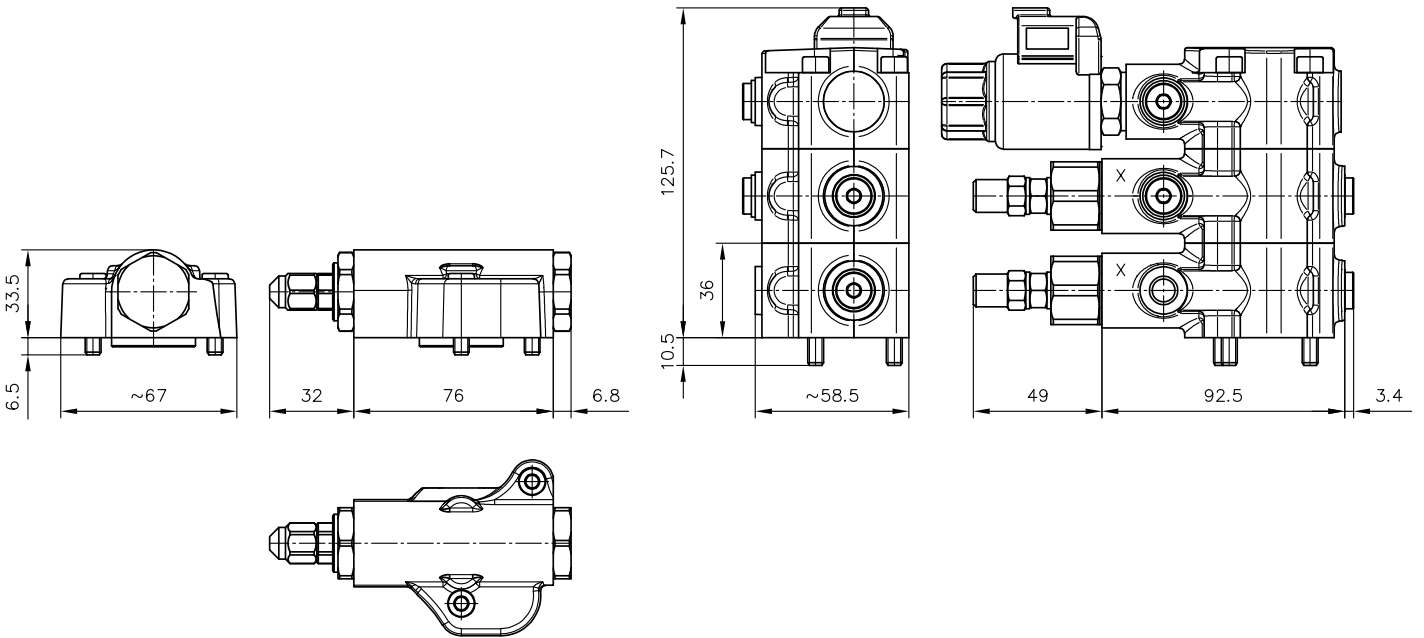

5 Installation, operation and maintenance information

Observe the document B 5488 "General operating instructions for assembly, commissioning, and maintenance."

5.1 Intended use

This product is intended exclusively for hydraulic applications (fluid technology).

The user must observe the safety measures and warnings in this document.

Essential requirements for the product to function correctly and safely:

- ▶ All information in this documentation must be observed. This applies in particular to all safety measures and warnings.
- ▶ The product must only be assembled and put into operation by specialist personnel.
- ▶ The product must only be operated within the specified technical parameters described in detail in this document.
- ▶ All components must be suitable for the operating conditions when using an assembly.
- ▶ The operating instructions for the components, assemblies and the specific complete system must also always be observed.

If the product can no longer be operated safely:

1. Remove the product from operation and mark it accordingly.
 - ✓ It is then not permitted to continue using or operating the product.

5.2 Assembly information

The product must only be installed in the complete system with standard and compliant connection components (screw fittings, hoses, pipes, fixtures etc.).

The product must be shut down correctly prior to disassembly (in particular in combination with hydraulic accumulators).



DANGER

Sudden movement of the hydraulic drives when disassembled incorrectly

Risk of serious injury or death

- ▶ Depressurise the hydraulic system.
- ▶ Perform safety measures in preparation for maintenance.

5.2.1 General information

During assembly, note the following principles:

- Only trained persons are allowed to mount or remove the pump.
- Always ensure absolute cleanliness to prevent contamination from affecting the pump.
- Remove all plastic plugs before operation.
- Avoid installation above the tank ("Installation positions").
- Observe the electric reference values.
- Before initial use, fill the pump with hydraulic fluid and bleed. Automatic pump filling via the suction line by opening the drain ports is not possible.
- Always supply the pump with hydraulic fluid from the start. Even just a short period with insufficient hydraulic fluid can damage the pump. Such damage is not immediately visible once the pump is put into operation.
- Never drain the pump.
- Hydraulic fluid which flows back into the tank must not be sucked back in immediately (install baffles!).
- Before first use, run the pump for approx. 10 minutes at max. 50 bar after initial start-up.
- Do not use the entire pressure range of the pump until it has been thoroughly bled and flushed.
- From the start, always keep the temperature within the specified range . Never exceed the maximum temperature.
- Always comply with the cleanliness level of the hydraulic fluid. In addition, filter the hydraulic fluid appropriately .

- Self-installed filters in the suction line must be approved beforehand by HAWE Hydraulik.
- A system pressure-limiting valve must be installed in the pressure line so that the maximum system pressure is not exceeded.

5.2.2 Connections

The connecting lines' nominal width depends on:

- the given usage conditions
- viscosity of the hydraulic fluid
- start-up and operating temperature
- pump speed

HAWE recommends: Use hose lines (improved damping characteristics) instead of rigid pipelines.

Pressure connection	<ul style="list-style-type: none"> ▪ The pressure connection is implemented via flange ports or threaded connections; see Chapter 4, "Dimensions" ▪ Observe the fitting manufacturers' specified tightening torques.
Suction port	<ul style="list-style-type: none"> ▪ The suction port is implemented via flange ports or threaded connections; see Chapter 4, "Dimensions". ▪ If possible, route the suction line to the tank on a rising gradient. This allows trapped air to escape. ▪ The absolute suction pressure must not fall below 0.8 bar. ▪ A hose line should generally be used in preference to a rigid pipe line.
Drain port	<ul style="list-style-type: none"> ▪ The pump features 4 drain ports, see Chapter 5.2.3, "Installation positions". The cross-section is determined by the max. permissible housing pressure. ▪ Integrate the leakage line in the system in such a way as to prevent direct connection with the suction line of the pump. ▪ All drain ports can be used simultaneously. ▪ A separate leakage line from the pump controller to the tank is not required. ▪ The top drain port can be used to fill the housing.
LS port X	<ul style="list-style-type: none"> ▪ The LS line is connected via an G 1/8 threaded connection to the X port of the controller. ▪ The nominal width of the line depends on the mounting position of the pump and should be 10% of the pressure line capacity. A hose line should generally be used in preference to a rigid pipe connection. ▪ When the proportional directional spool valve is in neutral position, the LS line must always be fully relieved (pump controller type LS2, RP2-LS2, RN0 and RN2-LS2 only)! For pump controller type LS0 and RN2-LS0, the relieving takes place internally in the pump controller.
Remote-control port X	The remote-control line is connected via a G 1/8 threaded connection to the X port of the LS3 controller.

5.2.3 Installation positions

The pump features 4 drain ports. In the delivery condition, connection D1 is open and connections D2, D3 and D4 are sealed.

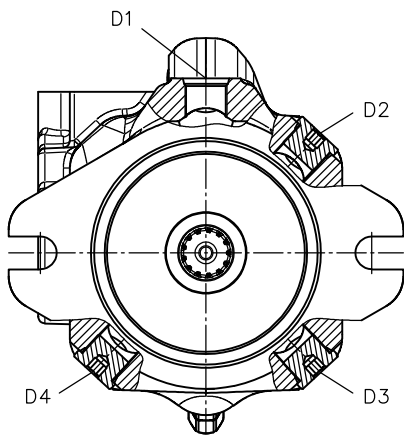

Prior to the installation in the vehicle, fill the pump with hydraulic fluid to at least three quarters of its volume in a horizontal position.

The uppermost drain port must always be used. If D1 is not the uppermost drain port, it must be sealed; to do so, remove the tapped plug from the uppermost drain port and fit it to D1 instead.

The pump can be installed above the oil level in the tank if the minimum inlet pressure at the suction port is not undershot.

If the pump is installed outside the tank, it is recommended to provide a baffle plate in the tank between the leakage line and the suction line to calm the hydraulic fluid.

Horizontal installation

Installation in the tank

Pump below the oil level

- $A \geq 200 \text{ mm}$

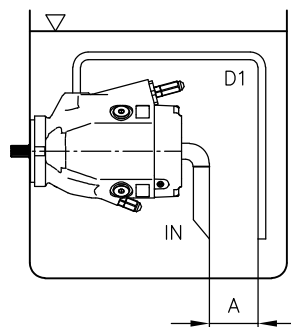

Pump above the oil level

Inlet pressure $\geq 0.8 \text{ bar abs.}$

- $B \leq 800 \text{ mm}$
- $C = 200 \text{ mm}$

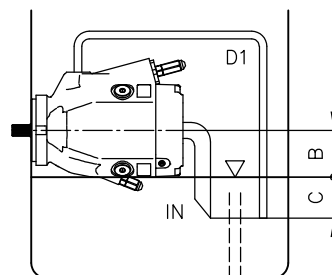

Installation outside the tank

Pump above the oil level

Inlet pressure $\geq 0.8 \text{ bar abs.}$

- $B \leq 800 \text{ mm}$
- $C = 200 \text{ mm}$

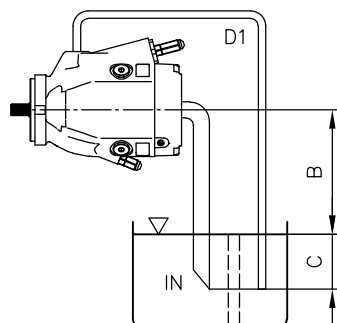

Pump below the oil level

- $C = 200 \text{ mm}$

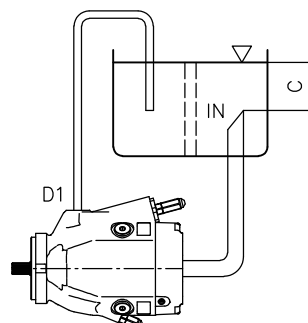

Vertical installation

Installation in the tank

Pump below the oil level

- $A \geq 200 \text{ mm}$

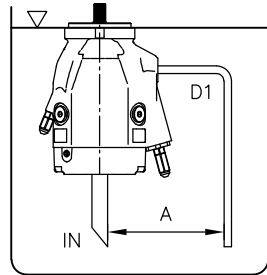

Pump above the oil level
Inlet pressure $\geq 0.8 \text{ bar abs.}$

- $B \leq 800 \text{ mm}$
- $C = 200 \text{ mm}$

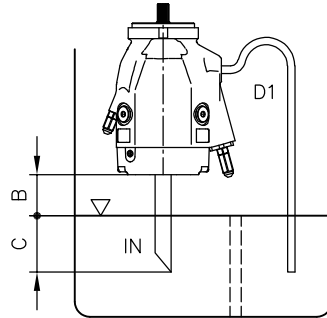

Installation outside the tank

Pump above the oil level
Inlet pressure $\geq 0.8 \text{ bar abs.}$

- $B \leq 800 \text{ mm}$
- $C = 200 \text{ mm}$

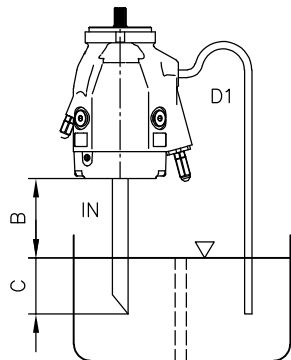

- **IN** = Suction line
- **D1** = Leakage line
- **A** = Minimum distance between suction line and leakage line
- **B + C** = Maximum suction height
- **C** = Minimum installation depth of suction line

5.3 Operating instructions

Observe product configuration and pressure/flow rate.

The statements and technical parameters in this document must be strictly observed.

The instructions for the complete technical system must also always be followed.

! NOTICE

- ▶ Read the documentation carefully before usage.
- ▶ The documentation must be accessible to the operating and maintenance staff at all times.
- ▶ Keep documentation up to date after every addition or update.

⚠ CAUTION

Overloading components due to incorrect pressure settings.

Risk of minor injury. Parts may burst or fly off, and uncontrolled leakage of hydraulic fluid.

- Pay attention to the maximum operating pressure of the pump, valves and fittings.
- Always monitor the pressure gauge when setting and changing the pressure.

Purity and filtering of the hydraulic fluid

Fine contamination can significantly impair the function of the product. Contamination can cause irreparable damage.

Examples of fine contamination include:

- Swarf
- Rubber particles from hoses and seals
- Dirt due to assembly and maintenance
- Mechanical debris
- Chemical ageing of the hydraulic fluid

! NOTICE

New hydraulic fluid from the manufacturer may not have the required purity.

Damage to the product is possible.

- ▶ Filter new hydraulic fluid to a high quality when filling.
- ▶ Do not mix hydraulic fluids. Always use hydraulic fluid that is from the same manufacturer, of the same type, and with the same viscosity properties.

For smooth operation, pay attention to the cleanliness level of the hydraulic fluid (cleanliness level see Chapter 3, "Parameters").

Additionally applicable document: [D 5488/1](#) oil recommendations

5.4 Maintenance information

This product is largely maintenance-free.

Check regularly (at least once a year) by visual inspection whether the hydraulic connections are damaged. If external leakages are found, shut down and repair the system.

Clean the surface of the device regularly (at least once a year) (dust deposits and dirt).

6 Other information

6.1 Planning information

Determination of nominal sizes

Delivery flow	$Q = \frac{V_g \cdot n \cdot \eta_V}{1000} \text{ (l/min)}$	Q = Flow rate (l/min)
Drive torque	$M = \frac{V_g \cdot \Delta p}{20 \cdot \pi \cdot \eta_{mh}} \text{ (Nm)}$	M = Torque (Nm)
Drive power	$P = \frac{2\pi \cdot M \cdot n}{60000} = \frac{Q \cdot \Delta p}{600 \cdot \eta_t} \text{ (kW)}$	P = Power (kW)
		V _g = Geom. output volume (cm ³ /rev)
		Δp = Differential pressure
		n = Speed (min ⁻¹)
		η _v = Volumetric efficiency
		η _{mh} = Mechanical-hydraulic efficiency
		η _t = Overall efficiency (η _t = η _v · η _{mh})

6.2 Pump controller - Further information

6.2.1 Pressure controller

The RP0, RP2, LS3 and PEC controllers are pressure controllers. As soon as the pump pressure exceeds the set value, the controller reduces the swivel angle of the pump and regulates a constant pressure level.

RP0: Pressure controller with fixed pressure setting. The pressure setting is implemented via an adjusting screw on the controller.

RP2: 2-stage pressure controller for electrical switching between two pressure settings. The two pressure settings are implemented via two adjustment screws on the controller. The maximum pressure is set at one of the two main stages. The second, lower pressure is set at a pilot valve, which can be switched on or off using an electrically operated 2/2-way directional valve. The 2/2-way directional valve is available as an N/C contact (closed in normal position) or as an N/O contact (open in normal position).

Additional and solenoid voltage:

Coding	Description	Nominal voltage
1	N/C contact (closed in normal position)	12 V DC
2		24 V DC
6	N/O contact (open in normal position)	12 V DC
7		24 V DC

LS3: Pressure controller with fixed pressure setting and additionally with remote-control port. The pressure setting is implemented via an adjusting screw on the controller. An external pilot valve can be connected to the remote-control port to enable remote adjustment.

PEC: Electro-proportional pressure controller with falling characteristic line. The maximum pressure is set mechanically on the pressure controller. Below this, the pressure can be adjusted electro-proportionally.

Typical application

- Hydraulic fan control
- eLS systems

Additional and solenoid voltage:

Coding	Description	Nominal voltage
1	Falling characteristic line (closed in normal position)	12 V DC
2		24 V DC

RPO

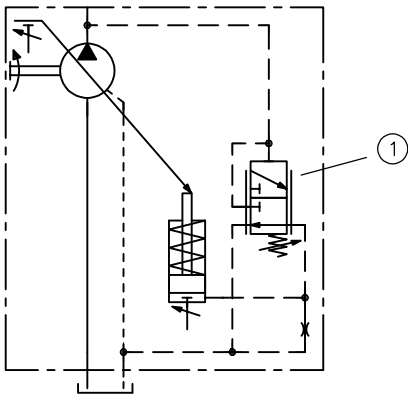

- 1 Pressure controller

RP2

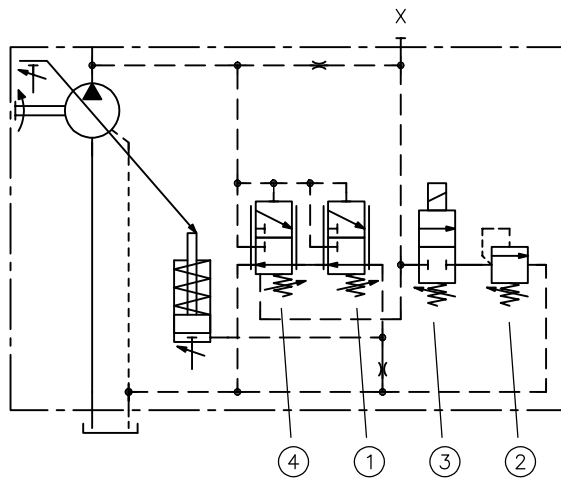

- 1 Main stage for setting the maximum pressure
2 Pilot valve for setting the second, lower pressure level
3 2/2-way directional valve for switching the pilot valve on or off
4 Main stage that regulates the second, lower pressure level in conjunction with the pilot valve

LS3

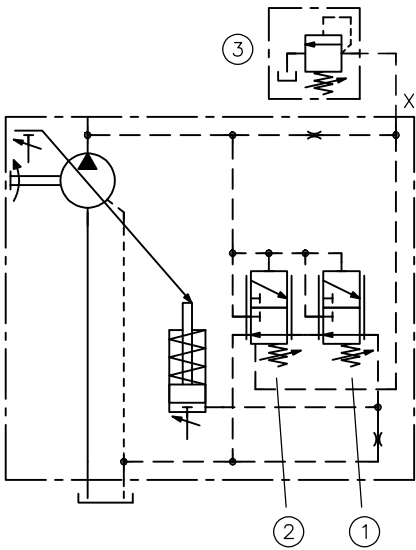

- 1 Main stage for setting the maximum pressure
2 Main stage that can regulate a lower pressure in conjunction with the pilot valve at connection X
3 Pilot valve (not included in scope of delivery)

PEC

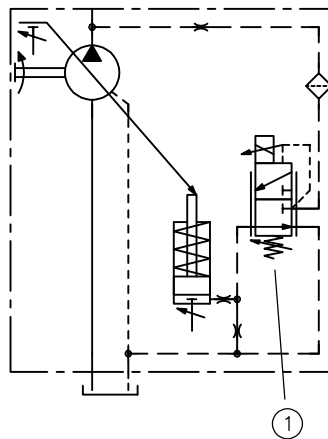

- 1 Electro-proportional pressure controller with falling characteristic line

Characteristic lines

RP0, RP2, LS3

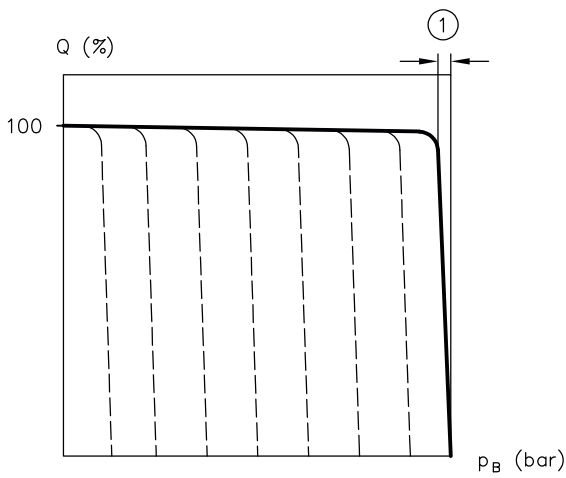

p_B operating pressure (bar); Q delivery flow (%)

1 Approx. 4 bar

PEC

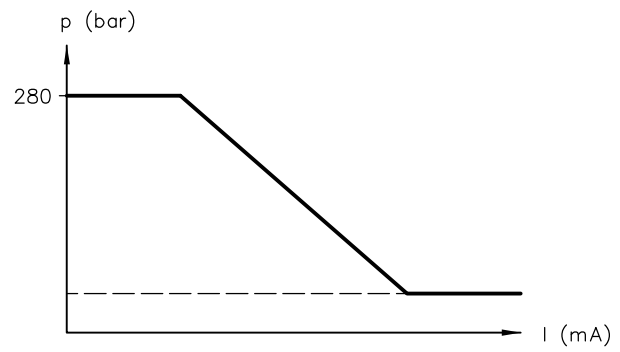

I current (mA); p pressure (bar)

RP0

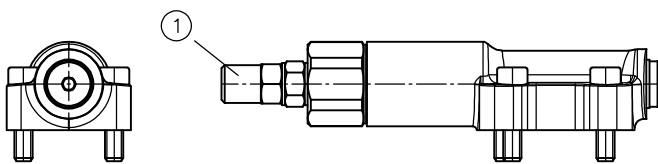

1 Maximum pressure p_{max}

RP2

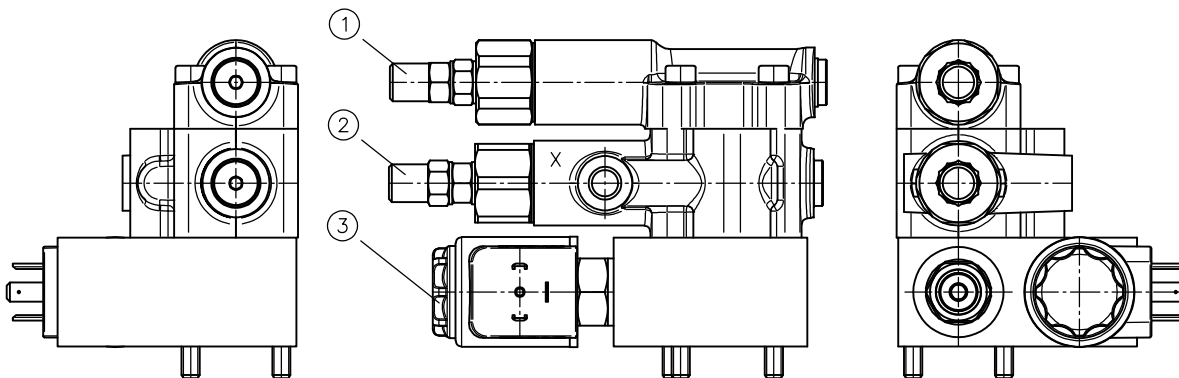

1 Maximum pressure p_{max}

2 Differential pressure Δp (main stage that regulates the second, lower pressure level in conjunction with the pilot valve)

3 Pilot pressure p_{pil}

LS3

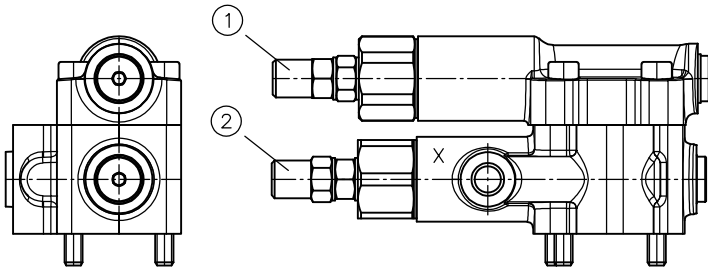

- 1 Maximum pressure p_{max}
 2 Differential pressure Δp (main stage that can regulate a lower pressure in conjunction with the pilot valve at connection X)

PEC

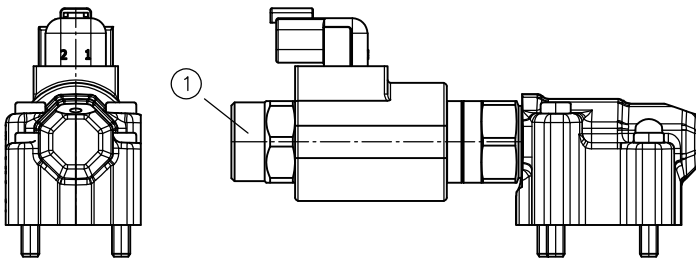

- 1 Maximum pressure p_{max}

Pressure adjustment	Pressure range (bar)	Factory-set pressure setting (bar)
Maximum pressure p_{max} (RP0, RP2, LS3)	80 ... 250 or 280	250 or 280
Differential pressure Δp (RP2, LS3)	12 ... 40	19

⚠ CAUTION

Overloading components due to incorrect pressure settings.

Risk of minor injury. Parts may burst or fly off, and uncontrolled leakage of hydraulic fluid.

- Pay attention to the maximum operating pressure of the pump, valves and fittings.
- Always monitor the pressure gauge when setting and changing the pressure.

6.2.2 Load-sensing controller

The LS2, LS0 and RP2-LS2 controllers are flow controllers that generate a variable, speed-independent flow rate. They adapt the displacement volume of the pump to the required flow rate of the consumer and regulate a constant difference between load pressure and pump pressure.

The integrated pressure limitation restricts the maximum pressure to a set value.

LS2:

- Connection X-T sealed
- Version for combination with hydraulic valves that relieve the LS signal in the valve, for example, type PSV proportional directional spool valve

LS0:

- Connection X-T open
- Only for use with hydraulic valves without their own relief of the LS signal

RP2-LS2:

- Combination of flow controller (LS2) and 2-stage pressure controller (RP2)
- Connection X-T sealed
- Version for combination with hydraulic valves that relieve the LS signal in the valve, for example, type PSV proportional directional spool valve
- With integrated electrical switching between two different setting values for the pressure limitation. The two pressure settings are implemented via two adjustment screws on the controller. The maximum pressure is set at one of the two main stages. The second, lower pressure is set at a pilot valve, which can be switched on or off using an electrically operated 2/2-way directional valve. The 2/2-way directional valve is available as an N/C contact (closed in normal position) or as an N/O contact (open in normal position).

Additional and solenoid voltage:

Coding	Description	Nominal voltage
1	N/C contact (closed in normal position)	12 V DC
2		24 V DC
6	N/O contact (open in normal position)	12 V DC
7		24 V DC

LS2

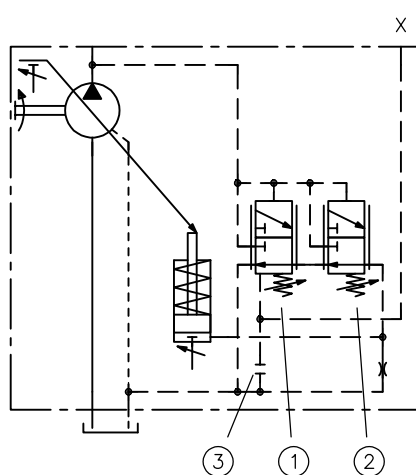

LS0

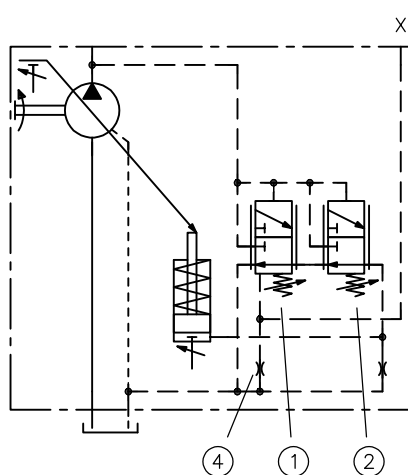

- 1 LS controller: Regulates a constant difference between load pressure and pump pressure
- 2 Pressure limitation: Limits the pump pressure to a maximum value
- 3 Connection X-T sealed
- 4 Connection X-T open for the internal relief of the LS signal

RP2-LS2

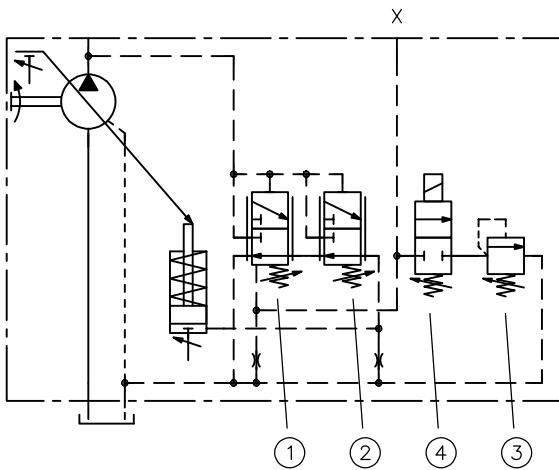

- 1 LS controller: Regulates a constant difference between load pressure and pump pressure
- 2 Pressure limitation: Limits the pump pressure to a maximum value
- 3 Pilot valve for setting the second, lower pressure level
- 4 2/2-way directional valve for switching the pilot valve on or off

LS0, LS2

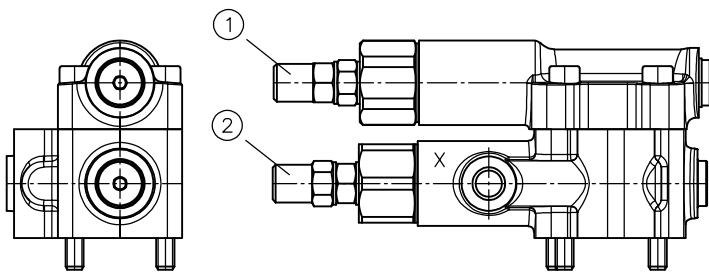

- 1 Maximum pressure p_{max}
- 2 Differential pressure Δp (stand-by pressure)

RP2-LS2

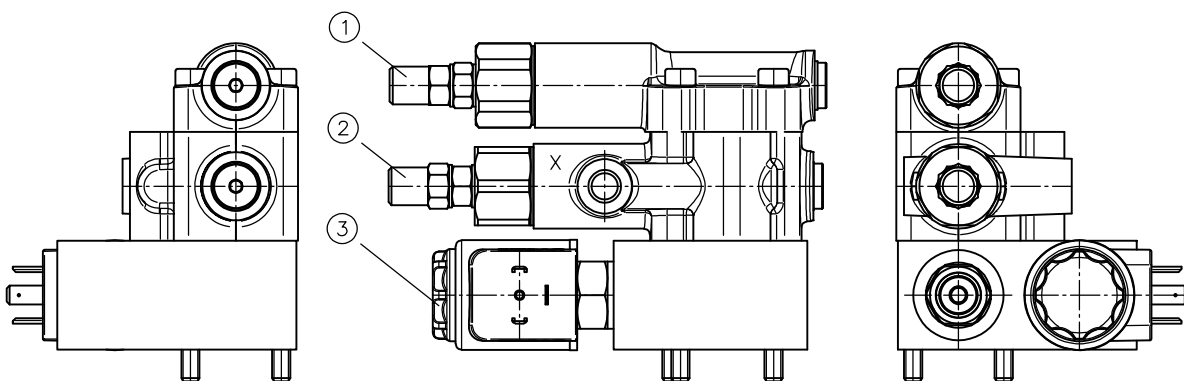

- 1 Maximum pressure p_{max}
- 2 Differential pressure Δp (stand-by pressure)
- 3 LS pressure limitation p_{LS}

Pressure adjustment	Pressure range (bar)	Factory-set pressure setting (bar)
Maximum pressure p_{\max}	80 ... 250 or 280	250 or 280
Differential pressure Δp	12 ... 40	19

 **CAUTION****Overloading components due to incorrect pressure settings.**

Risk of minor injury. Parts may burst or fly off, and uncontrolled leakage of hydraulic fluid.

- Pay attention to the maximum operating pressure of the pump, valves and fittings.
- Always monitor the pressure gauge when setting and changing the pressure.

6.2.3 Power controller

RN0, RN1

The RN0 and RN1 controllers are power controllers with fixed settings. When the product of displacement volume times pressure exceeds the set value, the controller reduces the pump's swivel angle. This protects the drive shaft, motor or gearbox from overloading ($p_B \times V_g = \text{constant}$).

RN0: Combination of power controller and load-sensing controller with integrated pressure limitation without LS relief

RN1: Combination of power controller and mechanically adjustable pressure controller

RN2-LS2, RN2-LS0

The RN2-LS2 and RN2-LS0 controllers are 2-stage power controllers with electrical switching between two fixed setting values. The 2/2-way directional valve for switching between the two power levels is available as an N/C contact (closed in normal position) or as an N/O contact (open in normal position).

Typical applications

- Backhoe loaders in which the entire motor power is used for the working hydraulics during excavation operation – whereas in wheel loader operation, the power is divided between the working functions and the travel drive.
- Motor-pump units (MPUs) for electrified mobile work machines in which the electric motor is briefly over-currented to cover power peaks.

RN2-LS2: Combination of power controller with electrical switching between two torque settings and load-sensing controller with pressure limitation without LS relief

RN2-LS0: Combination of power controller with electrical switching between two torque settings and load-sensing controller with pressure limitation with LS relief

Additional and solenoid voltage:

Coding	Description	Nominal voltage
1	N/C contact (closed in normal position)	12 V DC
2		24 V DC
6	N/O contact (open in normal position)	12 V DC
7		24 V DC

Setting

The setting is made either as a torque limitation (Nm) or power limitation (kW) at the corresponding speed (min^{-1}).

Drive torque

$$M = \frac{V_g \cdot \Delta p}{20 \cdot \pi \cdot \eta_{mh}} (\text{Nm})$$

V_g = Geometric output volume (cm^3/rev)

Δp = Differential pressure

Drive power

$$P = \frac{2\pi \cdot M \cdot n}{60000} = \frac{Q \cdot \Delta p}{600 \cdot \eta_t} (\text{kW})$$

n = Speed (min^{-1})

η_v = Volumetric efficiency

η_{mh} = Mechanical-hydraulic efficiency

η_T = Overall efficiency $\eta_T = \eta_v \cdot \eta_{mh}$

Q = Flow rate (l/min)

M = Torque (Nm)

P = Power (kW)

RN0

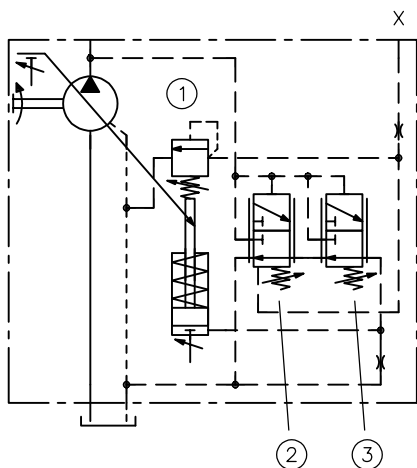

RN1

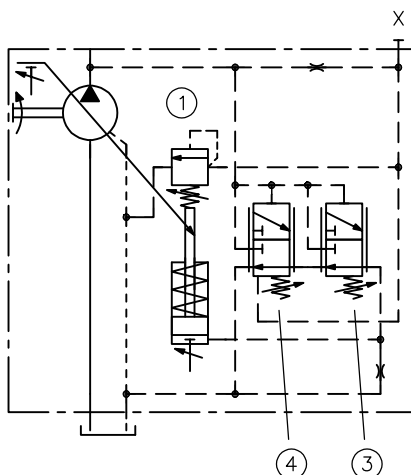

- 1 Power controller: Limits the torque of the pump to a set maximum value. Works as a pilot valve of the LS controller (2) or the main stage (4)
- 2 LS controller: Regulates a constant difference between load pressure and pump pressure
- 3 Pressure limitation: Limits the pump pressure to a maximum value
- 4 Main stage for the power controller (1)

RN2-LS2

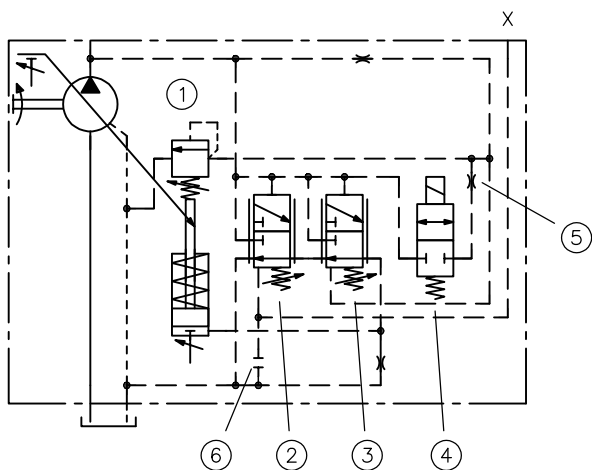

RN2-LS0

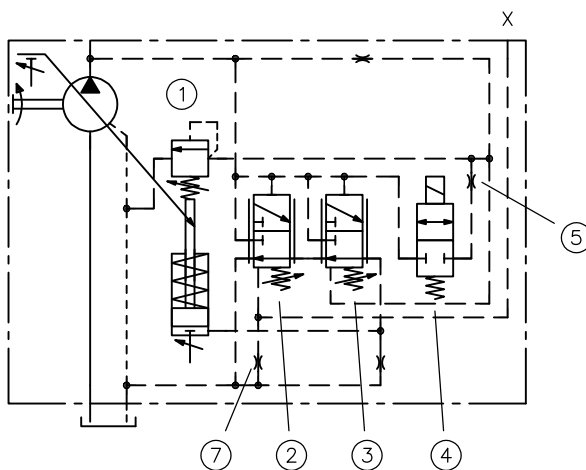

- 1 Power controller: Limits the torque of the pump to a set maximum value. Works as a pilot valve of the main stage (3). The lower characteristic line of the 2-stage power controller is set here.
- 2 LS controller: Regulates a constant difference between load pressure and pump pressure
- 3 Main stage for the power controller (1)
- 4 Electrically actuated 2/2-way directional valve for switching between two torque settings
- 5 Orifice for setting the upper characteristic line of the 2-stage power controller. The larger the orifice diameter, the higher the pressure on the spring side of the main stage (3) and therefore the distance between the lower and upper characteristic line of the 2-stage power controller.
- 6 Connection X-T sealed
- 7 Connection X-T open for the internal relief of the LS signal

Characteristic lines

RN0, RN1

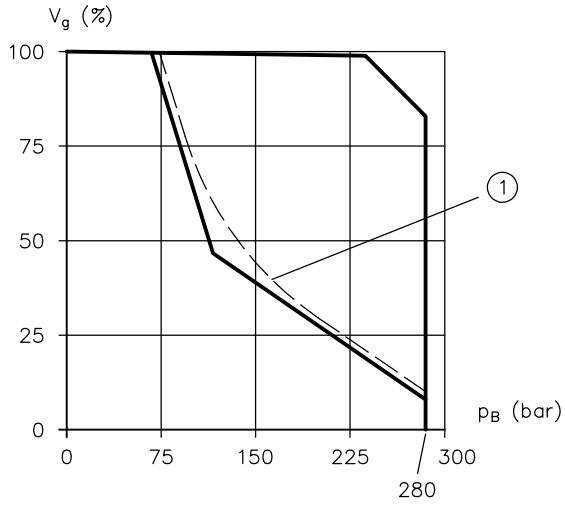

p_B pressure (bar); V_g displacement volume (%)

1 Theoretical torque

RN2-LS2, RN2-LS0

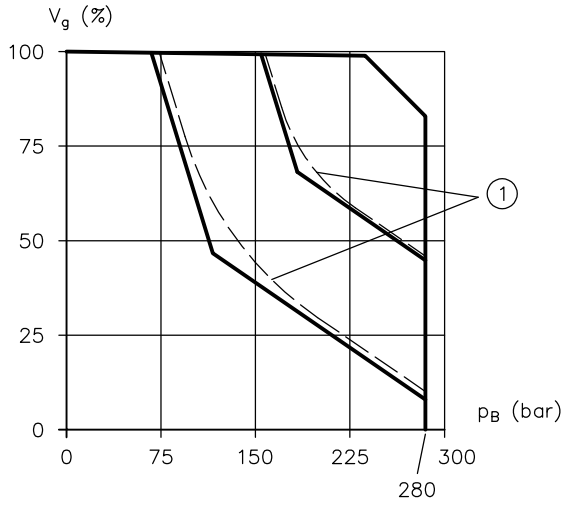

p_B pressure (bar); V_g displacement volume (%)

1 Theoretical torque

RN0, RN1

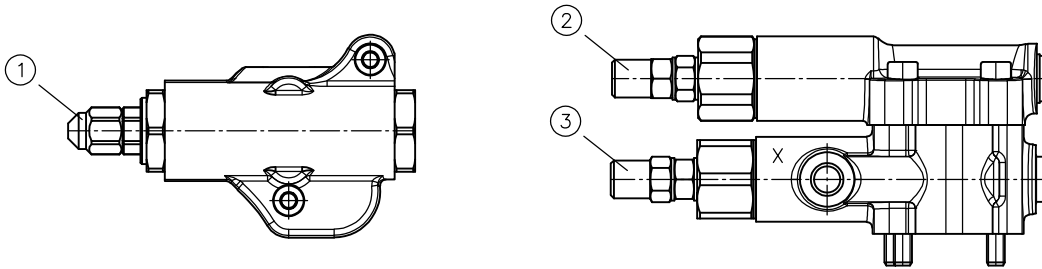

- 1 Torque setting M_{max}
- 2 Maximum pressure p_{max}
- 3 Differential pressure Δp (standby pressure) at RN0 or main stage for the power controller at RN1

RN2-LS2, RN2-LS0

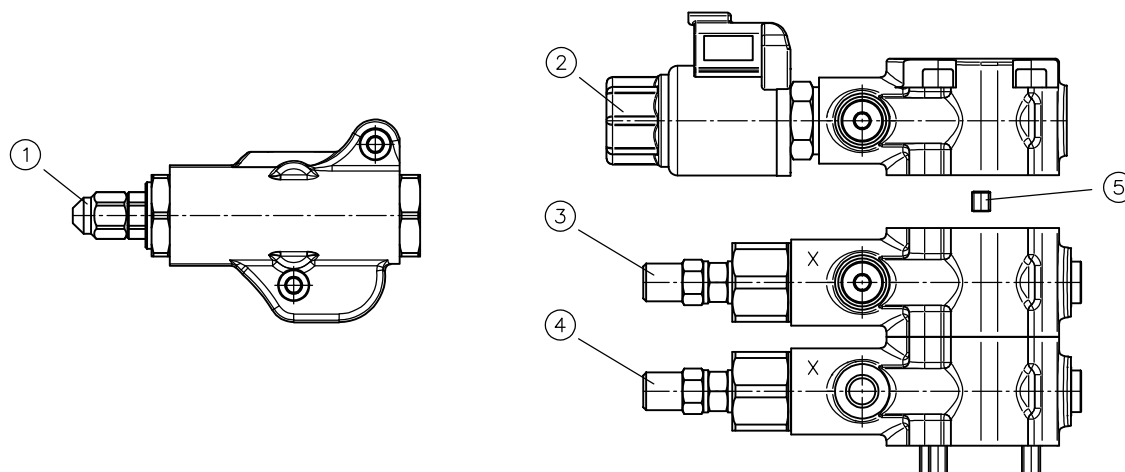

- 1 Pilot valve of the power controller for setting the upper characteristic line of the 2-stage power controller
- 2 2/2-way directional valve
- 3 Main stage of the power controller
- 4 Differential pressure Δp (stand-by pressure)
- 5 Orifice for setting the upper characteristic line of the 2-stage power controller

Torque setting	Min. setting value (Nm)
C41V 30..	45
C41V 48..	61
C41V 60..	97

Pressure adjustment	Pressure range (bar)	Factory-set pressure setting (bar)
Maximum pressure p_{\max}	80 ... 250 or 280	250 or 280
Differential pressure Δp	12 ... 40	19

CAUTION

Overloading components due to incorrect pressure settings.

Risk of minor injury. Parts may burst or fly off, and uncontrolled leakage of hydraulic fluid.

- Pay attention to the maximum operating pressure of the pump, valves and fittings.
- Always monitor the pressure gauge when setting and changing the pressure.

References

Additional versions

- Variable displacement axial piston pump type V60N: D 7960 N
- Variable displacement axial piston pump type V30E: D 7960 E
- Variable displacement axial piston pump type V30D: D 7960
- Fixed displacement axial piston pump type K60N: D 7960 K
- Axial piston motors type M60N: D 7960 M
- Proportional directional spool valve type EDL: D 8086
- Proportional directional spool valves types PSL, PSV size 2: D 7700-2
- Proportional directional spool valves types PSL/PSV/PSM, size 3: D 7700-3
- Proportional directional spool valve, type PSL, PSM and PSV size 5: D 7700-5
- Proportional directional spool valve type PSLF, PSVF and SLF size 3: D 7700-3F
- Proportional directional spool valve type PSLF, PSVF and SLF size 5: D 7700-5F
- Proportional directional spool valve banks type PSLF and PSVF size 7: D 7700-7F
- Directional spool valve banks type CWS: D 7951 CWS
- Directional spool valve type CWL: D 7953 CWL
- Load-holding valve type CLHV: D 7918-VI-C
- Load-holding valve type CLHV: D 7918-VI-PIB
- Load-holding valve type LHDV: D 7770
- Proportional amplifier type EV1M3: D 7831/2
- Proportional amplifier type EV1D: D 7831 D
- Proportional amplifier type EV2S: D 7818/1

Operating instructions

- General operating manual for the assembly, initial operation and maintenance of hydraulic components and systems: B 5488